



PRELIMINARY

## Endeavor™ Line Achiever® Series iM Air Conditioners



### **RA13NZ**

Cooling Efficiency: 13.4 SEER2/9.0 EER2

Nominal Sizes: 1.5 to 5 Ton [5.3 to 17.6 kW]

Cooling Capacities: 17.1 to 55.5 kBTU [5.0 to 16.3 kW]

## Table of Contents

Features & Benefits .....	3
Model Number Identification .....	4
General Data/Electrical Data .....	5
Accessories .....	6
Weighted Sound Power .....	6
Unit Dimensions .....	7
Clearances .....	8
Control Wiring .....	9
Application Guidelines.....	9
Refrigerant Line Size Information .....	10-13
Performance Data .....	14
Limited Warranty .....	16

## Features and Benefits

- **7 mm Condenser Copper Coil:** Requires less refrigerant allowing for a smaller and lighter footprint while enhancing reliability
- **PlusOne® Expanded Value Space:** 3 in. – 4 in. – 5 in. service valve space—provides a minimum working area of 27-square inches for easier access
- **PlusOne® Triple Service Access:** 15 in. wide, industry leading corner service access, two fastener, removeable corner and individual louver panels - makes repairs easier and faster

# Air Conditioners

<u>R</u>	<u>A</u>	<u>13</u>	<u>N</u>	<u>Z</u>	<u>24</u>	<u>A</u>	<u>J</u>	<u>1</u>	<u>N</u>	<u>A</u>	<u>LHP</u>
Brand	Product Category	SEER2	Region	Refrigerant	Capacity BTU/HR	Major Series	Voltage	Type	Controls	Minor Series	Option Code
Ruud	A - Air Conditioners	13 - 13.4 SEER2	N - North	Z - R-410A	18 - 18,000 [5.28 kW] 24 - 24,000 [7.03 kW] 30 - 30,000 [8.79 kW] 36 - 36,000 [10.55 kW] 42 - 42,000 [12.31 kW] 48 - 48,000 [14.07 kW] 60 - 60,000 [17.58 kW]	A - 1st Design	J - 1ph, 208-230/60	1 - Single Stage	N - Non-Communicating	A - 1st Design	LHP - W/HLPC

[ ] Designates Metric Conversions

AVAILABLE MODELS	Description
RA13NZ18AJ1NA	Endeavor™ Line Achiever® Series 1 1/2 ton 13.4 SEER2 Single-Stage iM Air Conditioner-208/230/1/60
RA13NZ18AJ1NALHP	Endeavor™ Line Achiever® Series 1 1/2 ton 13.4 SEER2 Single-Stage iM Air Conditioner w/ High/Low Pressure-208/230/1/60
RA13NZ24AJ1NA	Endeavor™ Line Achiever® Series 2 ton 13.4 SEER2 Single-Stage iM Air Conditioner-208/230/1/60
RA13NZ24AJ1NALHP	Endeavor™ Line Achiever® Series 2 ton 13.4 SEER2 Single-Stage iM Air Conditioner w/ High/Low Pressure-208/230/1/60
RA13NZ30AJ1NA	Endeavor™ Line Achiever® Series 2 1/2 ton 13.4 SEER2 Single-Stage iM Air Conditioner-208/230/1/60
RA13NZ30AJ1NALHP	Endeavor™ Line Achiever® Series 2 1/2 ton 13.4 SEER2 Single-Stage iM Air Conditioner w/ High/Low Pressure-208/230/1/60
RA13NZ36AJ1NA	Endeavor™ Line Achiever® Series 3 ton 13.4 SEER2 Single-Stage iM Air Conditioner-208/230/1/60
RA13NZ36AJ1NALHP	Endeavor™ Line Achiever® Series 3 ton 13.4 SEER2 Single-Stage iM Air Conditioner w/ High/Low Pressure-208/230/1/60
RA13NZ42AJ1NA	Endeavor™ Line Achiever® Series 3 1/2 ton 13.4 SEER2 Single-Stage iM Air Conditioner-208/230/1/60
RA13NZ42AJ1NALHP	Endeavor™ Line Achiever® Series 3 1/2 ton 13.4 SEER2 Single-Stage iM Air Conditioner w/ High/Low Pressure-208/230/1/60
RA13NZ48AJ1NA	Endeavor™ Line Achiever® Series 4 ton 13.4 SEER2 Single-Stage iM Air Conditioner-208/230/1/60
RA13NZ48AJ1NALHP	Endeavor™ Line Achiever® Series 4 ton 13.4 SEER2 Single-Stage iM Air Conditioner w/ High/Low Pressure-208/230/1/60
RA13NZ60AJ1NA	Endeavor™ Line Achiever® Series 5 ton 13.4 SEER2 Single-Stage iM Air Conditioner-208/230/1/60
RA13NZ60AJ1NALHP	Endeavor™ Line Achiever® Series 5 ton 13.4 SEER2 Single-Stage iM Air Conditioner w/ High/Low Pressure-208/230/1/60

STANDARD EQUIPMENT
R-410A Refrigerant
Maximum 13.4 SEER2
Maximum 9.0 EER2
Scroll Compressor
Field Installed Filter Drier
Front Seating Service Valves
Internal Pressure Relief Valve
Internal Thermal Overload
Long Line capability
Low Ambient capability with Kit
3-4-5 Expanded Valve Space
Composite Basepan
2 Screw Control Box Access
15" Access to Internal Components
Quick release louver panel design
No fasteners to remove along bottom
Optimized Venturi Airflow
Single row condenser coil
Powder coated paint
Rust resistant screws
QR code
External gauge ports
Service trays

<b>General Data</b>							
Model No.	RA13NZ18	RA13NZ24	RA13NZ30	RA13NZ36	RA13NZ42	RA13NZ48	RA13NZ60
Nominal Tonnage	1.5	2	2.5	3	3.5	4	5
<b>Valve Connections</b>							
Liquid Line O.D. – in.	3/8	3/8	3/8	3/8	3/8	3/8	3/8
Suction Line O.D. – in.	3/4	3/4	3/4	3/4	7/8	7/8	7/8
Refrigerant (R410A) furnished oz. <sup>1</sup>	70	78	86	100	126	121	186
Compressor Type	Scroll						
<b>Outdoor Coil</b>							
Net face area – Outer Coil	10.9	13.3	13.3	19.5	14.3	23.5	28.4
Net face area – Inner Coil	—	—	—	—	13.9	—	—
Tube diameter – in.	0.276	0.276	0.276	0.276	0.276	0.276	3/8
Number of rows	1	1	1	1	2	1	1
Fins per inch	24	24	24	24	24	24	22
<b>Outdoor Fan</b>							
Diameter – in.	20	24	24	24	24	26	26
Number of blades	2	3	3	3	2	3	3
Motor hp	1/7	1/6	1/6	1/6	1/5	1/5	1/5
CFM	1765	TO COME		3738	2830	4095	4186
RPM	1075	825	825	825	825	850	850
watts	154	TO COME		193	145	203	204
Shipping weight – lbs.	TO COME						
Operating weight – lbs.	TO COME						

<b>Electrical Data</b>							
Line Voltage Data (Volts-Phase-Hz)	208/230-1-60	208/230-1-60	208/230-1-60	208/230-1-60	208/230-1-60	208/230-1-60	208/230-1-60
Maximum overcurrent protection (amps) <sup>2</sup>	20	25	30	35	40	50	50
Minimum circuit ampacity <sup>3</sup>	12	16	19	21	25	33	34
<b>Compressor</b>							
Rated load amps	9	12	14	16	19	25	26
Locked rotor amps	43	60	68	92	110	120	150
<b>Condenser Fan Motor</b>							
Full load amps	0.8	0.8	0.8	0.8	0.8	1	1
Locked rotor amps	1.5	1.5	1.5	1.7	1.5	2.4	2.4

<sup>1</sup>Refrigerant charge sufficient for 15 ft. length of refrigerant lines. For longer line set requirements see the installation instructions for information about set length and additional refrigerant charge required.

<sup>2</sup>HACR type circuit breaker or fuse.

<sup>3</sup>Refer to National Electrical Code manual to determine wire, fuse and disconnect size requirements.

## Accessories

Model No.		RA13NZ18	RA13NZ24	RA13NZ30	RA13NZ36	RA13NZ42	RA13NZ48	RA13NZ60
Compressor crankcase heater*		44-17402-44	44-17402-44	44-17402-44	44-17402-44	44-17402-45	44-17402-45	44-17402-45
Low ambient control		RXAD-A08	RXAD-A08	RXAD-A08	RXAD-A08	RXAD-A08	RXAD-A08	RXAD-A08
Compressor sound cover		68-23427-26	68-23427-26	68-23427-26	68-23427-26	68-23427-25	68-23427-25	68-23427-25
Compressor hard start kit		SK-A1	SK-A1	SK-A1	SK-A1	SK-A1	SK-A1	SK-A1
Compressor time delay		RXMD-B01	RXMD-B01	RXMD-B01	RXMD-B01	RXMD-B01	RXMD-B01	RXMD-B01
Low pressure control		RXAC-A07	RXAC-A07	RXAC-A07	RXAC-A07	RXAC-A07	RXAC-A07	RXAC-A07
High pressure control		RXAB-A07	RXAB-A07	RXAB-A07	RXAB-A07	RXAB-A07	RXAB-A07	RXAB-A07
Liquid Line Solenoid (24 VAC, 50/60 Hz)	Solenoid Valve	200RD2T3TVLC	200RD2T3TVLC	200RD2T3TVLC	200RD2T3TVLC	200RD2T3TVLC	200RD2T3TVLC	200RD2T3TVLC
	Solenoid Coil	61-AMG24V	61-AMG24V	61-AMG24V	61-AMG24V	61-AMG24V	61-AMG24V	61-AMG24V
Liquid Line Solenoid (120/240 VAC, 50/60 Hz)	Solenoid Valve	200RD2T3TVLC	200RD2T3TVLC	200RD2T3TVLC	200RD2T3TVLC	200RD2T3TVLC	200RD2T3TVLC	200RD2T3TVLC
	Solenoid Coil	61-AMG120/240V	61-AMG120/240V	61-AMG120/240V	61-AMG120/240V	61-AMG120/240V	61-AMG120/240V	61-AMG120/240V
Classic Top Cap w/Label		91-101123-21	91-101123-21	91-101123-21	91-101123-21	91-101123-21	91-101123-21	91-101123-21

\*Crankcase Heater recommended with Low Ambient Kit.

## Weighted Sound Power Level (dBA)

Unit Size - Voltage Series	Standard	TYPICAL OCTAVE BAND SPECTRUM (dBA without tone adjustment)						
<b>TO COME</b>								
113-174200	73.0	73.4	73.0	71.2	69.0	62.7	59.2	55.1

**NOTE:** Tested in accordance with AHRI Standard 270-08 (not listed in AHRI)

## Unit Dimensions

MODEL NO.	OPERATING						SHIPPING					
	H (Height)		L (Length)		W (Width)		H (Height)		L (Length)		W (Width)	
	INCHES	mm	INCHES	mm	INCHES	mm	INCHES	mm	INCHES	mm	INCHES	mm
RA13NZ18	25.00	635	29.75	756	29.75	756	26.50	673	32.38	822	32.38	822
RA13NZ24	25.00	635	33.75	857	33.75	857	26.50	673	36.38	924	36.38	924
RA13NZ30	25.00	635	33.75	857	33.75	857	26.50	673	36.38	924	36.38	924
RA13NZ36	35.00	889	33.75	857	33.75	857	36.50	927	36.38	924	36.38	924
RA13NZ42	27.00	686	33.75	857	33.75	857	28.50	724	36.38	924	36.38	924
RA13NZ48	39.00	991	35.75	908	35.75	908	40.50	1029	38.38	975	38.38	975
RA13NZ60	45.00	1143	35.75	908	35.75	908	46.50	1181	38.38	975	38.38	975

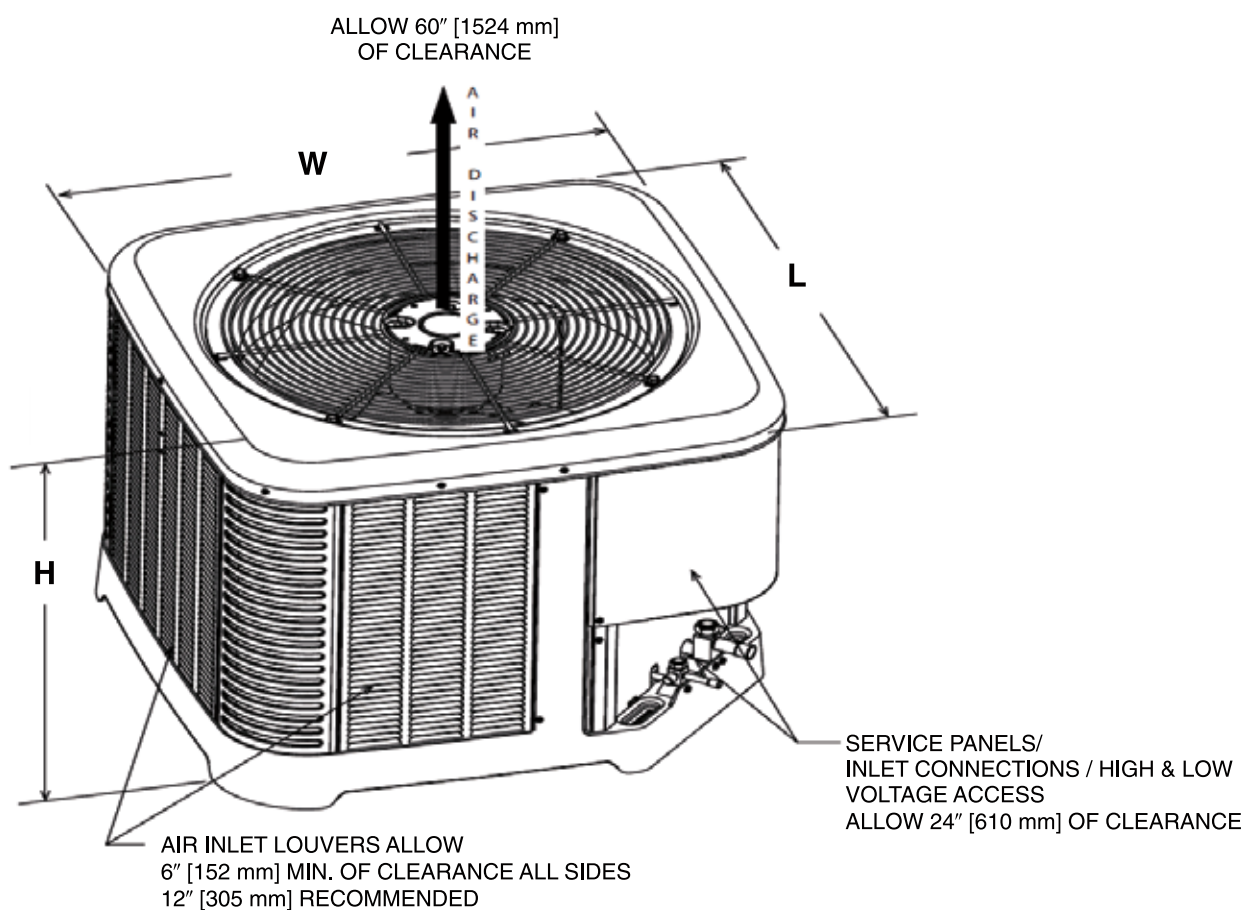

[ ] Designates Metric Conversions

ST-A1226-02-00

# CLEARANCES

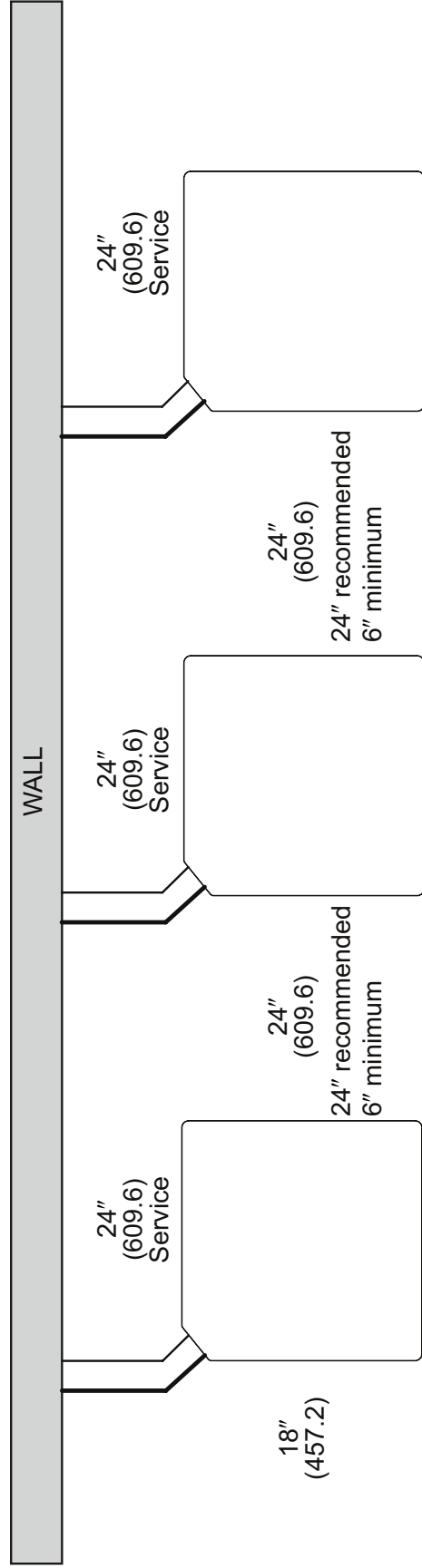
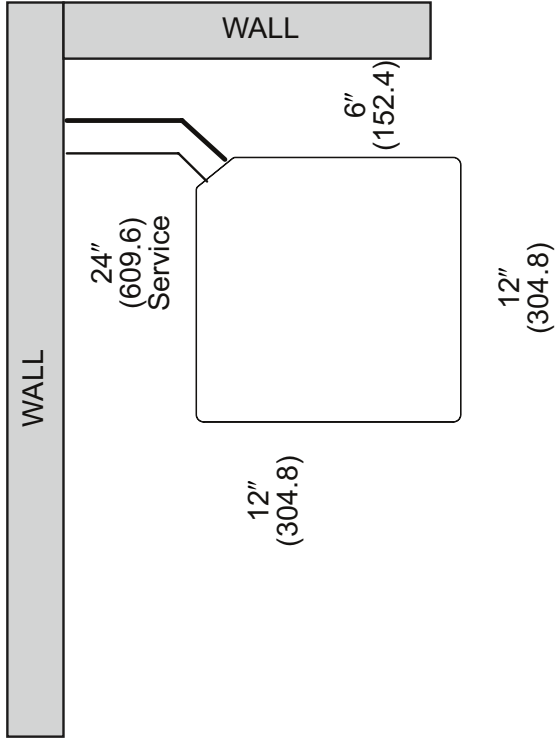
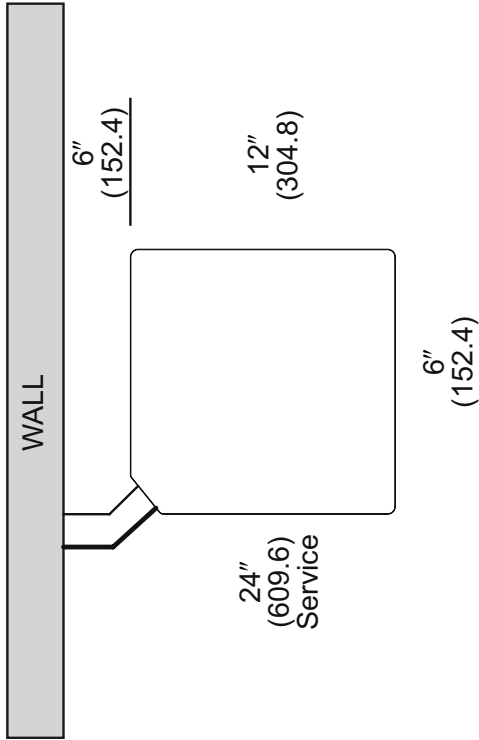

**NOTE: NUMBERS IN ( ) = mm**

**IMPORTANT:** When installing multiple units in an alcove, roof well or partially enclosed area, ensure there is adequate ventilation to prevent re-circulation of discharge air.



## Control Wiring

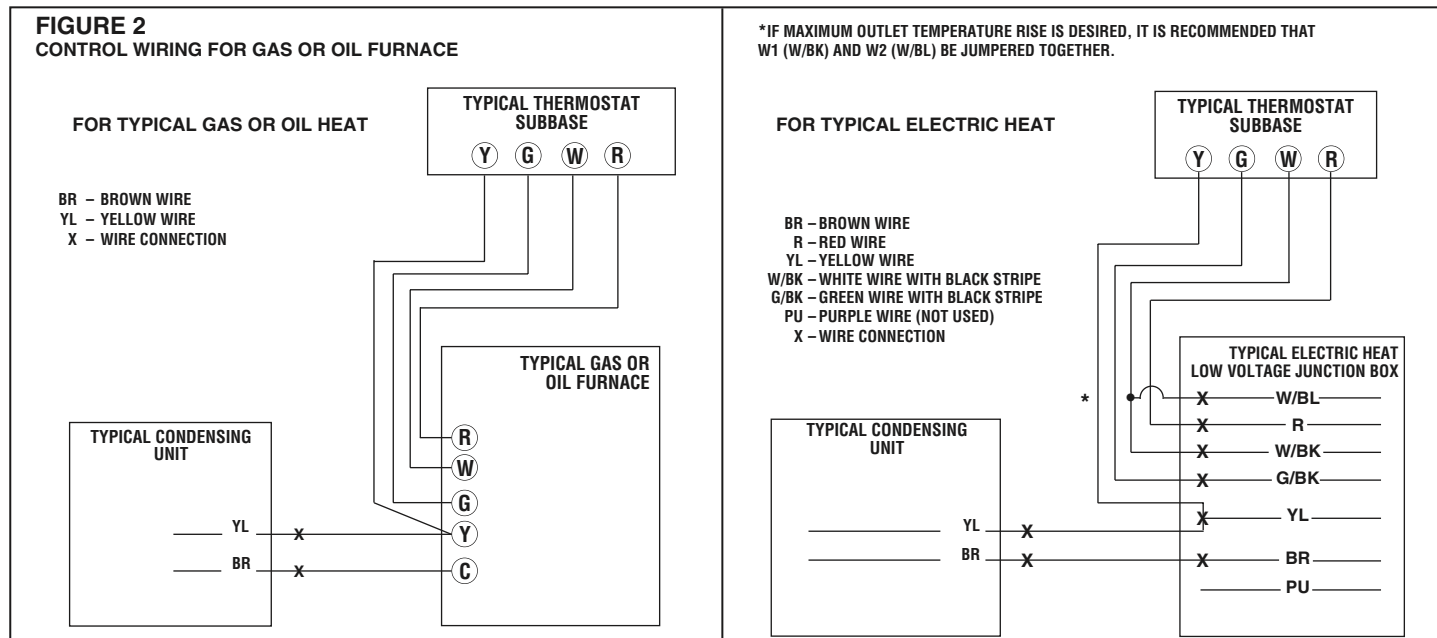

## Application Guidelines

1. Intended for outdoor installation with free air inlet and outlet. Outdoor fan external static pressure available is less than 0.01 -in. wc.
2. Minimum outdoor operation air temperature for cooling mode without low-ambient operation accessory is 55°F (12.8°C).
3. Maximum outdoor operating air temperature is 125°F (51.7°C).
4. For reliable operation, unit should be level in all horizontal planes.
5. Use only copper wire for electric connections at unit. Aluminum and clad aluminum are not acceptable for the type of connector provided.
6. Do not apply capillary tube indoor coils to these units.
7. Factory-supplied filter drier must be installed.

# Refrigerant Line Size Information

13.4 SEER2 Single-Stage Air-Conditioners													
Unit Size	Allowable Liquid Line Size	Allowable Suction Line Size	Apply Long Line Guidelines if Linear Line Length Exceeds Those Shown Below (Feet)	Equivalent Length (Feet)									
				Maximum Vertical Rise (Outdoor Unit Below Indoor Unit) * / Capacity Multiplier									
				< 25	26-50	51-75	76-100	101-125	126-150	151-175	176-200	201-225	226-250
1.5 Ton **SEE NOTE 3	1/4"	5/8"	N/A	25/1.00	50/0.99	62/0.98	43/0.98	24/0.97	57/0.97	NR	NR	NR	NR
	5/16"	5/8"	N/A	25/1.00	50/0.99	75/0.98	98/0.98	93/0.97	88/0.97	83/0.96	78/0.96	73/0.95	68/0.94
	3/8"	5/8"	178	25/1.00	50/0.99	75/0.98	100/0.98	100/0.97	100/0.97	100/0.96	100/0.96	100/0.95	100/0.94
	1/4"	3/4"	N/A	25/1.00	50/1.00	62/0.99	43/0.99	24/0.99	57/0.99	NR	NR	NR	NR
	5/16"	3/4"	N/A	25/1.00	50/1.00	75/0.99	98/0.99	93/0.99	88/0.99	83/0.99	78/0.98	73/0.98	68/0.98
	3/8"	3/4"	178	25/1.00	50/1.00	75/1.00	100/0.99	100/0.99	100/0.99	100/0.99	100/0.98	100/0.98	100/0.98
	1/4"	5/8"	N/A	25/0.99	50/0.98	21/0.97	NR	NR	NR	NR	NR	NR	NR
	5/16"	5/8"	213	25/0.99	50/0.98	75/0.97	87/0.96	77/0.95	69/0.94	61/0.93	53/0.92	45/0.91	37/0.90
2 Ton	3/8"	5/8"	142	25/0.99	50/0.98	75/0.97	100/0.96	100/0.95	100/0.94	98/0.93	95/0.92	92/0.91	89/0.90
	1/4"	3/4"	N/A	25/1.00	50/1.00	21/0.99	NR	NR	NR	NR	NR	NR	NR
	5/16"	3/4"	213	25/1.00	50/1.00	75/0.99	87/0.99	77/0.98	69/0.98	61/0.98	53/0.97	45/0.97	37/0.96
	3/8"	3/4"	142	25/1.00	50/1.00	75/0.99	100/0.99	100/0.98	100/0.98	98/0.98	95/0.97	93/0.97	90/0.96
2.5 Ton	5/16"	5/8"	N/A	25/0.99	50/0.98	75/0.96	70/0.94	59/0.93	48/0.91	36/0.90	NR	NR	NR
	3/8"	5/8"	142	25/0.99	50/0.98	75/0.96	100/0.94	98/0.93	94/0.91	90/0.90	NR	NR	NR
	5/16"	3/4"	213	25/1.00	50/0.99	75/0.99	70/0.98	59/0.98	48/0.97	36/0.96	25/0.96	13/0.95	NR
	3/8"	3/4"	142	25/1.00	50/0.99	75/0.99	100/0.98	98/0.98	94/0.97	90/0.96	86/0.96	82/0.95	78/0.95
3 Ton	5/16"	5/8"	N/A	25/0.99	50/0.97	66/0.94	49/0.92	32/0.90	NR	NR	NR	NR	NR
	3/8"	5/8"	108	25/0.99	50/0.97	75/0.94	95/0.92	89/0.90	NR	NR	NR	NR	NR
	5/16"	3/4"	N/A	25/1.00	50/0.99	66/0.98	49/0.98	32/0.97	15/0.96	NR	NR	NR	NR
	3/8"	3/4"	108	25/1.00	50/0.99	75/0.98	95/0.98	89/0.97	84/0.96	78/0.95	72/0.94	67/0.93	61/0.93
	1/2"	3/4"	54	25/1.00	50/0.99	75/0.98	100/0.98	100/0.97	100/0.96	100/0.95	100/0.94	100/0.93	100/0.93
	5/16"	7/8"	N/A	25/1.00	50/1.00	66/1.00	49/0.99	32/0.99	15/0.99	NR	NR	NR	NR
	3/8"	7/8"	108	25/1.00	50/1.00	75/1.00	95/0.99	89/0.99	84/0.99	78/0.98	72/0.98	67/0.98	61/0.97
	1/2"	7/8"	54	25/1.00	50/1.00	75/1.00	100/0.99	100/0.99	100/0.99	100/0.98	100/0.98	100/0.98	100/0.97
3.5 Ton	3/8"	3/4"	150	25/0.99	50/0.98	75/0.97	88/0.96	80/0.95	72/0.94	65/0.92	57/0.91	49/0.90	NR
	1/2"	3/4"	75	25/0.99	50/0.98	75/0.97	100/0.96	100/0.95	100/0.94	100/0.92	100/0.91	100/0.90	NR
	3/8"	7/8"	150	25/1.00	50/1.00	75/0.99	88/0.99	80/0.99	72/0.98	65/0.97	57/0.97	49/0.96	42/0.96
	1/2"	7/8"	75	25/1.00	50/1.00	75/0.99	100/0.99	100/0.99	100/0.98	100/0.97	100/0.97	100/0.96	100/0.96

**NOTES:**

- 1) Do not exceed 200 ft linear line length.
- 2) \*Do not exceed 100 ft vertical separation if outdoor unit is above indoor unit.
- 3) \*\*3/4" suction line should only be used for 1.5 ton systems if outdoor unit is below or at same level as indoor to assure proper oil return.
- 4) Always use the smallest liquid line allowable to minimize refrigerant charge.
- 5) Applications shaded in light gray indicate capacity multipliers between 0.90 and 0.96 which are not recommended, but are allowed.
- 6) Applications shaded in dark gray are not recommended due to excessive liquid or suction pressure drop.

## Refrigerant Line Size Information (con't.)

13.4 SEER2 Single-Stage Air-Conditioners													
Unit Size	Allowable Liquid Line Size	Allowable Suction Line Size	Apply Long Line Guidelines if Linear Line Length Exceeds Those Shown Below (Feet)	Equivalent Length (Feet)									
				< 25	26-50	51-75	76-100	101-125	126-150	151-175	176-200	201-225	226-250
				Maximum Vertical Rise (Outdoor Unit Below Indoor Unit) * / Capacity Multiplier									
4 Ton	3/8"	3/4"	148	25 / 0.99	50 / 0.98	75 / 0.96	77 / 0.95	67 / 0.93	57 / 0.92	46 / 0.91	NR	NR	NR
	1/2"	3/4"	74	25 / 0.99	50 / 0.98	75 / 0.96	100 / 0.95	100 / 0.93	100 / 0.92	100 / 0.91	NR	NR	NR
	3/8"	7/8"	148	25 / 1.00	50 / 0.99	75 / 0.99	77 / 0.98	67 / 0.97	57 / 0.97	46 / 0.96	36 / 0.96	26 / 0.95	15 / 0.95
	1/2"	7/8"	74	25 / 1.00	50 / 0.99	75 / 0.99	100 / 0.98	100 / 0.97	100 / 0.97	100 / 0.96	100 / 0.96	99 / 0.95	97 / 0.95
	3/8"	3/4"	78	25 / 0.99	50 / 0.97	75 / 0.94	61 / 0.92	46 / 0.90	NR	NR	NR	NR	NR
	1/2"	3/4"	39	25 / 0.99	50 / 0.97	75 / 0.94	100 / 0.92	100 / 0.90	NR	NR	NR	NR	NR
5 Ton	3/8"	7/8"	78	25 / 1.00	50 / 0.99	75 / 0.98	61 / 0.97	46 / 0.96	32 / 0.95	18 / 0.94	NR	NR	NR
	1/2"	7/8"	39	25 / 1.00	50 / 0.99	75 / 0.98	100 / 0.97	100 / 0.96	100 / 0.95	97 / 0.94	95 / 0.94	92 / 0.93	89 / 0.92
	3/8"	1-1/8"	78	25 / 1.01	50 / 1.01	75 / 1.00	61 / 1.00	46 / 0.99	32 / 0.99	18 / 0.99	NR	NR	NR
	1/2"	1-1/8"	39	25 / 1.01	50 / 1.01	75 / 1.00	100 / 1.00	100 / 0.99	100 / 0.99	97 / 0.99	95 / 0.99	92 / 0.99	89 / 0.98

**NOTES:**

- 1) Do not exceed 200 ft linear line length.
- 2) \*Do not exceed 100 ft vertical separation if outdoor unit is above indoor unit.
- 3) \*\*3/4" suction line should only be used for 1.5 ton systems if outdoor unit is below or at same level as indoor to assure proper oil return.
- 4) Always use the smallest liquid line allowable to minimize refrigerant charge.
- 5) Applications shaded in light gray indicate capacity multipliers between 0.90 and 0.96 which are not recommended, but are allowed.
- 6) Applications shaded in dark gray are not recommended due to excessive liquid or suction pressure drop.

# Refrigerant Line Size Information

13.4 SEER2 Single-Stage Air-Conditioners													
Unit Size	Allowable Liquid Line Size mm [in.]	Allowable Suction Line Size mm [in.]	Apply Long Line Guidelines if Linear Line Length Exceeds Those Shown Below (Feet)	Equivalent Length (Meters)								70-76	
				< 8	8-15	16-23	24-30	31-38	39-46	47-53	54-61		62-69
				Maximum Vertical Rise (Outdoor Unit Below Indoor Unit) * / Capacity Multiplier									
(-)A13NZ				8 / 1.00	15 / 0.99	19 / 0.98	13 / 0.98	7 / 0.97	2 / 0.97	NR	NR	NR	NR
5.3 KW [1.5 Ton] **SEE NOTE 3		15.88 [5/8]	N/A	8 / 1.00	15 / 0.99	19 / 0.98	13 / 0.98	7 / 0.97	2 / 0.97	NR	NR	NR	NR
		15.88 [5/8]	N/A	8 / 1.00	15 / 0.99	23 / 0.98	30 / 0.98	28 / 0.97	27 / 0.97	25 / 0.96	22 / 0.95	22 / 0.95	21 / 0.94
		15.88 [5/8]	54	8 / 1.00	15 / 0.99	23 / 0.98	30 / 0.98	30 / 0.97	30 / 0.97	30 / 0.96	30 / 0.96	30 / 0.95	30 / 0.94
		19.05 [3/4]**	N/A	8 / 1.00	15 / 1.00	19 / 0.99	13 / 0.99	7 / 0.99	2 / 0.99	NR	NR	NR	NR
7.0 KW [2 Ton]		19.05 [3/4]**	N/A	8 / 1.00	15 / 1.00	23 / 0.99	30 / 0.99	30 / 0.99	30 / 0.99	30 / 0.99	30 / 0.98	30 / 0.98	30 / 0.98
		19.05 [3/4]**	54	8 / 1.00	15 / 1.00	23 / 0.99	30 / 0.99	30 / 0.99	30 / 0.99	30 / 0.99	30 / 0.99	30 / 0.98	30 / 0.98
		15.88 [5/8]	N/A	8 / 0.99	15 / 0.98	6 / 0.97	NR	NR	NR	NR	NR	NR	NR
		15.88 [5/8]	65	8 / 0.99	15 / 0.98	23 / 0.97	27 / 0.96	23 / 0.95	21 / 0.94	19 / 0.93	16 / 0.92	14 / 0.91	11 / 0.90
8.8 KW [2.5 Ton]		15.88 [5/8]	43	8 / 0.99	15 / 0.98	23 / 0.97	30 / 0.96	30 / 0.95	30 / 0.94	30 / 0.93	29 / 0.92	28 / 0.91	27 / 0.90
		19.05 [3/4]	N/A	8 / 1.00	15 / 1.00	6 / 0.99	NR	NR	NR	NR	NR	NR	NR
		19.05 [3/4]	65	8 / 1.00	15 / 1.00	23 / 0.99	27 / 0.99	23 / 0.98	21 / 0.98	18 / 0.97	15 / 0.96	14 / 0.95	11 / 0.94
		19.05 [3/4]	43	8 / 1.00	15 / 0.99	23 / 0.99	30 / 0.98	30 / 0.98	30 / 0.98	29 / 0.97	27 / 0.96	25 / 0.95	24 / 0.95
10.6 KW [3 Ton]		15.88 [5/8]	N/A	8 / 0.99	15 / 0.97	20 / 0.94	15 / 0.92	10 / 0.90	NR	NR	NR	NR	NR
		15.88 [5/8]	33	8 / 0.99	15 / 0.97	23 / 0.94	29 / 0.92	27 / 0.90	NR	NR	NR	NR	NR
		19.05 [3/4]	N/A	8 / 1.00	15 / 0.99	20 / 0.98	15 / 0.98	10 / 0.97	5 / 0.96	NR	NR	NR	NR
		19.05 [3/4]	33	8 / 1.00	15 / 0.99	23 / 0.98	29 / 0.98	27 / 0.97	26 / 0.96	24 / 0.95	22 / 0.94	20 / 0.93	19 / 0.93
12.3 KW [3.5 Ton]		19.05 [3/4]	17	8 / 1.00	15 / 0.99	23 / 0.98	30 / 0.98	30 / 0.97	30 / 0.96	30 / 0.95	30 / 0.94	30 / 0.93	30 / 0.93
		22.23 [7/8]	N/A	8 / 1.00	15 / 1.00	20 / 1.00	15 / 0.99	10 / 0.99	5 / 0.99	NR	NR	NR	NR
		22.23 [7/8]	33	8 / 1.00	15 / 1.00	23 / 1.00	29 / 0.99	27 / 0.99	26 / 0.99	24 / 0.98	22 / 0.98	20 / 0.98	19 / 0.97
		22.23 [7/8]	17	8 / 1.00	15 / 1.00	23 / 1.00	30 / 0.99	30 / 0.99	30 / 0.99	30 / 0.99	30 / 0.98	30 / 0.98	30 / 0.97
12.3 KW [3.5 Ton]		19.05 [3/4]	46	8 / 0.99	15 / 0.98	23 / 0.97	27 / 0.96	24 / 0.95	22 / 0.94	20 / 0.92	17 / 0.91	15 / 0.90	NR
		19.05 [3/4]	23	8 / 0.99	15 / 0.98	23 / 0.97	30 / 0.96	30 / 0.95	30 / 0.94	30 / 0.92	30 / 0.91	30 / 0.90	NR
		22.23 [7/8]	46	8 / 1.00	15 / 1.00	23 / 0.99	27 / 0.99	24 / 0.99	22 / 0.98	20 / 0.97	17 / 0.97	15 / 0.96	13 / 0.96
		22.23 [7/8]	23	8 / 1.00	15 / 1.00	23 / 0.99	30 / 0.99	30 / 0.99	30 / 0.98	30 / 0.97	30 / 0.97	30 / 0.96	30 / 0.96

**NOTES:**

- 1) Do not exceed 200 ft linear line length.
- 2) \*Do not exceed 100 ft vertical separation if outdoor unit is above indoor unit.
- 3) \*\*3/4" suction line should only be used for 1.5 ton systems if outdoor unit is below or at same level as indoor to assure proper oil return.
- 4) Always use the smallest liquid line allowable to minimize refrigerant charge.
- 5) Applications shaded in light gray indicate capacity multipliers between 0.90 and 0.96 which are not recommended, but are allowed.
- 6) Applications shaded in dark gray are not recommended due to excessive liquid or suction pressure drop.

## Refrigerant Line Size Information (con't.)

13.4 SEER2 Single-Stage Air-Conditioners													
Unit Size	Allowable Liquid Line Size mm [in.]	Allowable Suction Line Size mm [in.]	Apply Long Line Guidelines if Linear Line Length Exceeds Those Shown Below (Feet)	Equivalent Length (Meters)									
				< 25	26-50	51-75	76-100	101-125	126-150	151-175	176-200	201-225	226-250
				Maximum Vertical Rise (Outdoor Unit Below Indoor Unit) * / Capacity Multiplier									
14.1 KW [4 Ton]	9.53 [3/8]	19.05 [3/4]	45	8 / 0.99	15 / 0.98	23 / 0.96	24 / 0.95	20 / 0.93	17 / 0.92	14 / 0.91	NR	NR	NR
	12.7 [1/2]	19.05 [3/4]	23	8 / 0.99	15 / 0.98	23 / 0.96	30 / 0.95	30 / 0.93	30 / 0.92	30 / 0.91	NR	NR	NR
	9.53 [3/8]	22.23 [7/8]	45	8 / 1.00	15 / 0.99	23 / 0.99	24 / 0.98	20 / 0.97	17 / 0.97	14 / 0.96	11 / 0.96	8 / 0.95	5 / 0.95
	12.7 [1/2]	22.23 [7/8]	23	8 / 1.00	15 / 0.99	23 / 0.99	30 / 0.98	30 / 0.97	30 / 0.97	30 / 0.96	30 / 0.96	30 / 0.95	30 / 0.95
	9.53 [3/8]	19.05 [3/4]	24	8 / 0.99	15 / 0.97	23 / 0.94	19 / 0.92	14 / 0.90	NR	NR	NR	NR	NR
	12.7 [1/2]	19.05 [3/4]	12	8 / 0.99	15 / 0.97	23 / 0.94	30 / 0.92	30 / 0.90	NR	NR	NR	NR	NR
17.6 KW [5 Ton]	9.53 [3/8]	22.23 [7/8]	24	8 / 1.00	15 / 0.99	23 / 0.98	19 / 0.97	14 / 0.96	10 / 0.95	5 / 0.94	NR	NR	NR
	12.7 [1/2]	22.23 [7/8]	12	8 / 1.00	15 / 0.99	23 / 0.98	30 / 0.97	30 / 0.96	30 / 0.95	30 / 0.94	29 / 0.94	28 / 0.93	27 / 0.92
	9.53 [3/8]	28.58 [1-1/8]	24	8 / 1.01	15 / 1.01	23 / 1.00	19 / 1.00	14 / 0.99	10 / 0.99	5 / 0.99	NR	NR	NR
	12.7 [1/2]	28.58 [1-1/8]	12	8 / 1.01	15 / 1.01	23 / 1.00	30 / 1.00	30 / 0.99	30 / 0.99	30 / 0.99	29 / 0.99	28 / 0.99	27 / 0.98

**NOTES:**

- 1) Do not exceed 200 ft linear line length.
- 2) \*Do not exceed 100 ft vertical separation if outdoor unit is above indoor unit.
- 3) \*\*3/4" suction line should only be used for 1.5 ton systems if outdoor unit is below or at same level as indoor to assure proper oil return.
- 4) Always use the smallest liquid line allowable to minimize refrigerant charge.
- 5) Applications shaded in light gray indicate capacity multipliers between 0.90 and 0.96 which are not recommended, but are allowed.
- 6) Applications shaded in dark gray are not recommended due to excessive liquid or suction pressure drop.

## Performance Data @ AHRI Standard Conditions – Cooling

Designated Tested Combination (DTC)							
Outdoor Unit	Indoor Coil	Total Capacity BTU/H [kW]	Net Sensible BTU/H [kW]	Net Latent BTU/H [kW]	SEER2	EER2	Indoor CFM [L/s]
RA13NZ18AJ1	RCFZ2417STAN	17100 [5.0]	13000 [3.8]	4,100	13.4	9.0	600 [283.2]
RA13NZ24AJ1	RCFZ2417STAN	22800 [6.7]	17000 [5.0]	5,800	13.4	9.0	735 [346.9]
RA13NZ30AJ1	RCFZ3617STAN	28400 [8.3]	20800 [6.1]	7,600	13.4	9.0	910 [429.5]
RA13NZ36AJ1	RCFZ3617STAN	34200 [10.0]	24600 [7.2]	9,600	13.4	9.0	1025 [483.7]
RA13NZ42AJ1	RCFZ4821STAN	40000 [11.7]	29500 [8.6]	10,500	13.4	9.0	1300 [613.5]
RA13NZ48AJ1	RCFZ4821STAN	46000 [13.5]	33500 [9.8]	12,500	13.4	9.0	1425 [672.5]
RA13NZ60AJ1	RCFZ6024STAN	55500 [16.3]	39000 [11.4]	16,500	13.4	9.0	1600 [755.1]

**NOTE:** This data includes DTC (Designated Test Combination) ratings and is for reference purposes only. A full listing of official ratings and system match-ups, along with downloadable certificates, can be accessed from the AHRI website: [www.ahridirectory.org](http://www.ahridirectory.org).

[ ] Designates Metric Conversions





**GENERAL TERMS OF LIMITED WARRANTY\***

Ruud will furnish a replacement for any part of this product which fails in normal use and service within the applicable period stated, in accordance with the terms of the limited warranty.

**\*For complete details of the Limited and Conditional Warranties, including applicable terms and conditions, contact your local contractor or the Manufacturer for a copy of the product warranty certificate.**

Conditional Parts  
(Registration Required)..... Ten (10) Years

**Before proceeding with installation, refer to installation instructions packaged with each model, as well as complying with all Federal, State, Provincial, and Local codes, regulations, and practices.**

*In keeping with its policy of continuous progress and product improvement, Ruud reserves the right to make changes without notice.*

Ruud Heating, Cooling & Water Heating • 5600 Old Greenwood Road  
Fort Smith, Arkansas 72908 • [www.ruud.com](http://www.ruud.com)

Ruud Canada Ltd./Ltée • 125 Edgeware Road, Unit 1  
Brampton, Ontario • L6Y 0P5