

PART NUMBER	MODEL	A	B	C	D	DETAIL VIEW
497-1352-00	CR24K6/E-PFV-879	13.054	11.195	5.86	10.165	V
497-1352-01	CR30K6/E-PFV-879	13.424	11.565	5.86	10.535	V
497-1352-02	CR35K6/E-PFV-879	13.674	11.815	5.86	10.785	V
497-1352-03	CR38K6/E-PFV-879	13.924	12.065	5.86	11.035	V
497-1352-04	CR42K6/E-PFV-879	14.174	12.315	5.86	11.285	V
497-1352-05	CR47KQ/E-PFV-979	14.41	14.30	5.86	1.67	Y
497-1352-06	CRN5-0500-PFV-979 CRN0-050E-PFV-979	15.717	15.288	2.78	2.32	W

SPECIFICATIONS	
ES NO.	DESCRIPTION
ES22-122	PACKAGING
ES81-159	CLEANLINESS
ES81-250	IDENTIFICATION
ES92-167	REGULATORY COMPLIANCE

- NOTES:
- TOLERANCES TO BE ± 0.12 UNLESS OTHERWISE SPECIFIED.
 - TUBE ENDS MUST BE PLUGGED.
 - FOR MODEL APPLICATION REFER TO CHART
 - MODEL SE INCLUDES CRANKCASE HEATER

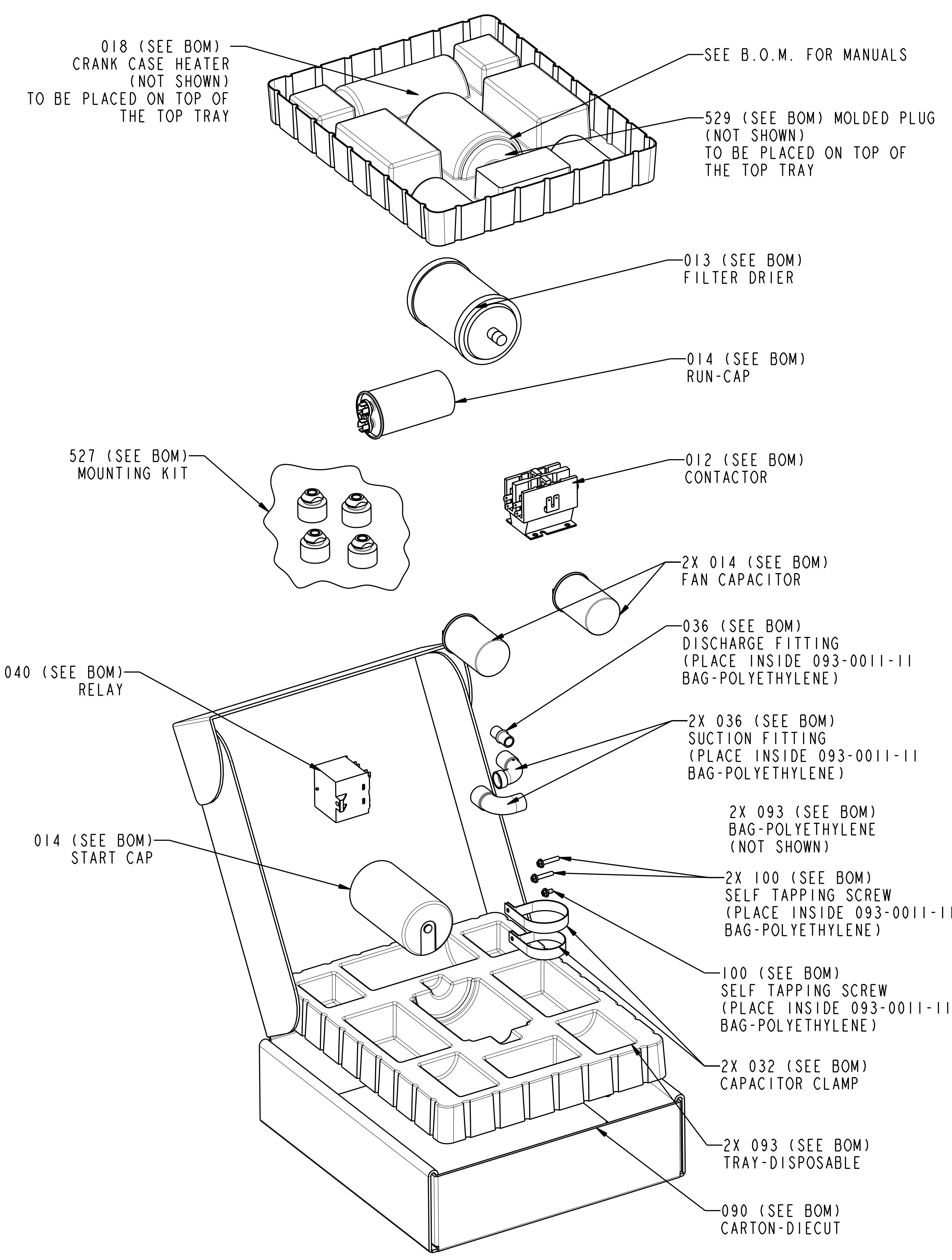

568 (SEE BOM) PREMIUM KIT

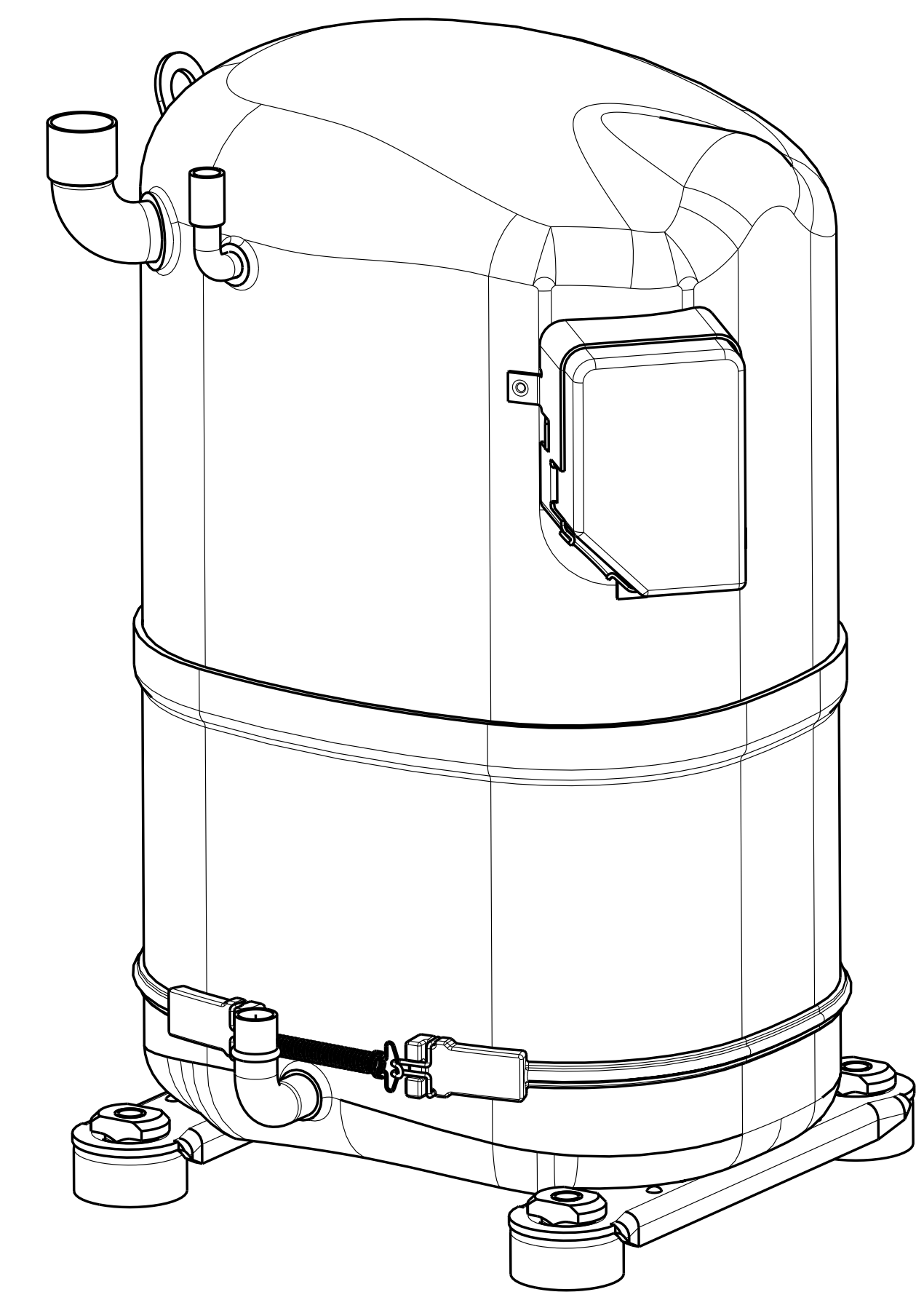

CRN/CRP MODEL

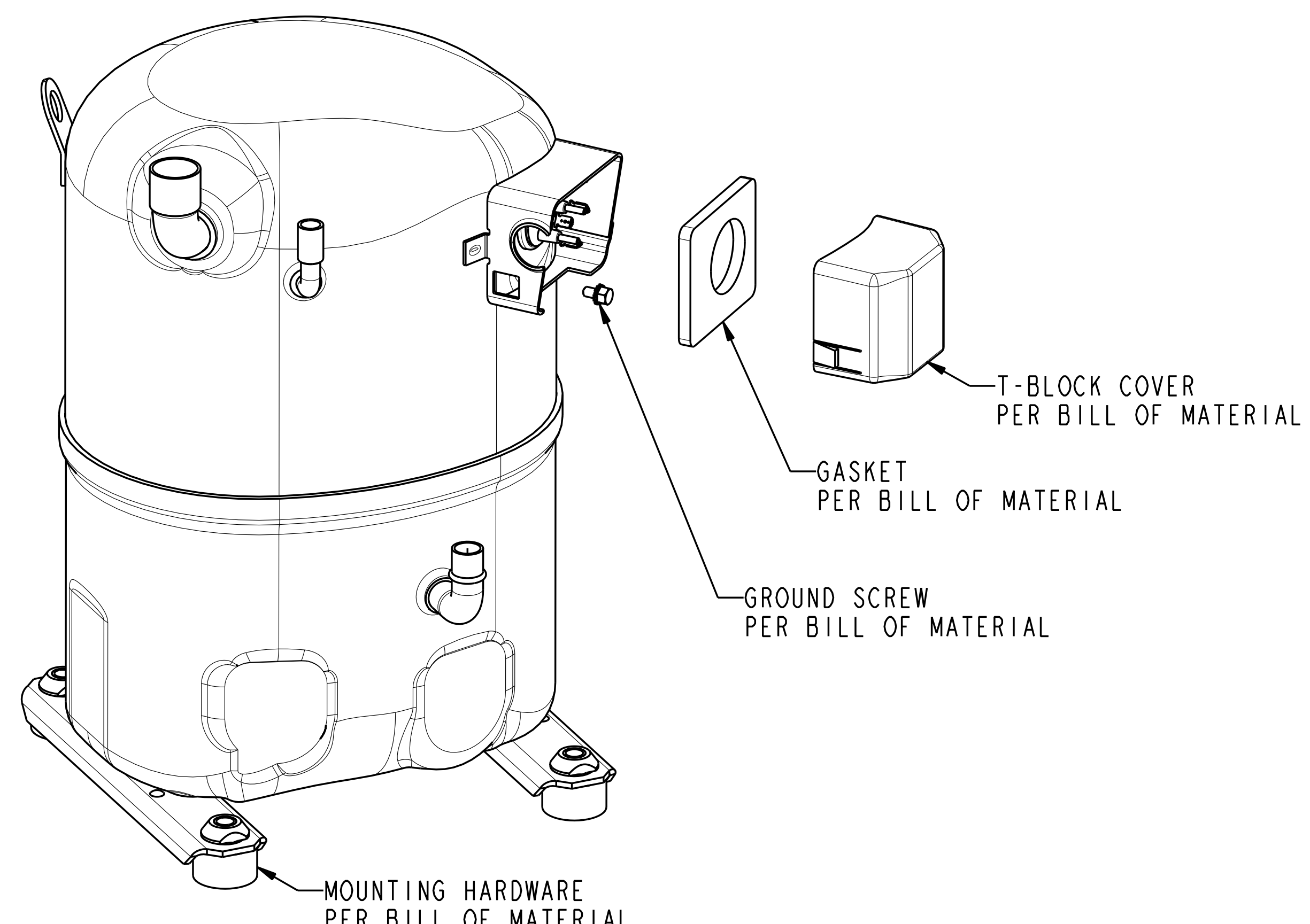

CRKQ MODEL

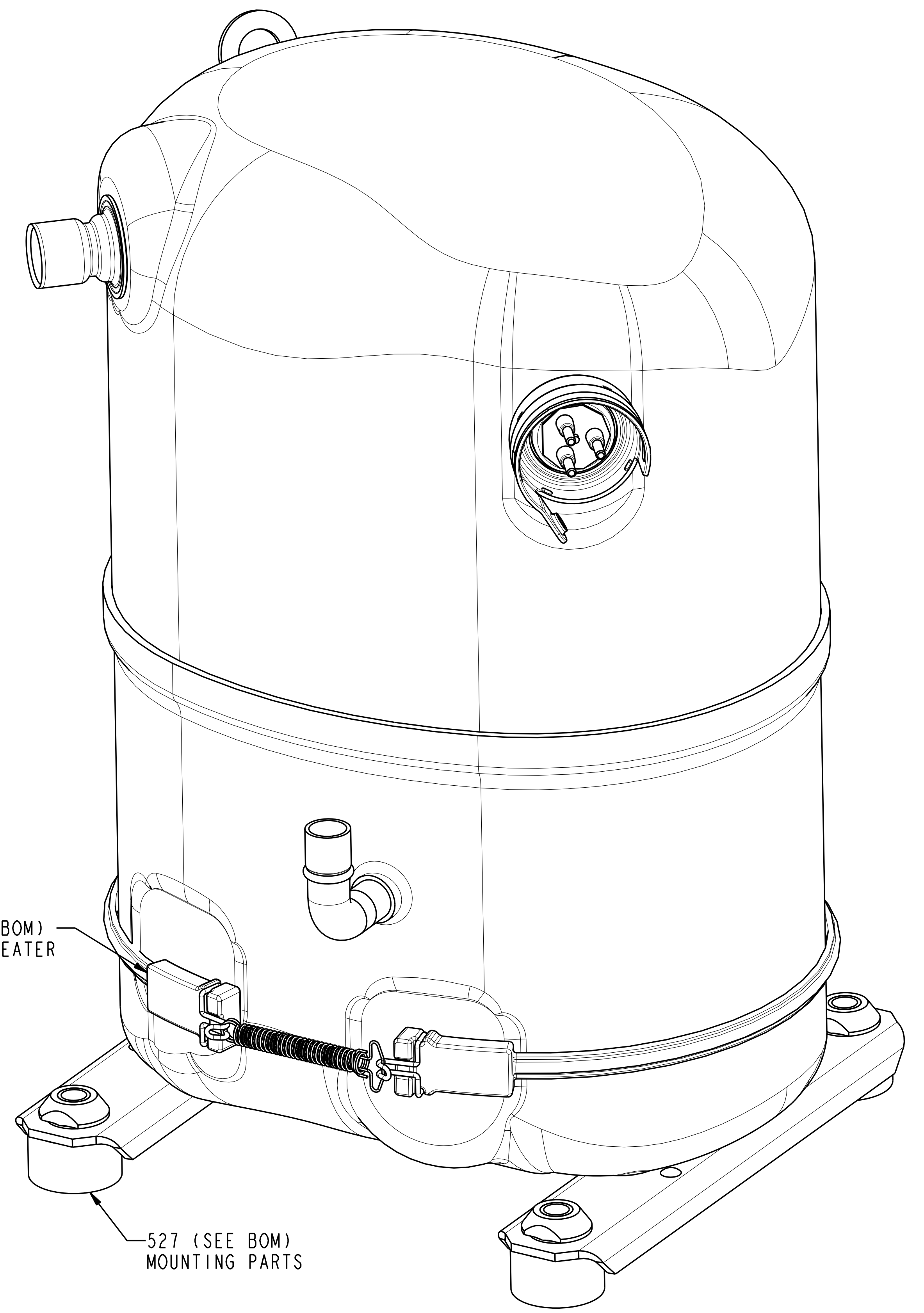

CRK6 MODEL

	INTERPRET PER ASME Y14.5M-1994 AND EMERSON CLIMATE TECHNOLOGIES, INC. DESIGN STANDARDS DS2002 DO NOT SCALE DRAWING	CONFIDENTIALITY NOTICE THIS DRAWING AND INFORMATION CONTAINED HEREIN ARE THE EXCLUSIVE PROPERTY OF EMERSON CLIMATE TECHNOLOGIES, INC. AND SHALL BE RETURNED UPON DEMAND AND SHALL NOT BE REPRODUCED IN WHOLE OR IN PART, DISCLOSED TO ANYONE ELSE OR USED, WITHOUT THE WRITTEN CONSENT OF EMERSON CLIMATE TECHNOLOGIES, INC.
	CRITICAL PRODUCT CHARACTERISTIC UNLESS OTHERWISE SPECIFIED DIMENSIONS ARE INCH OR (MILLIMETER) TOLERANCES: 2-PLACE \pm N/A 3-PLACE \pm N/A ANGULAR \pm N/A	DRAWN BY: PAS DATE: 03-07-12 SCALE: 3:8 DATE FORMAT: MM-DD-YY
	TITLE: REF - COMPRESSOR DWG	DRAWING NUMBER SHEET 1 OF 2 497-1352-00

UNCONTROLLED - DO NOT MODIFY

COPYRIGHT EMERSON CLIMATE TECHNOLOGIES, INC. - CONFIDENTIAL

CC HEATER LOCATION FOR CRK6/CRKQ MODELS

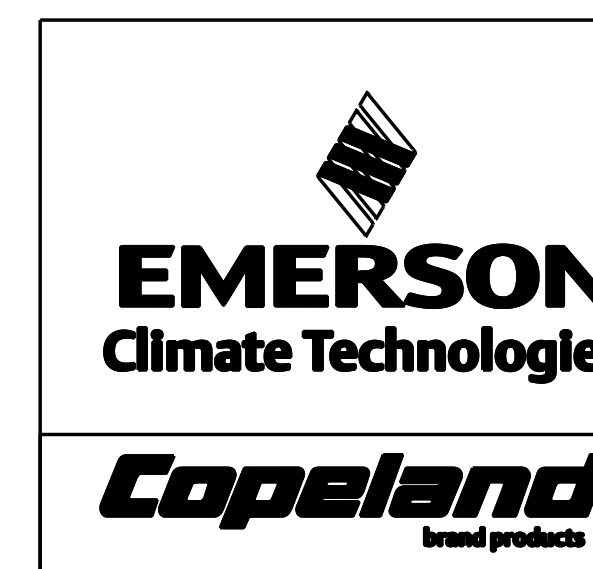
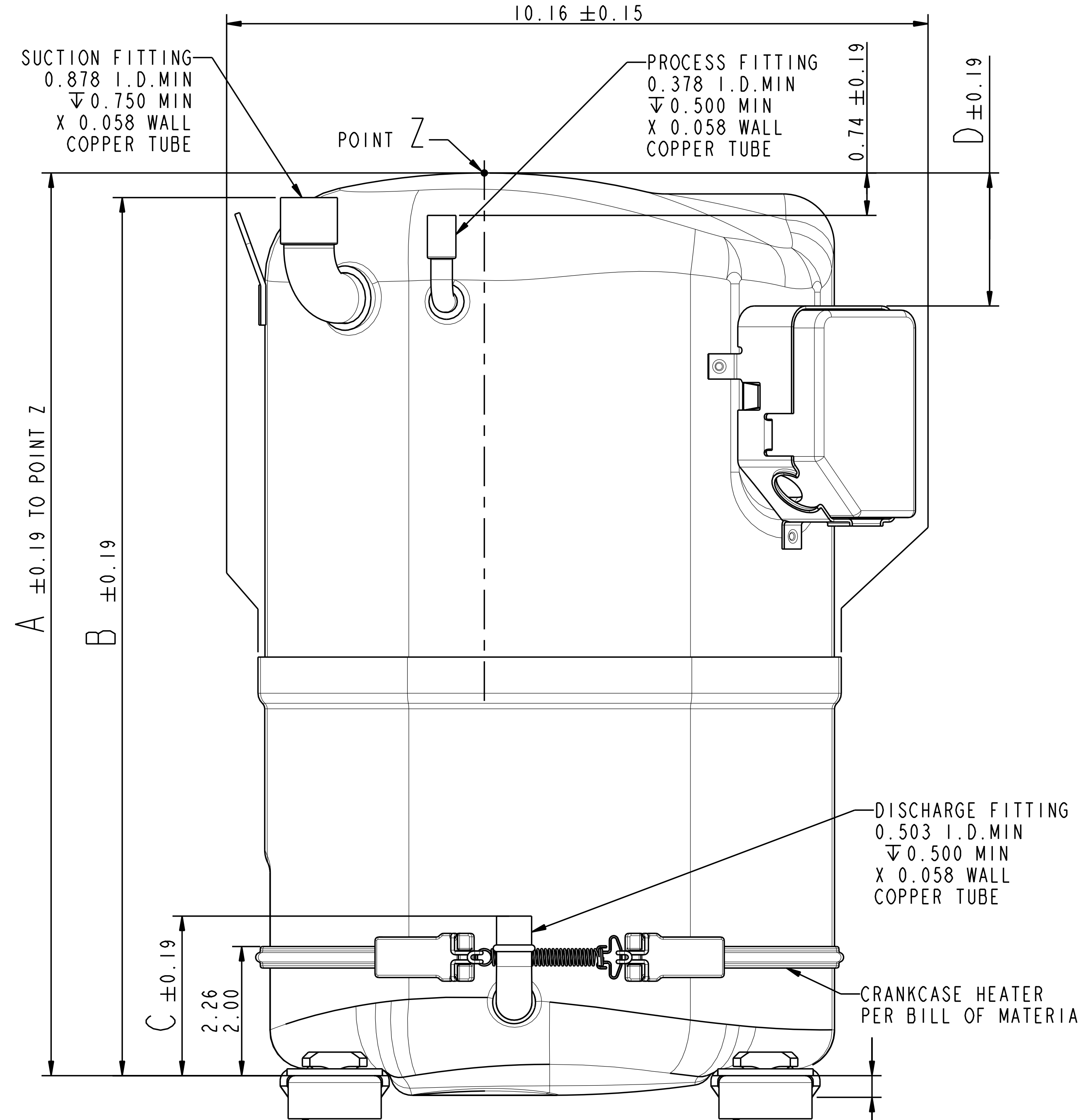
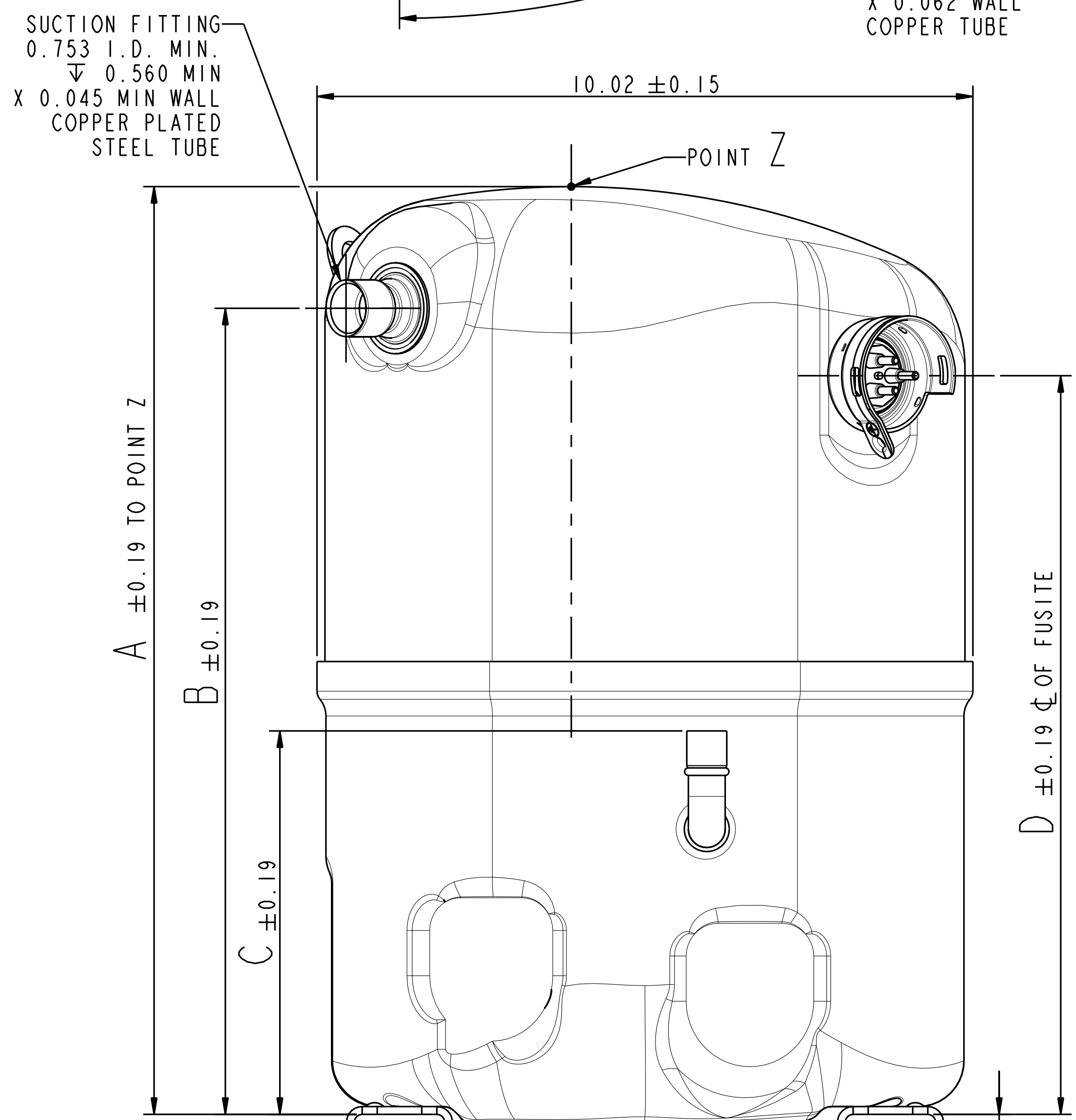
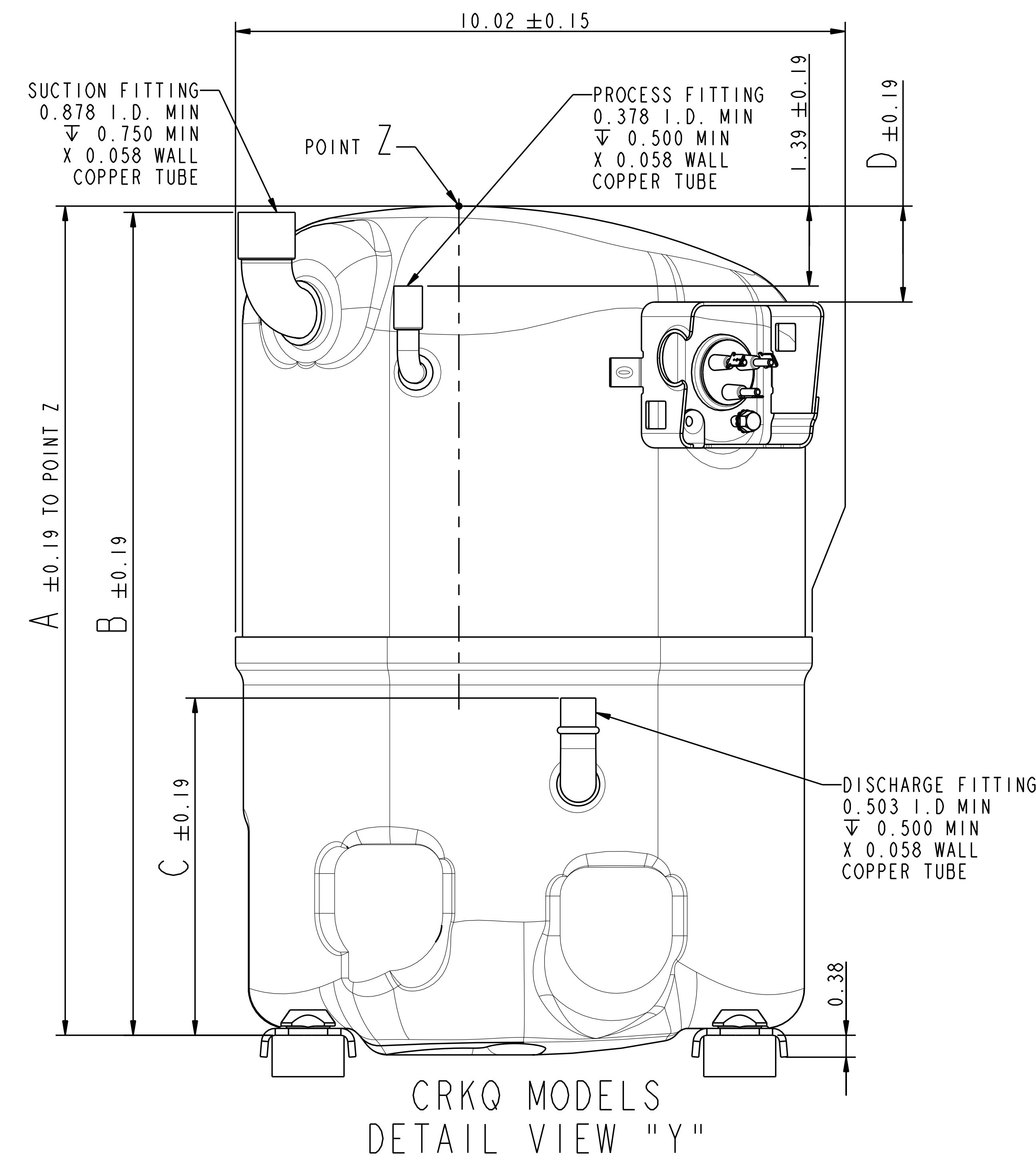
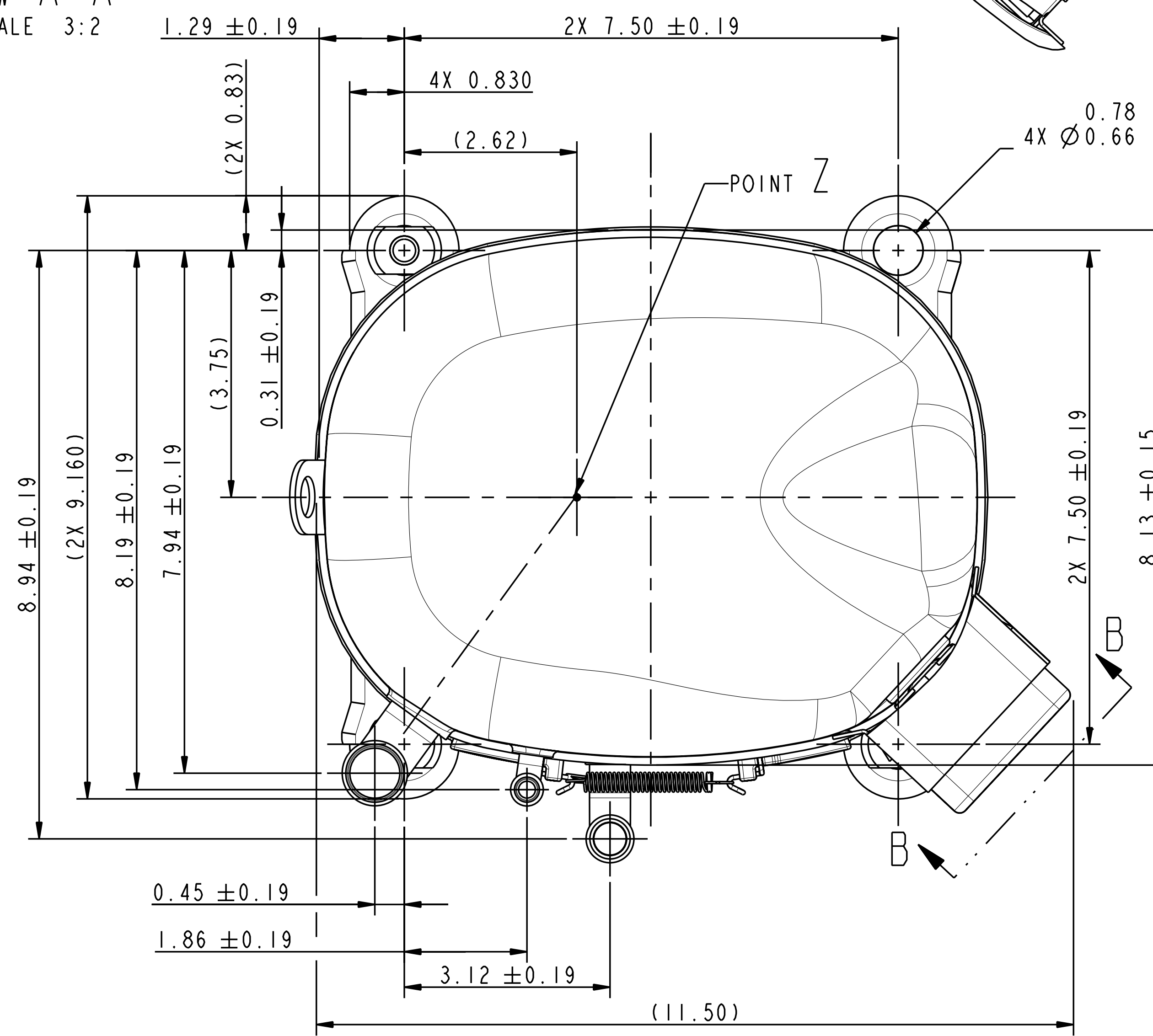
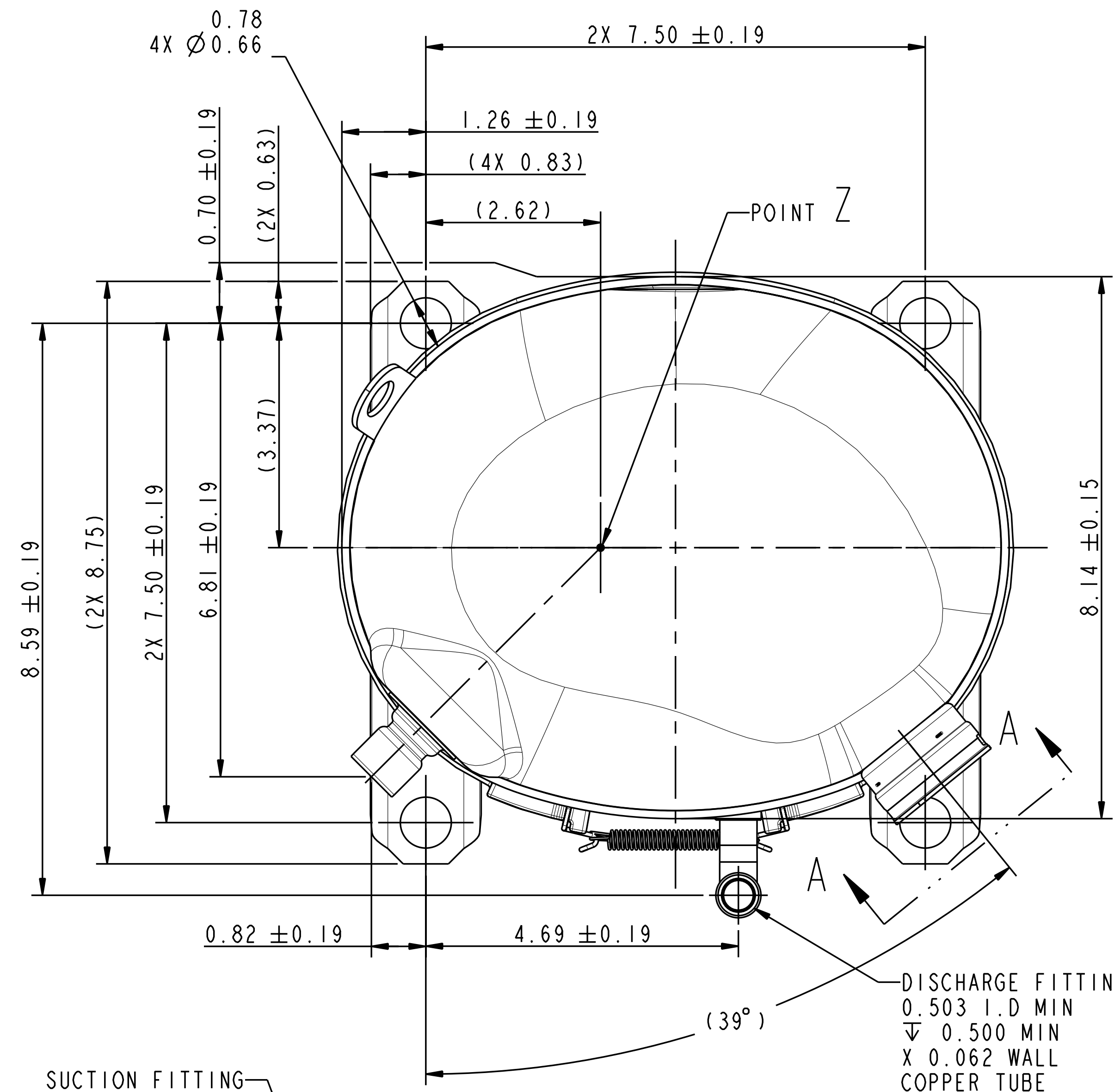
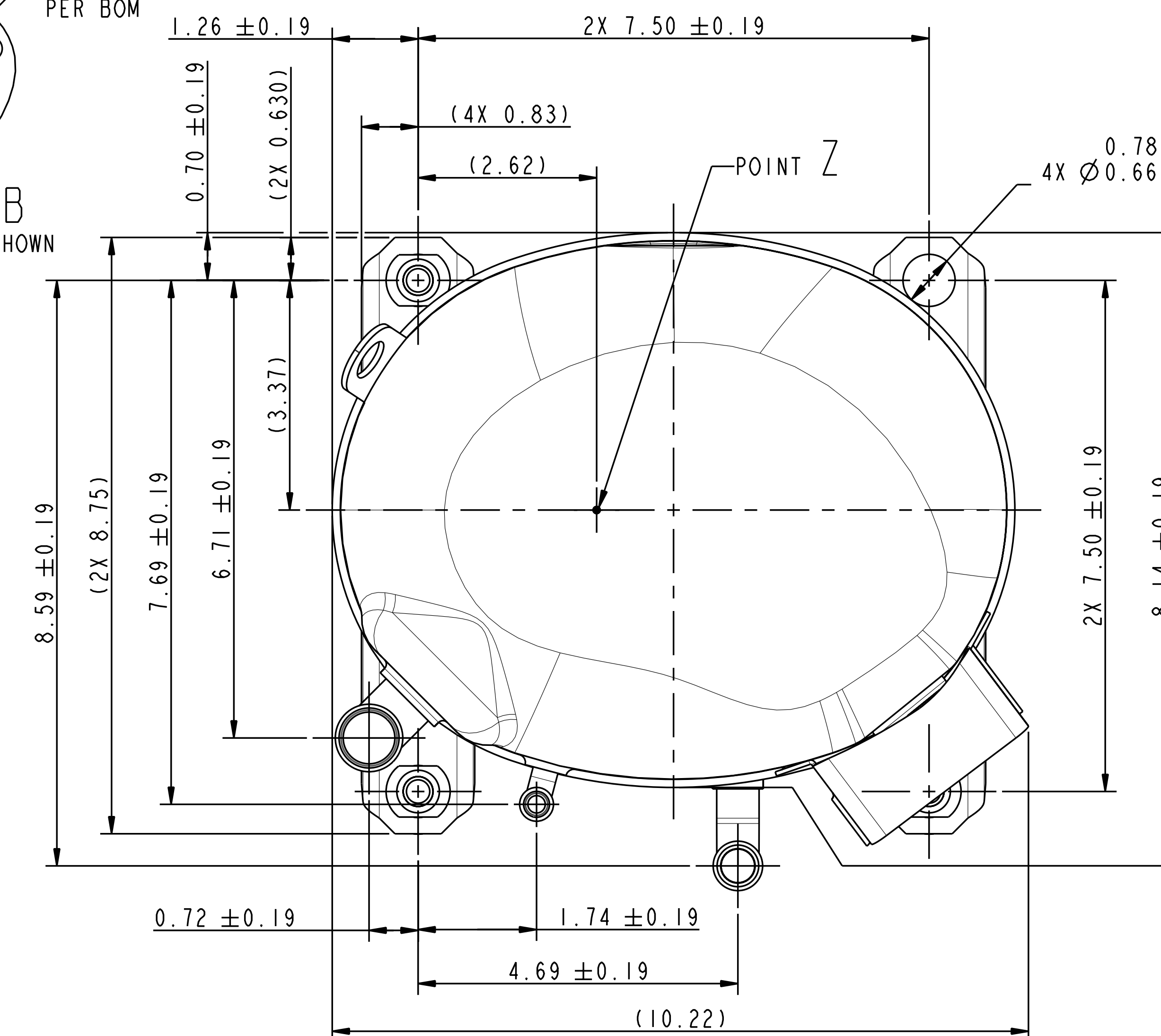
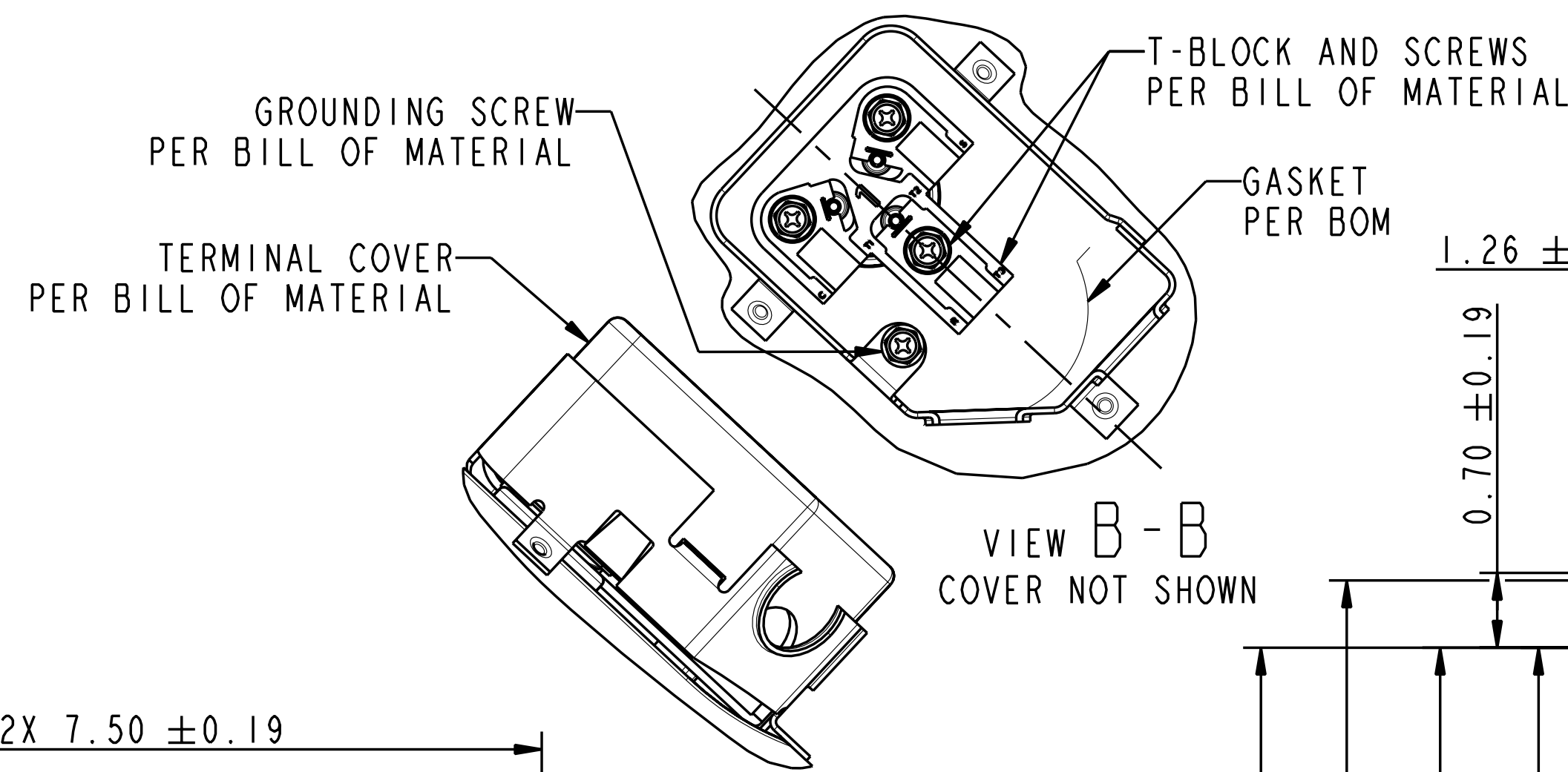
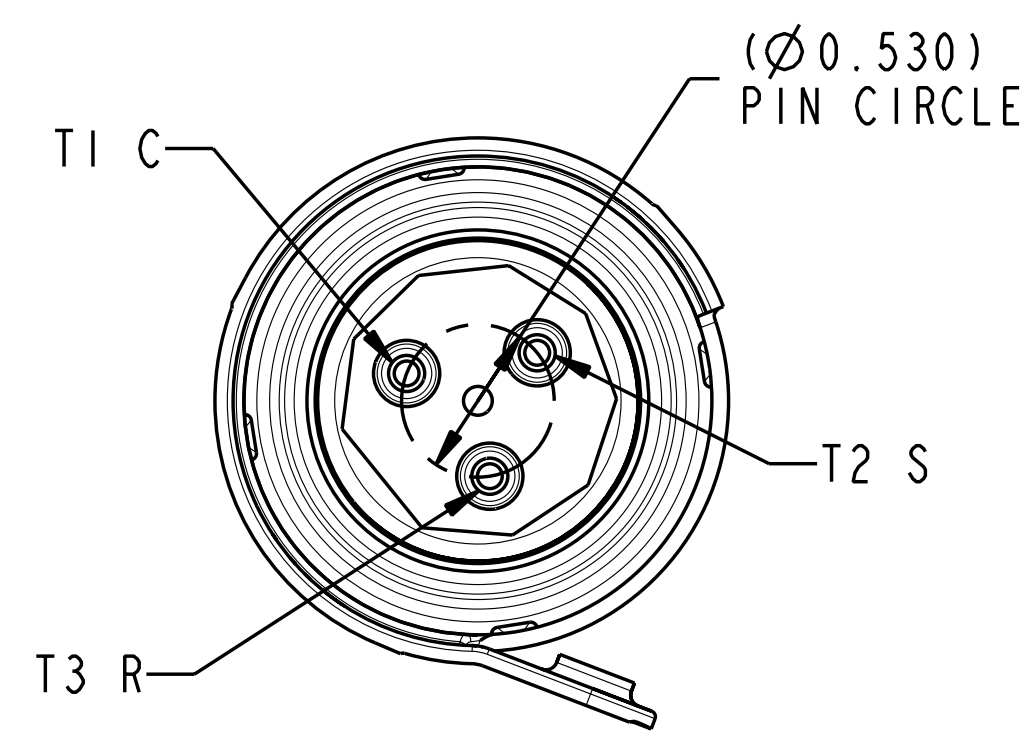
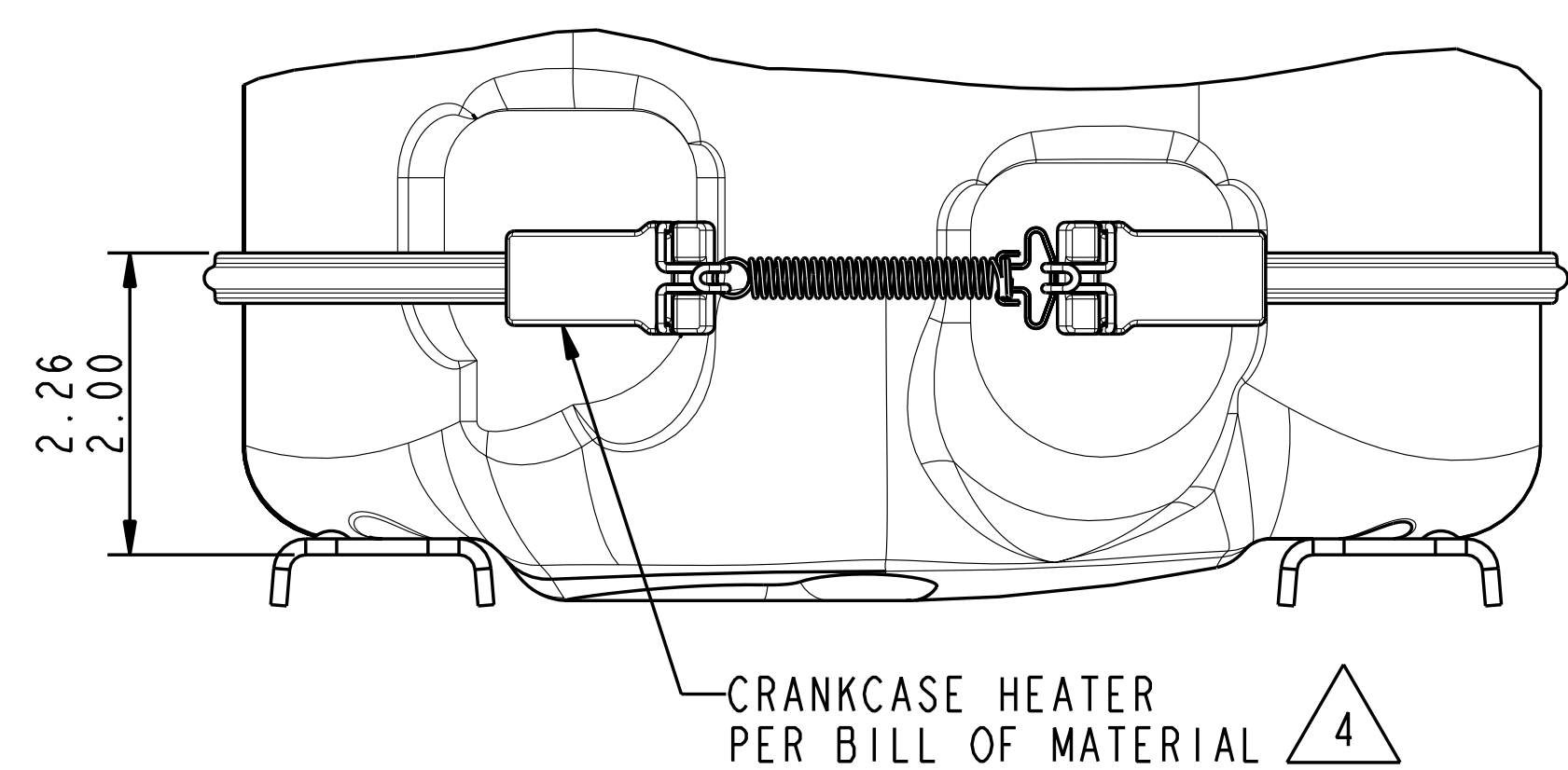

INTERPRET PER ASME Y14.5M-1994 AND EMERSON CLIMATE TECHNOLOGIES, INC. DESIGN STANDARDS DS2002 DO NOT SCALE DRAWING

CRITICAL PRODUCT CHARACTERISTIC

THIRD ANGLE PROJECTION

TOLERANCES:
2-PLACE ± N/A
3-PLACE ± N/A
ANGULAR ± N/A

ECN008047	2	UPDATED MODEL NUMBER	02-10-14	VSB	BAH	EJT
ECN008047	1	ADDED -879 & -979 MODELS	01-30-14	VSB	BAH	EJT
ECN005189	0	RELEASED	03-07-12	PAS	BAH	EJT
ENG NOTICE NO.	REV. NO.	REVISIONS	DATE	BY	CHKD	APPR
3		THIS DRAWING AND INFORMATION CONTAINED HEREIN ARE THE EXCLUSIVE PROPERTY OF EMERSON CLIMATE TECHNOLOGIES, INC. AND SHALL BE RETURNED UPON DEMAND AND SHALL NOT BE REPRODUCED IN WHOLE OR IN PART, DISCLOSED TO ANYONE ELSE OR USED, WITHOUT THE WRITTEN CONSENT OF EMERSON CLIMATE TECHNOLOGIES, INC.				
MATERIAL SPECIFICATION		SUPERSEDES DWG. NO. / REV. NO.				
N/A		PAS				
		DATE		SCALE		
		03-07-12		3:4		
		DATE		MM-DD-YY		
TITLE		DRAWING NUMBER		SHEET		
REF - COMPRESSOR DWG		497-1352-00		2 OF 2		
				5		
				SIZE		