

MODEL NUMBER

- ③ ② ZP57K5E-PFV/TFD/TFE/TF5/TF7
- ③ ① ZP61K5E-PFV/TFD/TF5/TFE/TF7

SPECIFICATIONS

| ES NO.   | DESCRIPTION       |
|----------|-------------------|
| ES92-155 | CONVERSION-METRIC |

NOTES:

- ① ALL TOLERANCES  $\pm 1.50$  [0.060] UNLESS OTHERWISE SPECIFIED.
- ② THE SUCTION TUBE, DISCHARGE TUBE, AND CIRCLE FENCE RADIAL DIMENSIONS ARE TO BE GAUGED FROM THE CENTER OF THE MOUNTING HOLE PATTERN.
3. TUBE ENDS MUST BE PLUGGED.
4. MOUNTING KIT:

| GROMMET DUROMETER | 4 FOOT KIT  |
|-------------------|-------------|
| 35-45             | 527-0116-00 |

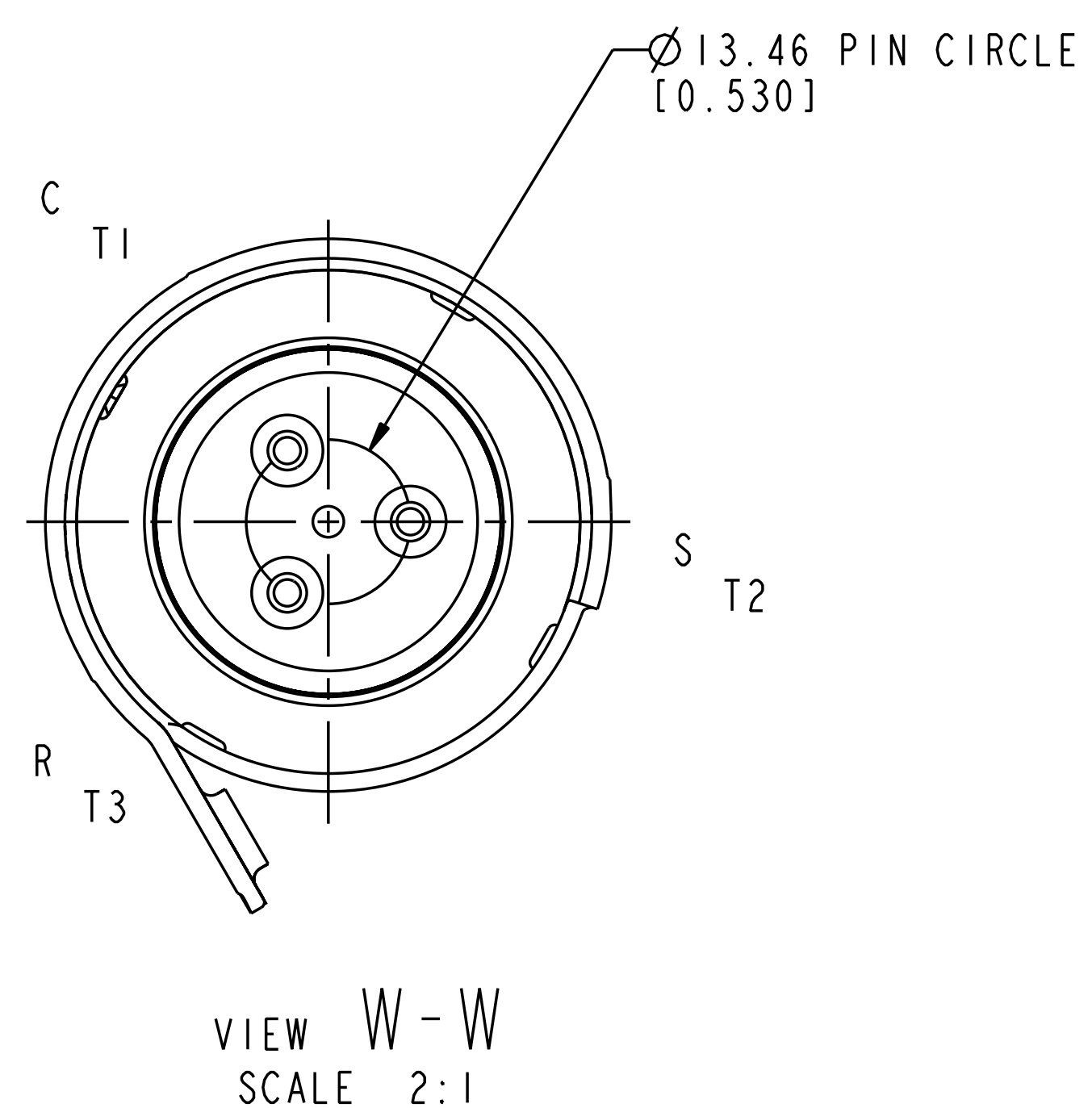
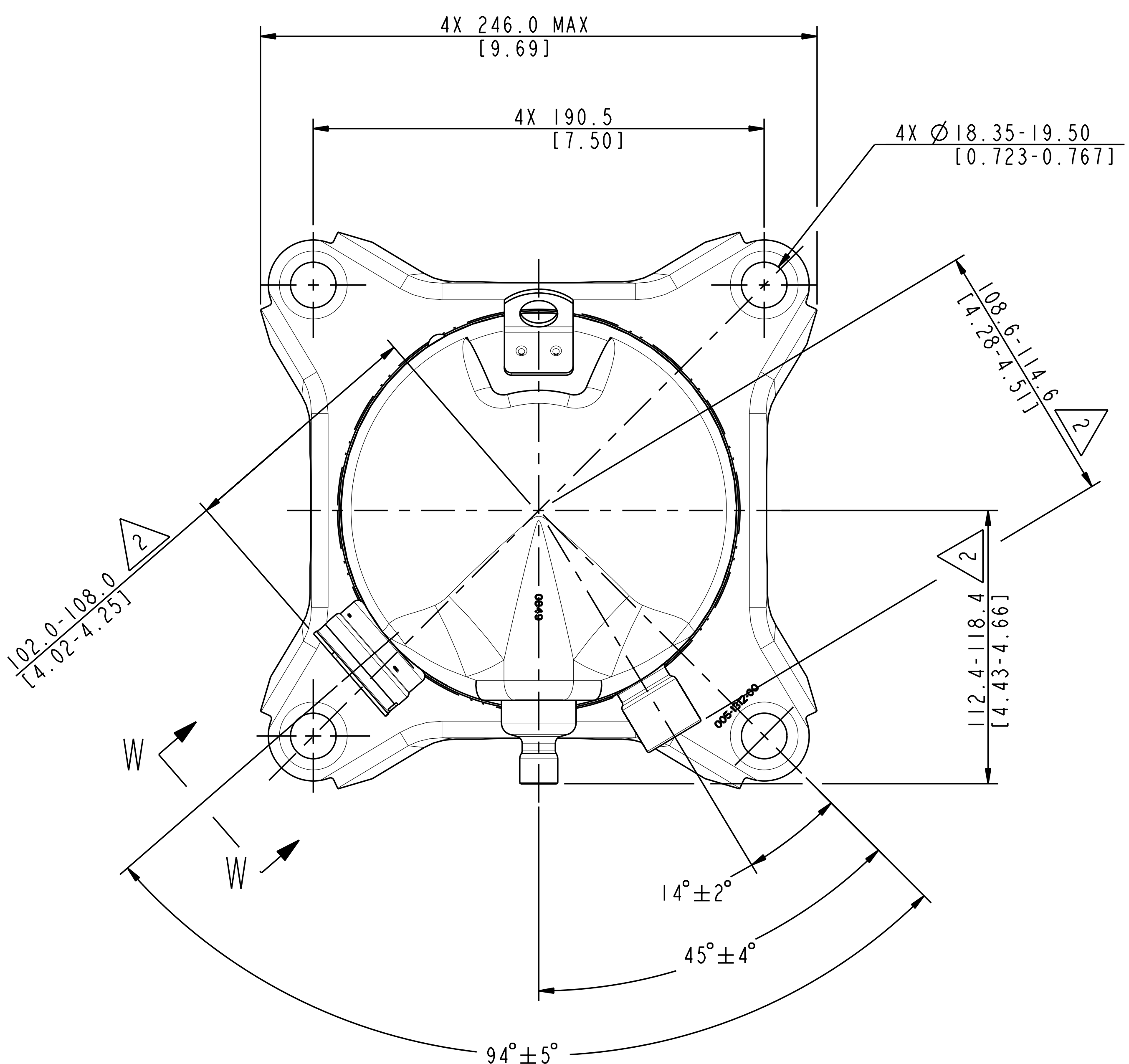
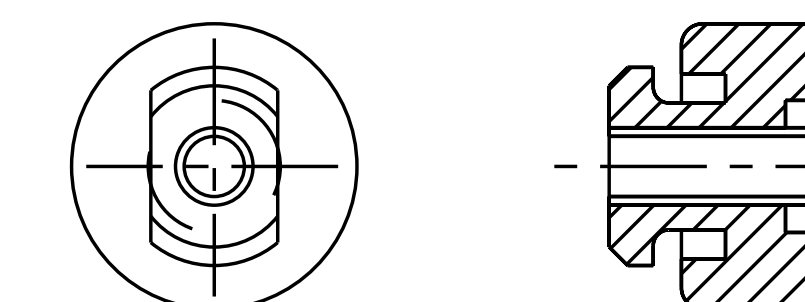

12.78-12.95 I.D. ♦  
[0.504-0.509]  
▽ 10.10 [0.398] MIN,  
0.038 [0.0015] MIN THICK EXTERIOR AND  
0.038 [0.0015] MIN THICK INTERIOR  
COPPER PLATED STEEL DISCHARGE FITTING.

22.30-22.48 I.D. ♦  
[0.878-0.885]  
▽ 20.4 [0.803] MIN,  
0.038 [0.0015] MIN THICK EXTERIOR AND  
0.038 [0.0015] MIN THICK INTERIOR  
COPPER PLATED STEEL SUCTION FITTING

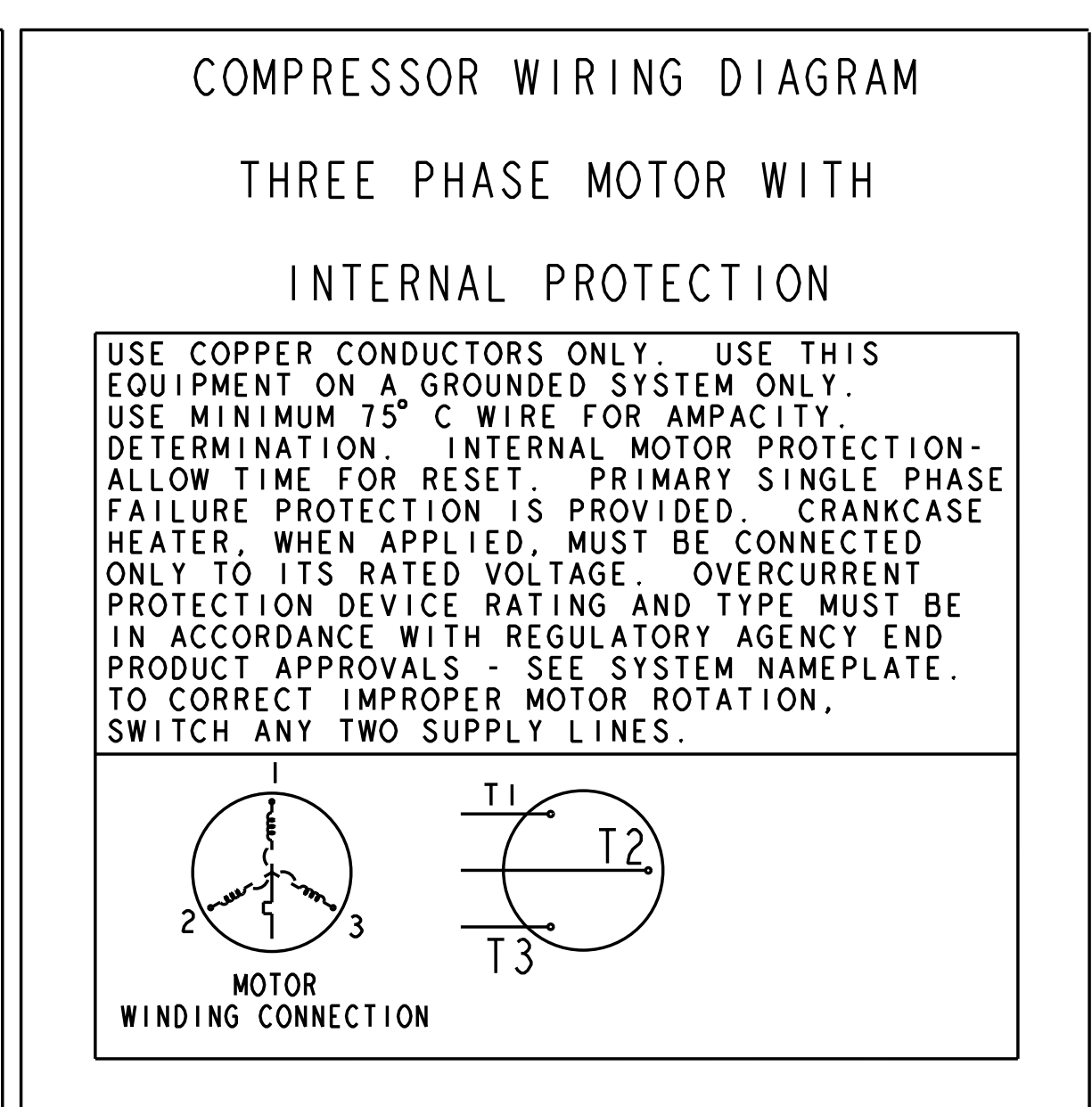
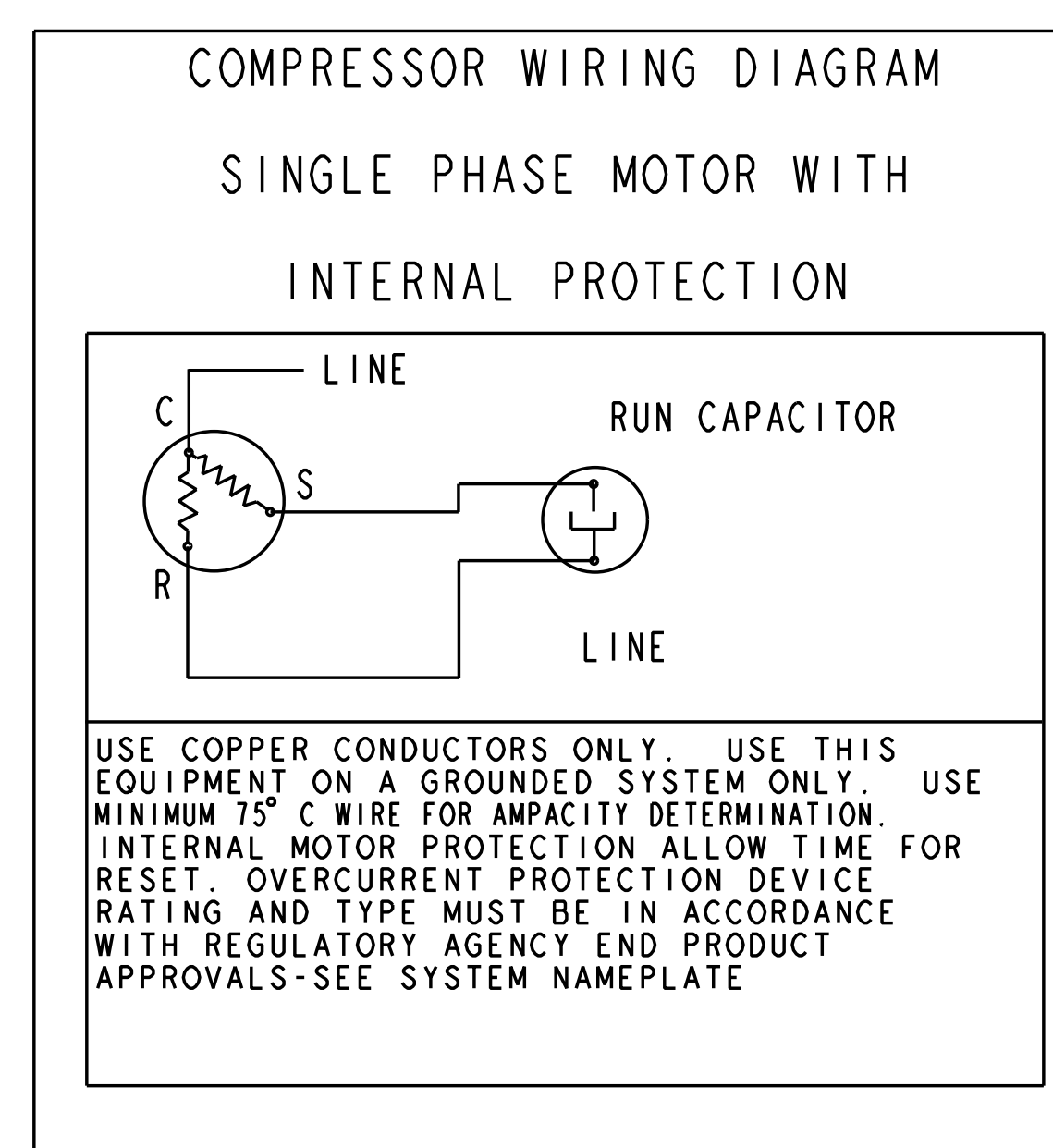
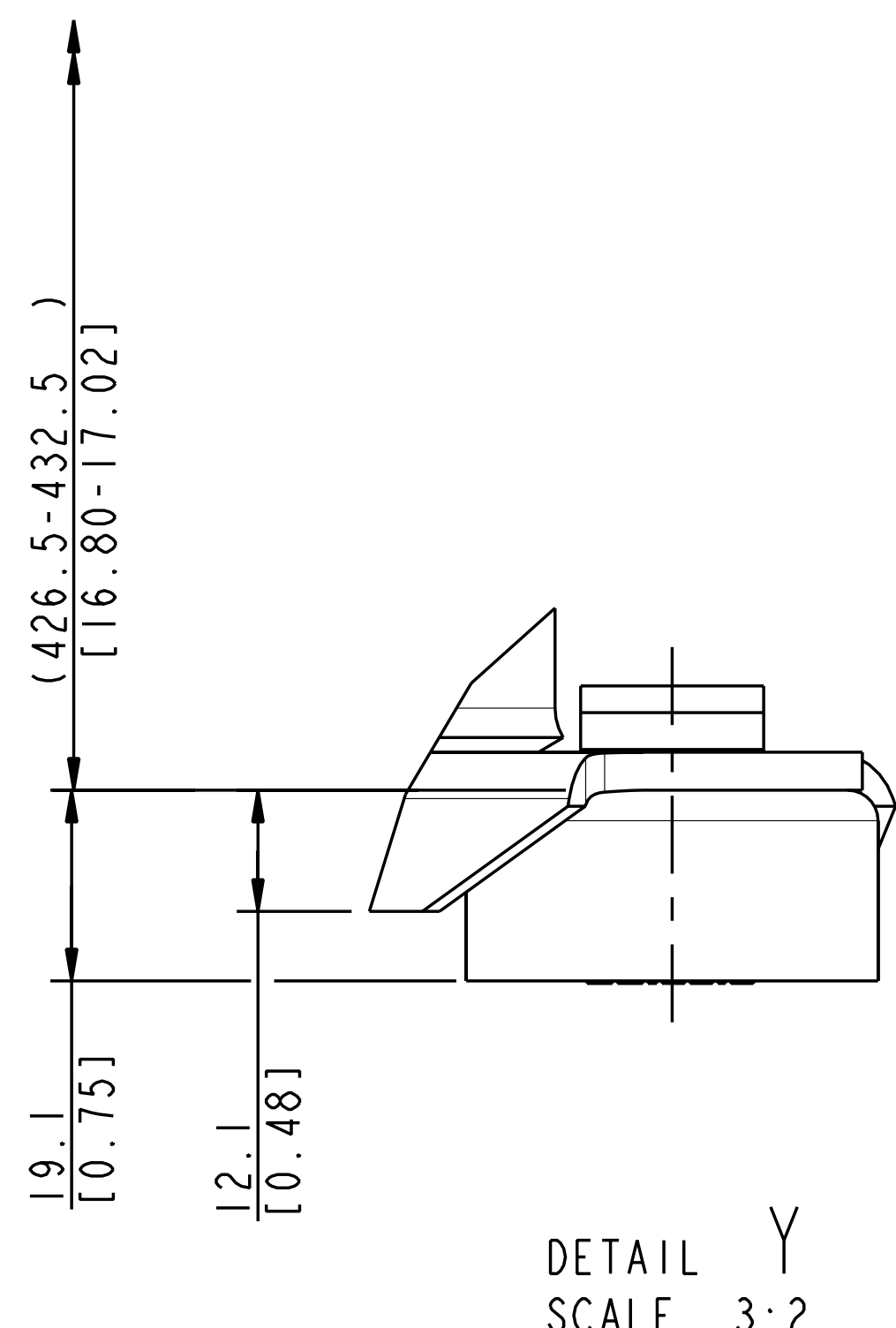
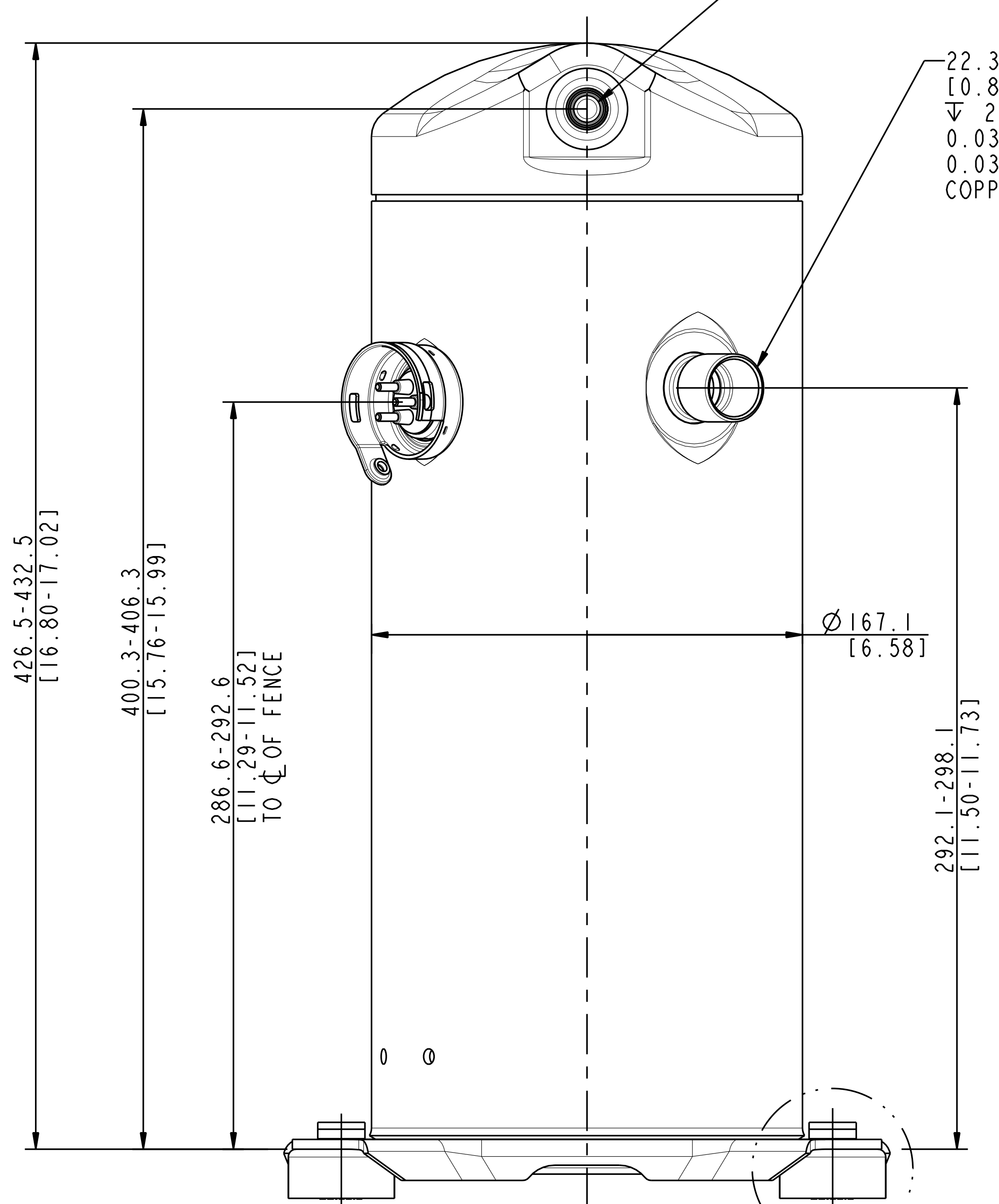

INTERPRET PER ASME Y14.5M-1994 AND EMERSON CLIMATE TECHNOLOGIES, INC. DESIGN STANDARDS DS2002 DO NOT SCALE DRAWING

THIRD ANGLE PROJECTION

CRITICAL PRODUCT CHARACTERISTIC

UNLESS OTHERWISE SPECIFIED DIMENSIONS ARE MILLIMETER OR (INCH)

TOLERANCES:  
1-PLACE  $\pm 1$   
2-PLACE  $\pm N/A$   
ANGULAR  $\pm N/A$

| ENG NOTICE NO. | REV. NO. | REVISIONS                        | DATE     | BY  | CHKD | APPR |
|----------------|----------|----------------------------------|----------|-----|------|------|
| ECN004795      | 3        | ADDED MODELS ZP57/61K5E-TF7      | 05-15-12 | PBM | BR   | KJR  |
| ECN002307      | 2        | ADDED MODELS ZP57K5E-TFD/TFE/TF5 | 06-28-11 | PBM | BR   | KJR  |
| ECN001877      | 1        | ADDED MODELS ZP61K5E-TFD/TFE/TF5 | 03-31-11 | PBM | BR   | KJR  |
| ECN001877      | 0        | RELEASED                         | 09-20-10 | PBM | BR   | KJR  |

24 THIS DRAWING AND INFORMATION CONTAINED HEREIN ARE THE EXCLUSIVE PROPERTY OF EMERSON CLIMATE TECHNOLOGIES, INC. AND SHALL BE RETURNED UPON DEMAND AND SHALL NOT BE REPRODUCED IN WHOLE OR IN PART, DISCLOSED TO ANYONE ELSE OR USED, WITHOUT THE WRITTEN CONSENT OF EMERSON CLIMATE TECHNOLOGIES, INC.

MATERIAL SPECIFICATION: N/A

DRAWN BY: PBM  
DATE: 09-20-10  
SUPERSEDES DWG. NO. / REV. NO.: G021-497-A016-00 / 0  
SCALE: 3:4  
DATE FORMAT: MM-DD-YY

TITLE: REF DWG-WELD COMP ASSM  
DRAWING NUMBER: 497-1000-00  
SHEET 1 OF 1  
DWG SIZE: 5