

OUTDOOR UNIT

Revision A:

• MXZ-3C24NA, MXZ-3C30NA and MXZ-4C36NA have been added.

Please void OBH702.

SERVICE MANUAL



**No. OBH702
REVISED EDITION-A**

Models

**MXZ-3C24NA
MXZ-3C30NA
MXZ-4C36NA
MXZ-5C42NA
MXZ-2C20NAHZ
MXZ-3C24NAHZ
MXZ-3C30NAHZ**

Indoor unit service manual
MSZ-FE·NA Series (OBH542)
MSZ-GE·NA Series (OBH548)
MFZ-KA·NA Series (OBH568)
SEZ-KD·NA Series
PLA-A·BA Series (OCH420)
PCA-A·KA Series (OCH455)
PEAD-A·AA Series
SLZ-KA·NA Series (OCH487)
MSZ-FH·NA Series (OBH683)
MVZ-A·AA Series

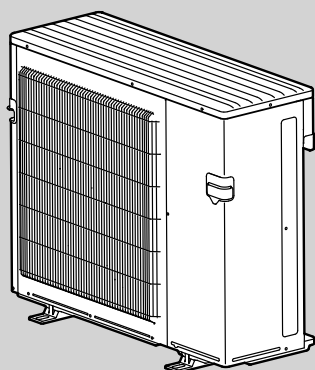

MXZ-3C24NA
MXZ-3C30NA
MXZ-4C36NA

CONTENTS

1. TECHNICAL CHANGES	2
2. PART NAMES AND FUNCTIONS.....	3
3. SPECIFICATION.....	4
4. NOISE CRITERIA CURVES.....	11
5. OUTLINES AND DIMENSIONS	13
6. WIRING DIAGRAM.....	18
7. REFRIGERANT SYSTEM DIAGRAM	23
8. DATA.....	34
9. ACTUATOR CONTROL.....	56
10. SERVICE FUNCTIONS.....	57
11. TROUBLESHOOTING	59
12. DISASSEMBLY INSTRUCTIONS.....	77

INDOOR UNITS COMBINATION TABLES

PARTS CATALOG (OBB702)

Revision A:

• MXZ-3C24NA, MXZ-3C30NA and MXZ-4C36NA have been added.

Use the specified refrigerant only**Never use any refrigerant other than that specified.**

Doing so may cause a burst, an explosion, or fire when the unit is being used, serviced, or disposed of.

Correct refrigerant is specified in the manuals and on the spec labels provided with our products.

We will not be held responsible for mechanical failure, system malfunction, unit breakdown or accidents caused by failure to follow the instructions.

1**TECHNICAL CHANGES****MXZ-5C42NA****MXZ-2C20NAHZ****MXZ-3C24NAHZ****MXZ-3C30NAHZ**

1. New model

MXZ-3C24NA**MXZ-3C30NA****MXZ-4C36NA**

1. New model

MXZ-3C24NA
MXZ-3C30NA
MXZ-4C36NA

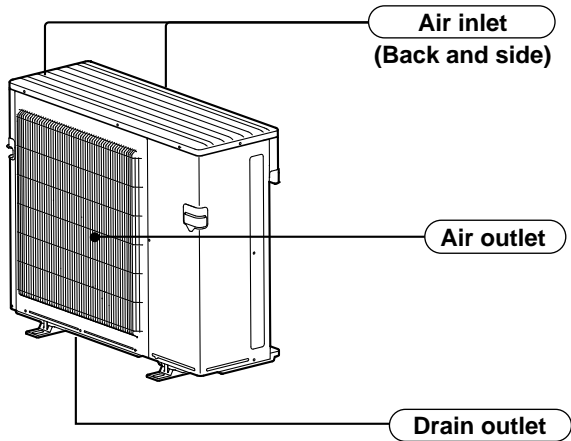

MXZ-5C42NA
MXZ-2C20NAHZ
MXZ-3C24NAHZ
MXZ-3C30NAHZ

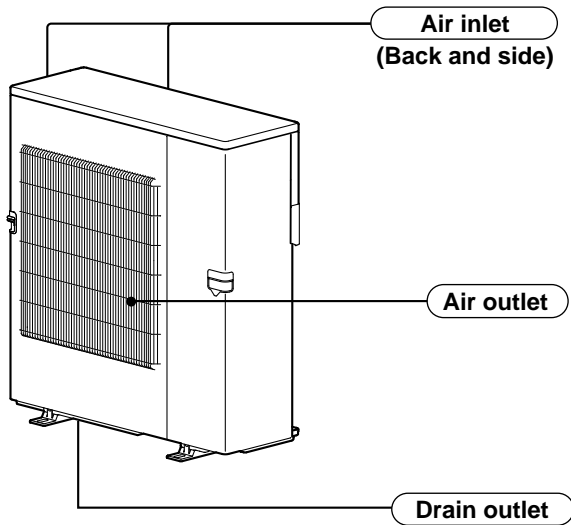

Item		Outdoor model		MXZ-3C24NA	
		Indoor type		Non-Duct (06+09+09)	Duct (09+09+09)
Capacity	Cooling *1	Btu/h	22,000	23,600	
	Heating 47 *1	Btu/h	25,000	24,600	
	Heating 17 *2	Btu/h	19,600	19,600	
Power consumption	Cooling *1	W	1,620	2,100	
	Heating 47 *1	W	1,750	1,900	
	Heating 17 *2	W	2,120	2,230	
EER	Cooling		13.6	11.2	
SEER	Cooling		20.0	16.0	
HSPF IV(V)	Heating		9.8	9.2	
COP	Heating		4.20	3.80	
External finish		Munsell 3.0Y 7.8/1.1			
Power supply		V, phase, Hz	208/230, 1, 60		
Max. fuse size (time delay)		A	25		
Min. circuit ampacity		A	22.1		
Fan motor		F.L.A	1.9		
Compressor	Model	SNB220FQGMC			
	Winding resistance (at 68 °F)	Ω	U-V 0.95 V-W 0.95 W-U 0.95		
		R.L.A	12		
		L.R.A	13.7		
Refrigerant control		LEV			
Sound level		dB(A)	51/55		
Defrost method		Reverse cycle			
Dimensions	W	in.	37-13/32		
	D	in.	13		
	H	in.	31-11/32		
Weight		lb.	135		
Remote controller		Wireless type			
Control voltage (by built-in transformer)		4			
Refrigerant piping		Not supplied (optional parts)			
Valve size	Liquid	in.	1/4		
	Gas	in.	A:1/2 B,C:3/8		
Connection method	Indoor	Flared			
	Outdoor	Flared			
Refrigerant charge (R410A)		lb.	6lb. 13oz.		
Refrigeration oil (Model)		oz.	24.7 (FV50S)		

NOTE : Test conditions are based on ARI 210/240.

Unit: °F

Mode	Test	Indoor air condition		Outdoor air condition	
		Dry bulb	Wet bulb	Dry bulb	Wet bulb
Cooling	*1: "A" Cooling steady state at rated compressor speed	80	67	95	(75)
	"B-2" Cooling steady state at rated compressor speed	80	67	82	(65)
	"B-1" Cooling steady state at minimum compressor speed	80	67	82	(65)
	Low ambient cooling steady state at minimum compressor speed	80	67	67	(53.5)
	Intermediate cooling steady state at intermediate compressor speed	80	67	87	(69)
Heating	*1: Standard rating-heating at rated compressor speed	70	60	47	43
	*2: Low temperature heating at maximum compressor speed	70	60	17	15
	Maximum temperature heating at minimum compressor speed	70	60	62	56.5
	High temperature heating at minimum compressor speed	70	60	47	43
	Frost accumulation at rated compressor speed	70	60	35	33
	Frost accumulation at intermediate compressor speed	70	60	35	33



Item		Outdoor model		MXZ-3C30NA	
		Indoor type		Non-Duct (09+09+12)	Duct (09+09+12)
Capacity	Cooling *1	Btu/h	28,400	27,400	
	Heating 47 *1	Btu/h	28,600	27,600	
	Heating 17 *2	Btu/h	21,000	21,000	
Power consumption	Cooling *1	W	2,680	2,860	
	Heating 47 *1	W	2,150	2,220	
	Heating 17 *2	W	2,120	2,140	
EER	Cooling		10.6	9.6	
SEER	Cooling		19.0	16.2	
HSPF IV(V)	Heating		10.6	10.6	
COP	Heating		3.90	3.64	
External finish		Munsell 3.0Y 7.8/1.1			
Power supply		V, phase, Hz	208/230, 1, 60		
Max. fuse size (time delay)		A	25		
Min. circuit ampacity		A	22.1		
Fan motor		F.L.A	1.9		
Compressor	Model		SNB220FQGM C		
	Winding resistance (at 68 °F)		Ω	U-V 0.95 V-W 0.95 W-U 0.95	
			R.L.A	12	
			L.R.A	13.7	
Refrigerant control			LEV		
Sound level		dB(A)	52/56		
Defrost method			Reverse cycle		
Dimensions	W	in.	37-13/32		
	D	in.	13		
	H	in.	31-11/32		
Weight		lb.	135		
Remote controller			Wireless type		
Control voltage (by built-in transformer)			4		
Refrigerant piping			Not supplied (optional parts)		
Valve size	Liquid	in.	1/4		
	Gas	in.	A:1/2 B,C:3/8		
Connection method	Indoor		Flared		
	Outdoor		Flared		
Refrigerant charge (R410A)		lb.	6lb. 13oz.		
Refrigeration oil (Model)		oz.	24.7 (FV50S)		

NOTE : Test conditions are based on ARI 210/240.

Unit: °F

Mode	Test	Indoor air condition		Outdoor air condition	
		Dry bulb	Wet bulb	Dry bulb	Wet bulb
Cooling	*1: "A" Cooling steady state at rated compressor speed	80	67	95	(75)
	"B-2" Cooling steady state at rated compressor speed	80	67	82	(65)
	"B-1" Cooling steady state at minimum compressor speed	80	67	82	(65)
	Low ambient cooling steady state at minimum compressor speed	80	67	67	(53.5)
	Intermediate cooling steady state at intermediate compressor speed	80	67	87	(69)
Heating	*1: Standard rating-heating at rated compressor speed	70	60	47	43
	*2: Low temperature heating at maximum compressor speed	70	60	17	15
	Maximum temperature heating at minimum compressor speed	70	60	62	56.5
	High temperature heating at minimum compressor speed	70	60	47	43
	Frost accumulation at rated compressor speed	70	60	35	33
	Frost accumulation at intermediate compressor speed	70	60	35	33



Item		Outdoor model		MXZ-4C36NA	
		Indoor type		Non-Duct (09+09+09+09)	Duct (09+09+09+09)
Capacity	Cooling *1	Btu/h	35,400	34,400	
	Heating 47 *1	Btu/h	36,000	34,400	
	Heating 17 *2	Btu/h	26,600	26,600	
Power consumption	Cooling *1	W	3,760	3,940	
	Heating 47 *1	W	3,020	3,100	
	Heating 17 *2	W	3,340	3,450	
EER	Cooling		9.4	8.7	
SEER	Cooling		19.2	16.0	
HSPF IV(V)	Heating		11.0	9.8	
COP	Heating		3.50	3.25	
External finish		Munsell 3.0Y 7.8/1.1			
Power supply		V, phase, Hz	208/230, 1, 60		
Max. fuse size (time delay)		A	25		
Min. circuit ampacity		A	22.1		
Fan motor		F.L.A	1.9		
Compressor	Model	SNB220FQGMC			
	Winding resistance (at 68 °F)	Ω	U-V 0.95 V-W 0.95 W-U 0.95		
		R.L.A	12		
		L.R.A	13.7		
Refrigerant control			LEV		
Sound level		dB(A)	54/56		
Defrost method			Reverse cycle		
Dimensions	W	in.	37-13/32		
	D	in.	13		
	H	in.	31-11/32		
Weight		lb.	137		
Remote controller			Wireless type		
Control voltage (by built-in transformer)			4		
Refrigerant piping			Not supplied (optional parts)		
Valve size	Liquid	in.	1/4		
	Gas	in.	A:1/2 B,C,D:3/8		
Connection method	Indoor		Flared		
	Outdoor		Flared		
Refrigerant charge (R410A)		lb.	6lb. 13oz.		
Refrigeration oil (Model)		oz.	24.7 (FV50S)		

NOTE : Test conditions are based on ARI 210/240.

Unit: °F

Mode	Test	Indoor air condition		Outdoor air condition	
		Dry bulb	Wet bulb	Dry bulb	Wet bulb
Cooling	*1: "A" Cooling steady state at rated compressor speed	80	67	95	(75)
	"B-2" Cooling steady state at rated compressor speed	80	67	82	(65)
	"B-1" Cooling steady state at minimum compressor speed	80	67	82	(65)
	Low ambient cooling steady state at minimum compressor speed	80	67	67	(53.5)
	Intermediate cooling steady state at intermediate compressor speed	80	67	87	(69)
Heating	*1: Standard rating-heating at rated compressor speed	70	60	47	43
	*2: Low temperature heating at maximum compressor speed	70	60	17	15
	Maximum temperature heating at minimum compressor speed	70	60	62	56.5
	High temperature heating at minimum compressor speed	70	60	47	43
	Frost accumulation at rated compressor speed	70	60	35	33
	Frost accumulation at intermediate compressor speed	70	60	35	33



Item		Outdoor model		MXZ-5C42NA	
		Indoor type	Non-Duct (06+09+09+09+09)	Duct (09+09+09+09+09)	
Capacity	Cooling *1	Btu/h	40,500	37,500	
	Heating 47 *1	Btu/h	45,000	41,000	
	Heating 17 *2	Btu/h	24,400	23,000	
Power consumption	Cooling *1	W	4,403	4,112	
	Heating 47 *1	W	3,575	3,463	
	Heating 17 *2	W	2,943	2,869	
EER	Cooling		9.2	9.0	
SEER	Cooling		19.7	15.2	
HSPF IV(V)	Heating		10.3	9.1	
COP	Heating		3.69	3.47	
External finish		Munsell 3.0Y 7.8/1.1			
Power supply		V, phase, Hz	208/230, 1, 60		
Max. fuse size (time delay)		A	40		
Min. circuit ampacity		A	31.9		
Fan motor		F.L.A	1.9		
Compressor	Model	MNB33FBTMC-L			
	Winding resistance (at 68 °F)	Ω	U-V 0.30 V-W 0.30 W-U 0.30		
		R.L.A	20		
		L.R.A	28.8		
Refrigerant control			LEV		
Sound level		dB(A)	56/58		
Defrost method			Reverse cycle		
Dimensions	W	in.	37-13/32		
	D	in.	13		
	H	in.	41-17/64		
Weight		lb.	189		
Remote controller			Wireless type		
Control voltage (by built-in transformer)			4		
Refrigerant piping			Not supplied (optional parts)		
Valve size	Liquid	in.	1/4		
	Gas	in.	A:1/2 B,C,D,E: 3/8		
Connection method	Indoor		Flared		
	Outdoor		Flared		
Refrigerant charge (R410A)		lb.	8 lb. 13 oz.		
Refrigeration oil (Model)		oz.	37.4 (FV50S)		

NOTE : Test conditions are based on ARI 210/240.

Unit: °F

Mode	Test	Indoor air condition		Outdoor air condition	
		Dry bulb	Wet bulb	Dry bulb	Wet bulb
Cooling	*1: "A" Cooling steady state at rated compressor speed	80	67	95	(75)
	"B-2" Cooling steady state at rated compressor speed	80	67	82	(65)
	"B-1" Cooling steady state at minimum compressor speed	80	67	82	(65)
	Low ambient cooling steady state at minimum compressor speed	80	67	67	(53.5)
	Intermediate cooling steady state at intermediate compressor speed	80	67	87	(69)
Heating	*1: Standard rating-heating at rated compressor speed	70	60	47	43
	*2: Low temperature heating at maximum compressor speed	70	60	17	15
	Maximum temperature heating at minimum compressor speed	70	60	62	56.5
	High temperature heating at minimum compressor speed	70	60	47	43
	Frost accumulation at rated compressor speed	70	60	35	33
	Frost accumulation at intermediate compressor speed	70	60	35	33



Item		Outdoor model		MXZ-2C20NAHZ	
		Indoor type		Non-Duct (09+09)	Duct (09+12)
Capacity	Cooling *1	Btu/h		18,000	20,000
	Heating 47 *1	Btu/h		22,000	22,000
	Heating 17 *2	Btu/h		13,700	13,700
Power consumption	Cooling *1	W		1,334	1,819
	Heating 47 *1	W		1,612	1,748
	Heating 17 *2	W		1,450	1,588
EER	Cooling			13.5	11.0
SEER	Cooling			17.0	15.0
HSPF IV(V)	Heating			9.8	9.5
COP	Heating			4.00	3.69
External finish		Munsell 3.0Y 7.8/1.1			
Power supply		V, phase, Hz		208/230, 1, 60	
Max. fuse size (time delay)		A		40	
Min. circuit ampacity		A		28.9	
Fan motor		F.L.A		1.9	
Compressor	Model		MNB33FBTMC-L		
	Winding resistance (at 68 °F)		Ω	U-V 0.30 V-W 0.30 W-U 0.30	
			R.L.A	20	
			L.R.A	28.8	
Refrigerant control		LEV			
Sound level		dB(A)		54/58	
Defrost method		Reverse cycle			
Dimensions	W	in.		37-13/32	
	D	in.		13	
	H	in.		41-17/64	
Weight		lb.		187	
Remote controller		Wireless type			
Control voltage (by built-in transformer)		4			
Refrigerant piping		Not supplied (optional parts)			
Valve size	Liquid	in.		1/4	
	Gas	in.		A,B: 3/8	
Connection method	Indoor		Flared		
	Outdoor		Flared		
Refrigerant charge (R410A)		lb.		8 lb. 13 oz.	
Refrigeration oil (Model)		oz.		37.4 (FV50S)	

NOTE : Test conditions are based on ARI 210/240.

Unit: °F

Mode	Test	Indoor air condition		Outdoor air condition	
		Dry bulb	Wet bulb	Dry bulb	Wet bulb
Cooling	*1: "A" Cooling steady state at rated compressor speed	80	67	95	(75)
	"B-2" Cooling steady state at rated compressor speed	80	67	82	(65)
	"B-1" Cooling steady state at minimum compressor speed	80	67	82	(65)
	Low ambient cooling steady state at minimum compressor speed	80	67	67	(53.5)
	Intermediate cooling steady state at intermediate compressor speed	80	67	87	(69)
Heating	*1: Standard rating-heating at rated compressor speed	70	60	47	43
	*2: Low temperature heating at maximum compressor speed	70	60	17	15
	Maximum temperature heating at minimum compressor speed	70	60	62	56.5
	High temperature heating at minimum compressor speed	70	60	47	43
	Frost accumulation at rated compressor speed	70	60	35	33
	Frost accumulation at intermediate compressor speed	70	60	35	33



Item		Outdoor model		MXZ-3C24NAHZ	
		Indoor type	Non-Duct (06+06+09)		Duct (09+09+09)
Capacity	Cooling *1	Btu/h	22,000	23,600	
	Heating 47 *1	Btu/h	25,000	24,600	
	Heating 17 *2	Btu/h	14,000	14,000	
Power consumption	Cooling *1	W	1,630	2,360	
	Heating 47 *1	W	1,725	1,871	
	Heating 17 *2	W	1,622	1,635	
EER	Cooling		13.5	10.0	
SEER	Cooling		19.0	15.5	
HSPF IV(V)	Heating		10.0	9.0	
COP	Heating		4.25	3.80	
External finish		Munsell 3.0Y 7.8/1.1			
Power supply		V, phase, Hz	208/230, 1, 60		
Max. fuse size (time delay)		A	40		
Min. circuit ampacity		A	29.9		
Fan motor		F.L.A	1.9		
Compressor	Model	MNB33FBTMC-L			
	Winding resistance (at 68 °F)	Ω	U-V 0.30 V-W 0.30 W-U 0.30		
		R.L.A	20		
		L.R.A	28.8		
Refrigerant control			LEV		
Sound level		dB(A)	54/58		
Defrost method			Reverse cycle		
Dimensions	W	in.	37-13/32		
	D	in.	13		
	H	in.	41-17/64		
Weight		lb.	189		
Remote controller			Wireless type		
Control voltage (by built-in transformer)			4		
Refrigerant piping			Not supplied (optional parts)		
Valve size	Liquid	in.	1/4		
	Gas	in.	A: 1/2 B,C: 3/8		
Connection method	Indoor		Flared		
	Outdoor		Flared		
Refrigerant charge (R410A)		lb.	8 lb. 13 oz.		
Refrigeration oil (Model)		oz.	37.4 (FV50S)		

NOTE : Test conditions are based on ARI 210/240.

Unit: °F

Mode	Test	Indoor air condition		Outdoor air condition	
		Dry bulb	Wet bulb	Dry bulb	Wet bulb
Cooling	*1: "A" Cooling steady state at rated compressor speed	80	67	95	(75)
	"B-2" Cooling steady state at rated compressor speed	80	67	82	(65)
	"B-1" Cooling steady state at minimum compressor speed	80	67	82	(65)
	Low ambient cooling steady state at minimum compressor speed	80	67	67	(53.5)
	Intermediate cooling steady state at intermediate compressor speed	80	67	87	(69)
Heating	*1: Standard rating-heating at rated compressor speed	70	60	47	43
	*2: Low temperature heating at maximum compressor speed	70	60	17	15
	Maximum temperature heating at minimum compressor speed	70	60	62	56.5
	High temperature heating at minimum compressor speed	70	60	47	43
	Frost accumulation at rated compressor speed	70	60	35	33
	Frost accumulation at intermediate compressor speed	70	60	35	33



Item		Outdoor model		MXZ-3C30NAHZ	
		Indoor type		Non-Duct (09+09+12)	Duct (09+09+12)
Capacity	Cooling *1	Btu/h	28,400	27,400	
	Heating 47 *1	Btu/h	28,600	27,600	
	Heating 17 *2	Btu/h	18,000	17,000	
Power consumption	Cooling *1	W	2,272	2,661	
	Heating 47 *1	W	2,096	2,187	
	Heating 17 *2	W	1,991	1,993	
EER	Cooling		12.5	10.3	
SEER	Cooling		18.0	16.0	
HSPF IV(V)	Heating		11.0	9.8	
COP	Heating		4.00	3.70	
External finish		Munsell 3.0Y 7.8/1.1			
Power supply		V, phase, Hz	208/230, 1, 60		
Max. fuse size (time delay)		A	40		
Min. circuit ampacity		A	29.9		
Fan motor		F.L.A	1.9		
Compressor	Model		MNB33FBTMC-L		
	Winding resistance (at 68 °F)		Ω	U-V 0.30 V-W 0.30 W-U 0.30	
			R.L.A	20	
			L.R.A	28.8	
Refrigerant control			LEV		
Sound level		dB(A)	54/58		
Defrost method			Reverse cycle		
Dimensions	W	in.	37-13/32		
	D	in.	13		
	H	in.	41-17/64		
Weight		lb.	189		
Remote controller			Wireless type		
Control voltage (by built-in transformer)			4		
Refrigerant piping			Not supplied (optional parts)		
Valve size	Liquid	in.	1/4		
	Gas	in.	A: 1/2 B,C: 3/8		
Connection method	Indoor		Flared		
	Outdoor		Flared		
Refrigerant charge (R410A)		lb.	8 lb. 13 oz.		
Refrigeration oil (Model)		oz.	37.4 (FV50S)		

NOTE : Test conditions are based on ARI 210/240.

Unit: °F

Mode	Test	Indoor air condition		Outdoor air condition	
		Dry bulb	Wet bulb	Dry bulb	Wet bulb
Cooling	*1: "A" Cooling steady state at rated compressor speed	80	67	95	(75)
	"B-2" Cooling steady state at rated compressor speed	80	67	82	(65)
	"B-1" Cooling steady state at minimum compressor speed	80	67	82	(65)
	Low ambient cooling steady state at minimum compressor speed	80	67	67	(53.5)
	Intermediate cooling steady state at intermediate compressor speed	80	67	87	(69)
Heating	*1: Standard rating-heating at rated compressor speed	70	60	47	43
	*2: Low temperature heating at maximum compressor speed	70	60	17	15
	Maximum temperature heating at minimum compressor speed	70	60	62	56.5
	High temperature heating at minimum compressor speed	70	60	47	43
	Frost accumulation at rated compressor speed	70	60	35	33
	Frost accumulation at intermediate compressor speed	70	60	35	33

4

NOISE CRITERIA CURVES

MXZ-3C24NA

FAN SPEED	FUNCTION	SPL(dB(A))	LINE
High	Cooling	51	●—●
High	Heating	55	○—○

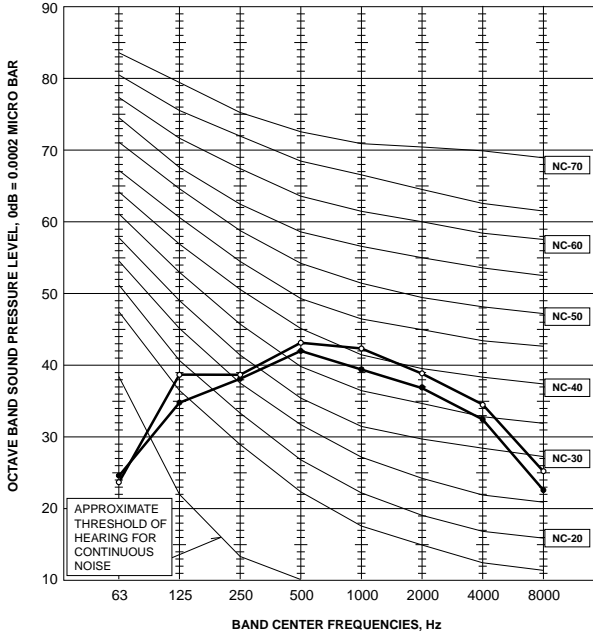

MXZ-3C30NA

FAN SPEED	FUNCTION	SPL(dB(A))	LINE
High	Cooling	52	●—●
High	Heating	56	○—○

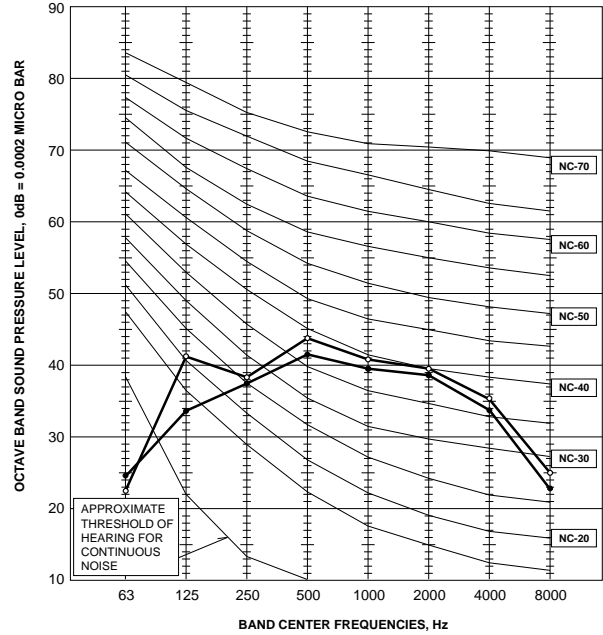

MXZ-4C36NA

FAN SPEED	FUNCTION	SPL(dB(A))	LINE
High	Cooling	54	●—●
High	Heating	56	○—○

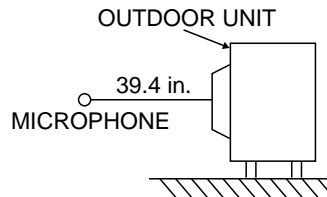
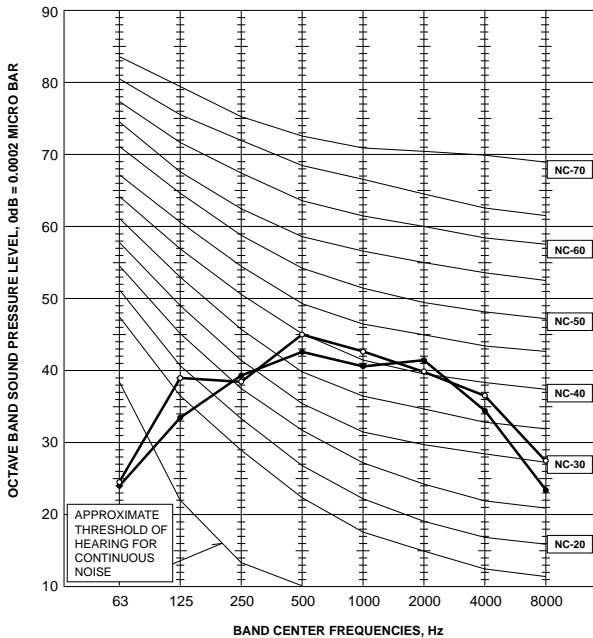

Test conditions

Cooling: Dry-bulb temperature 95°F Wet-bulb temperature 75°F
 Heating: Dry-bulb temperature 45°F Wet-bulb temperature 43°F

MXZ-5C42NA

FAN SPEED	FUNCTION	SPL(dB(A))	LINE
High	Cooling	56	●—●
High	Heating	58	○—○

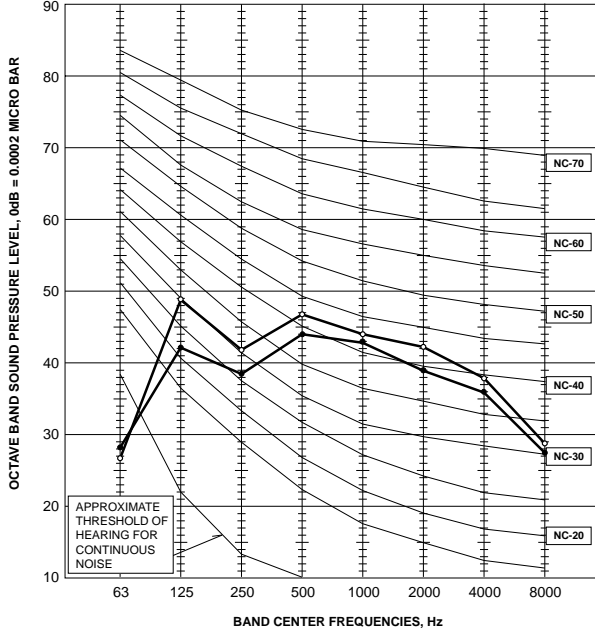

MXZ-2C20NAHZ

FAN SPEED	FUNCTION	SPL(dB(A))	LINE
High	Cooling	54	●—●
High	Heating	58	○—○

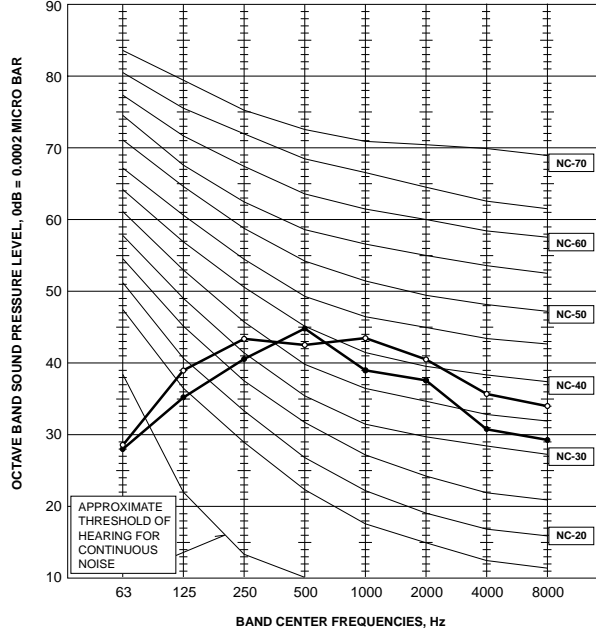

MXZ-3C24NAHZ

FAN SPEED	FUNCTION	SPL(dB(A))	LINE
High	Cooling	54	●—●
High	Heating	58	○—○

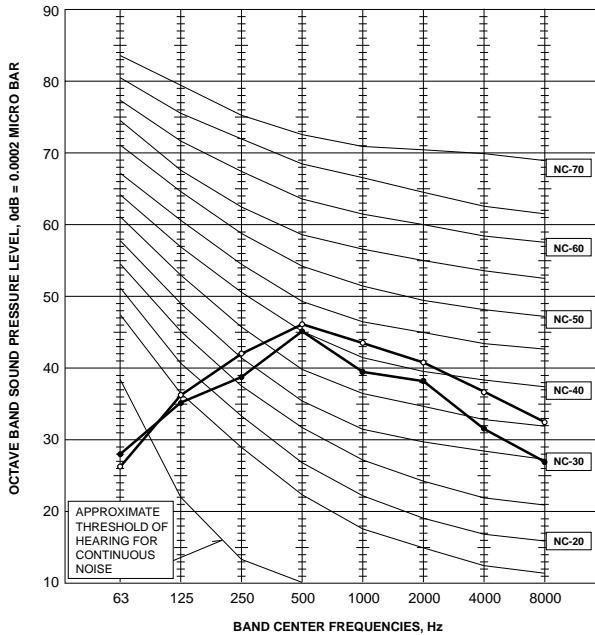

MXZ-3C30NAHZ

FAN SPEED	FUNCTION	SPL(dB(A))	LINE
High	Cooling	54	●—●
High	Heating	58	○—○

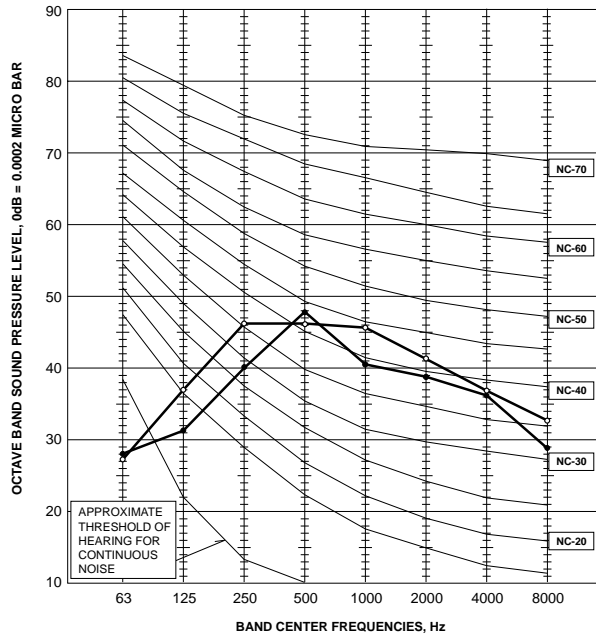

MXZ-5C42NA

Unit: inch (mm)

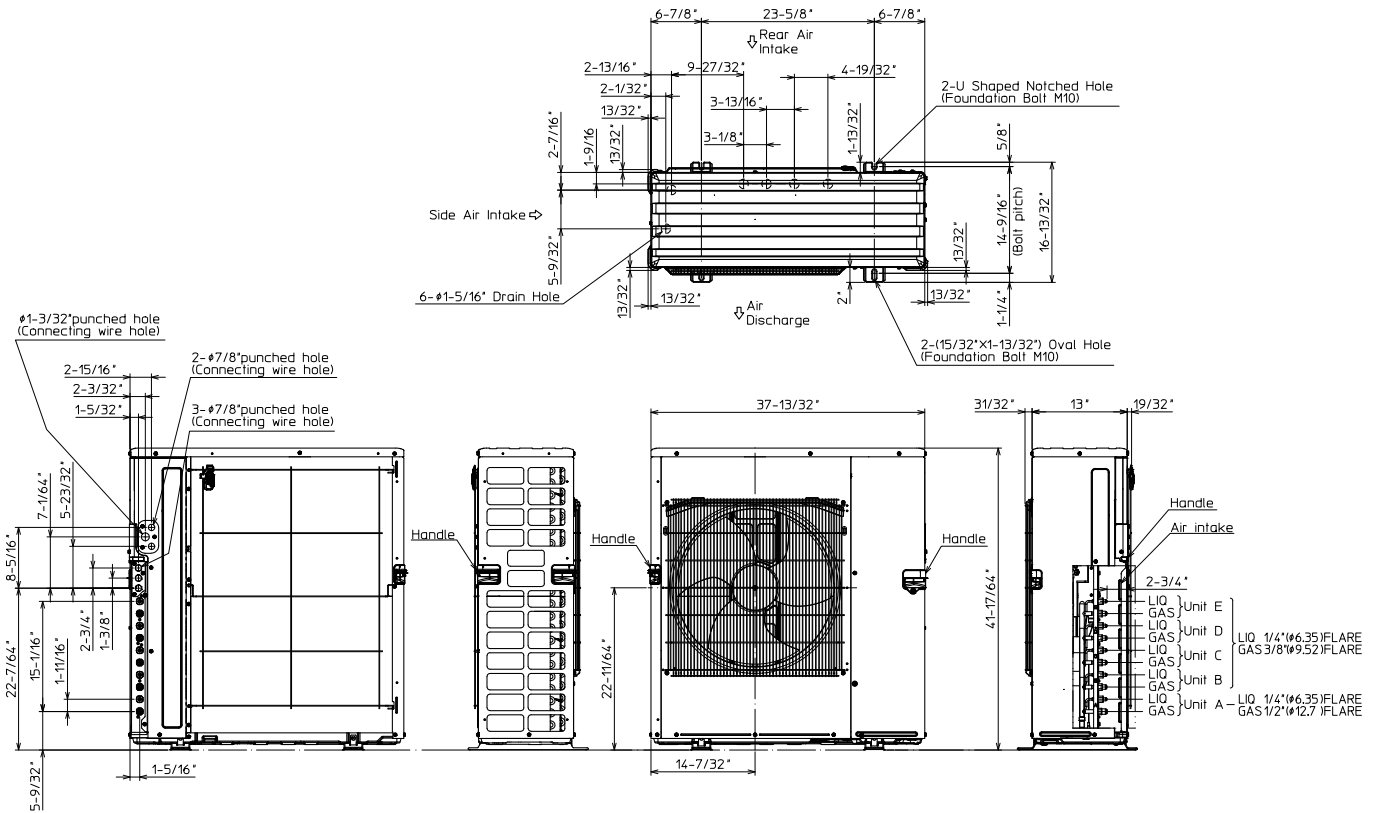

1.FREE SPACE

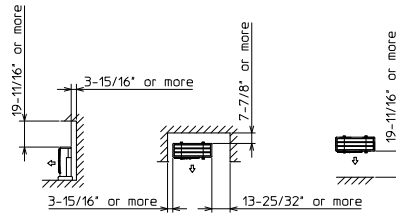

2.SERVICE SPACE

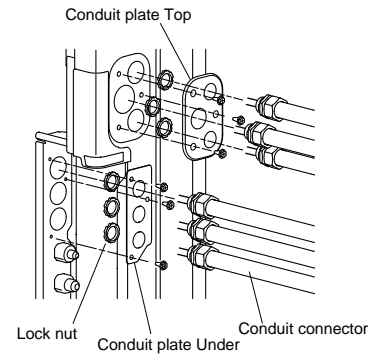
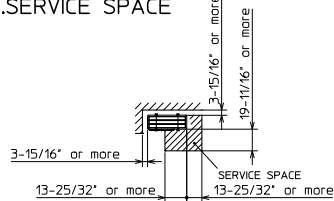

MXZ-2C20NAHZ

Unit: inch (mm)

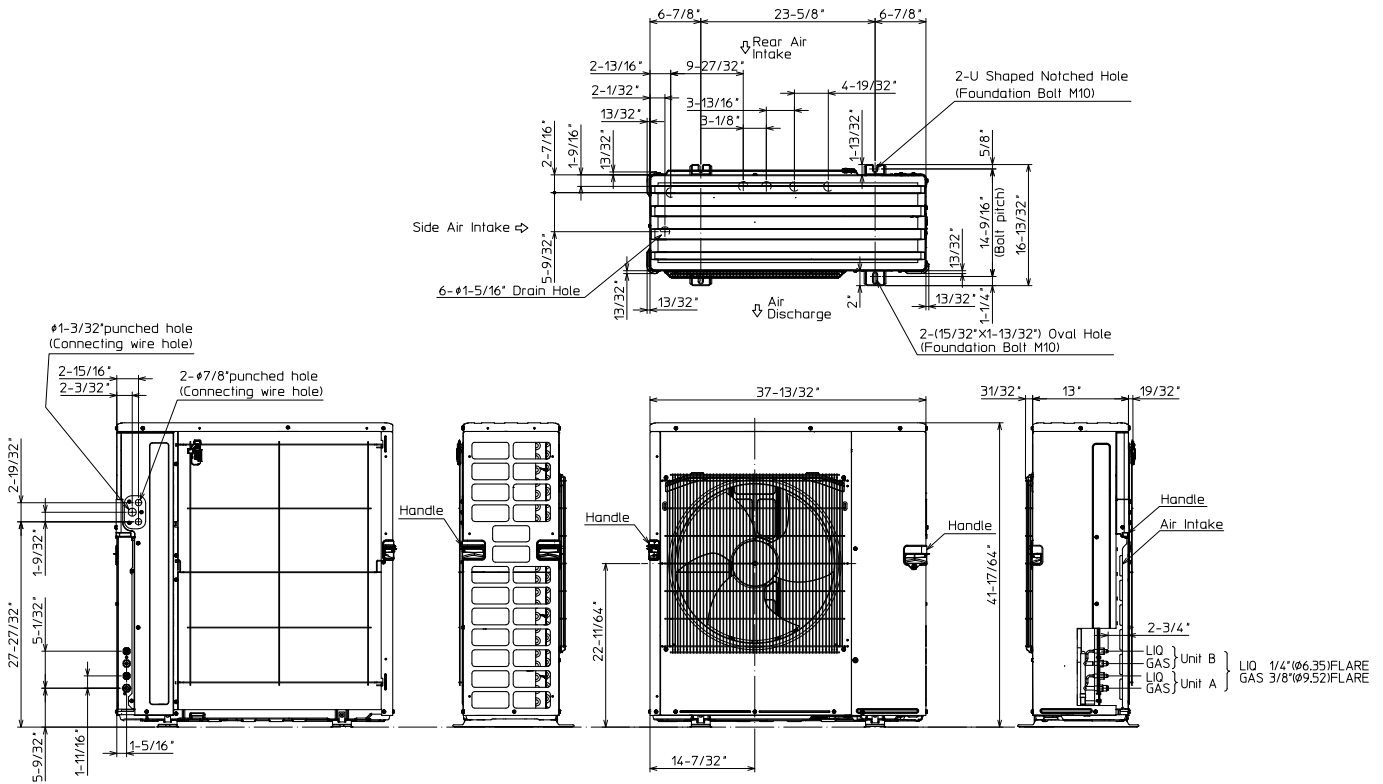

1. FREE SPACE

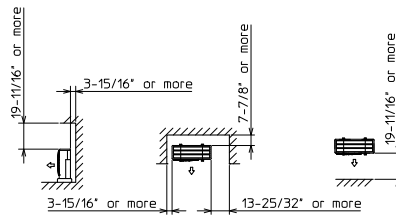

2. SERVICE SPACE

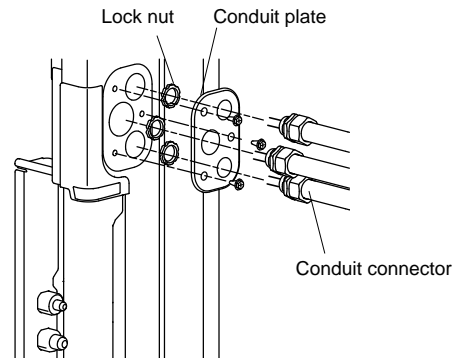
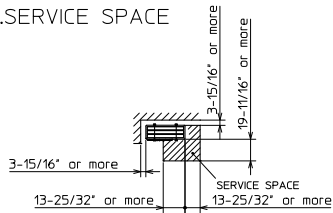

MXZ-3C24NAHZ
MXZ-3C30NAHZ

Unit: inch (mm)

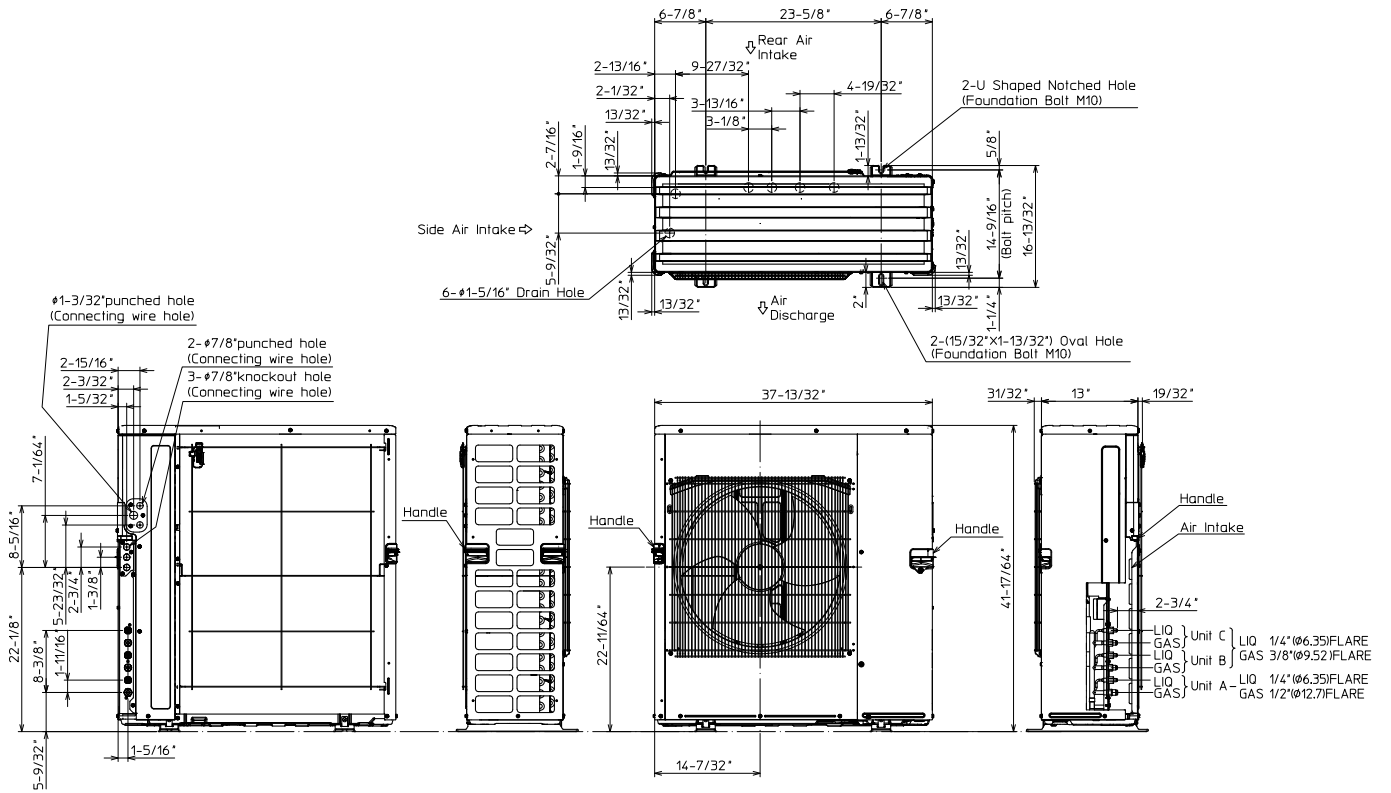

1.FREE SPACE

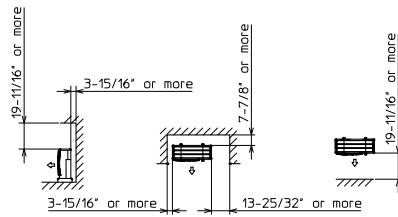



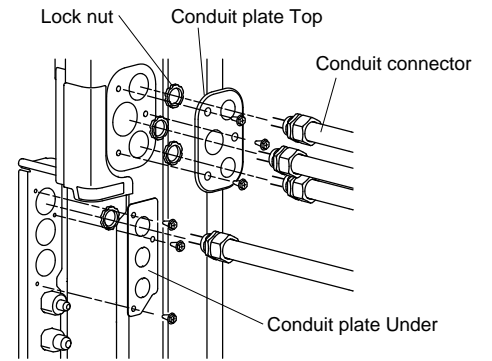
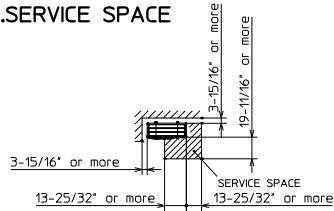

2.SERVICE SPACE

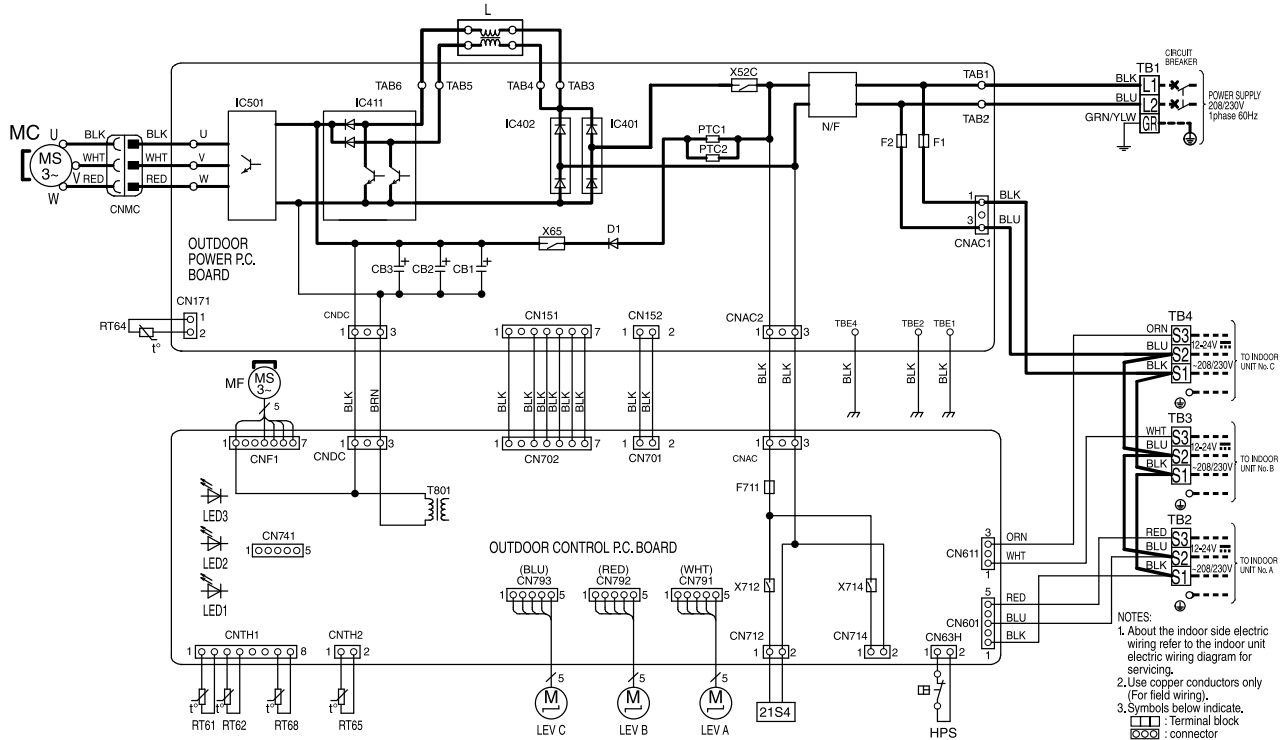

MXZ-3C24NA MXZ-3C30NA



SYMBOL	NAME	SYMBOL	NAME	SYMBOL	NAME	SYMBOL	NAME	SYMBOL	NAME
CB1-3	SMOOTHING CAPACITOR	IC501	POWER MODULE	PTC 1, 2	CIRCUIT PROTECTION	RT68	OUTDOOR HEAT EXCHANGER TEMPERATURE THERMISTOR	T801	TRANSFORMER
F1	FUSE (T6.3AL 250V)	L	REACTOR	RT61	DEFROST THERMISTOR	X52C	RELAY	TB1-4	TERMINAL BLOCK
F2	FUSE (T6.3AL 250V)	LED 1-3	LED	RT62	DISCHARGE TEMP. THERMISTOR	X65	RELAY	21S4	REVERSING VALVE SOLENOID COIL
F711	FUSE (T3.15AL 250V)	LEV A-C	EXPANSION VALVE	RT64	FIN TEMP. THERMISTOR	X712	RELAY		
HPS	HIGH PRESSURE SWITCH	MC	COMPRESSOR	RT65	AMBIENT TEMP. THERMISTOR	X714	RELAY		
IC411	POWER FACTOR CONTROLLER	MF	FAN MOTOR						

- NOTES:
- About the indoor side electric wiring refer to the indoor unit electric wiring diagram for servicing.
 - Use copper conductors only (For field wiring).
 - Symbols below indicate:
 : Terminal block
 : connector
- NOTES:
- A propos du câblage électrique de côté intérieur se référer à l'unité intérieure câblage schéma électrique pour l'entretien.
 - Utiliser des conducteurs en cuivre (pour le câblage).
 - Symbole ci-dessous indique:
 : bornier
 : connecteur

MXZ-4C36NA

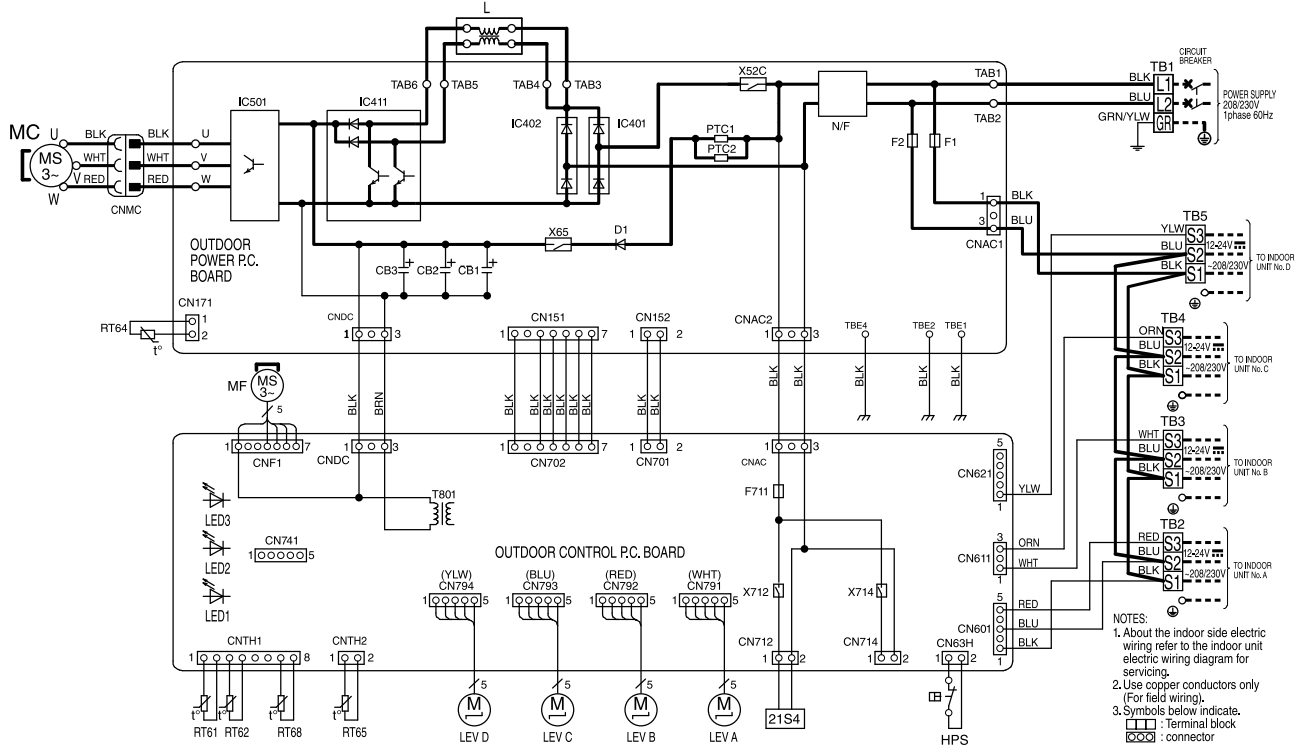

SYMBOL	NAME	SYMBOL	NAME	SYMBOL	NAME	SYMBOL	NAME	SYMBOL	NAME
CB1-3	SMOOTHING CAPACITOR	IC501	POWER MODULE	PTC 1, 2	CIRCUIT PROTECTION	RT68	OUTDOOR HEAT EXCHANGER TEMPERATURE THERMISTOR	T801	TRANSFORMER
F1	FUSE (T6.3AL 250V)	L	REACTOR	RT61	DEFROST THERMISTOR	X52C	RELAY	TB1-5	TERMINAL BLOCK
F2	FUSE (T6.3AL 250V)	LED 1-3	LED	RT62	DISCHARGE TEMP. THERMISTOR	X65	RELAY	21S4	REVERSING VALVE SOLENOID COIL
F711	FUSE (T3.15AL 250V)	LEV A-D	EXPANSION VALVE			X712	RELAY		
HPS	HIGH PRESSURE SWITCH	MC	COMPRESSOR	RT64	FIN TEMP. THERMISTOR	X714	RELAY		
IC411	POWER FACTOR CONTROLLER	MF	FAN MOTOR	RT65	AMBIENT TEMP. THERMISTOR				

NOTES:
 1. About the indoor side electric wiring refer to the indoor unit electric wiring diagram for servicing.
 2. Use copper conductors only (For field wiring).
 3. Symbols below indicate.
 [] Terminal block
 [] connector

MXZ-5C42NA

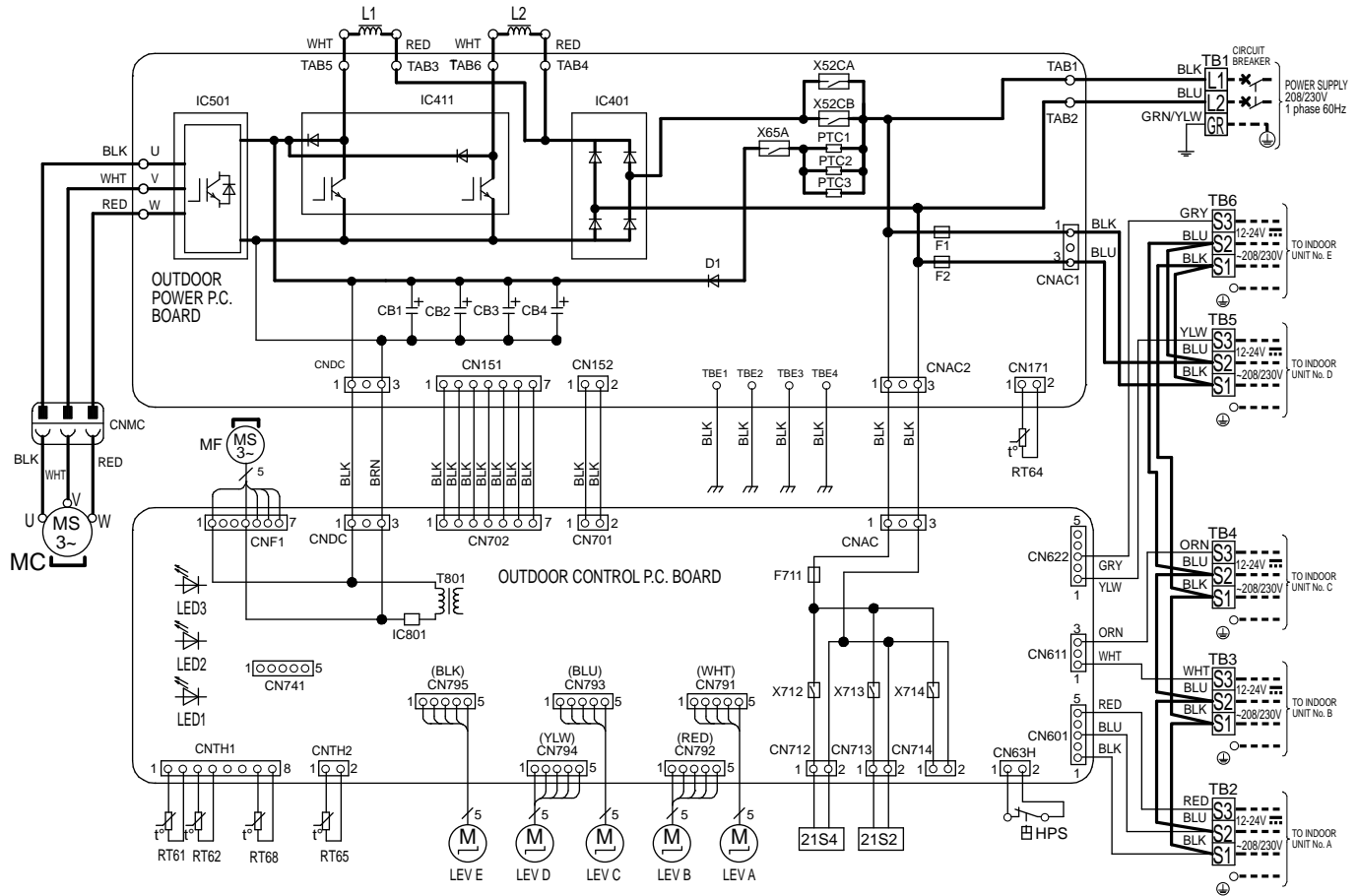

SYMBOL	NAME	SYMBOL	NAME
CB1-4	SMOOTHING CAPACITOR	L1, L2	REACTOR
D1	DIODE	LED 1-3	LED
F1, F2	FUSE (T6.3AL 250V)	LEV A-E	EXPANSION VALVE
F711	FUSE (T3.15AL 250V)	MC	COMPRESSOR
HPS	HIGH PRESSURE SWITCH	MF	FAN MOTOR
IC401	DIODE BRIDGE	T801	TRANSFORMER
IC411	POWER MODULE	TB1-6	TERMINAL BLOCK
IC501	POWER MODULE	X52CA, B	RELAY
IC801	POWER DEVICE	X65A	RELAY
PTC1-3	CIRCUIT PROTECTION	X712	RELAY
RT61	DEFROST THERMISTOR	X713	RELAY
RT62	DISCHARGE TEMP. THERMISTOR	X714	RELAY
RT64	FIN TEMP. THERMISTOR	21S2	2WAY VALVE SOLENOID COIL
RT65	AMBIENT TEMP. THERMISTOR	21S4	REVERSING VALVE SOLENOID COIL
RT68	OUTDOOR HEAT EXCHANGER TEMPERATURE THERMISTOR		

NOTES:

- About the indoor side electric wiring refer to the indoor unit electric wiring diagram for servicing.
- Use copper conductors only (For field wiring).
- Symbols below indicate.

□ □ □ : Terminal block
 ○ ○ ○ : connector

NOTES:

- À propos du câblage électrique de côté intérieur se référer à l'unité intérieure câblage schéma électrique pour l'entretien.
 - Utiliser des conducteurs en cuivre (pour le câblage).
 - Symbole ci-dessous indique.
- □ □ : bornier
 ○ ○ ○ : connecteur

MXZ-2C20NAHZ

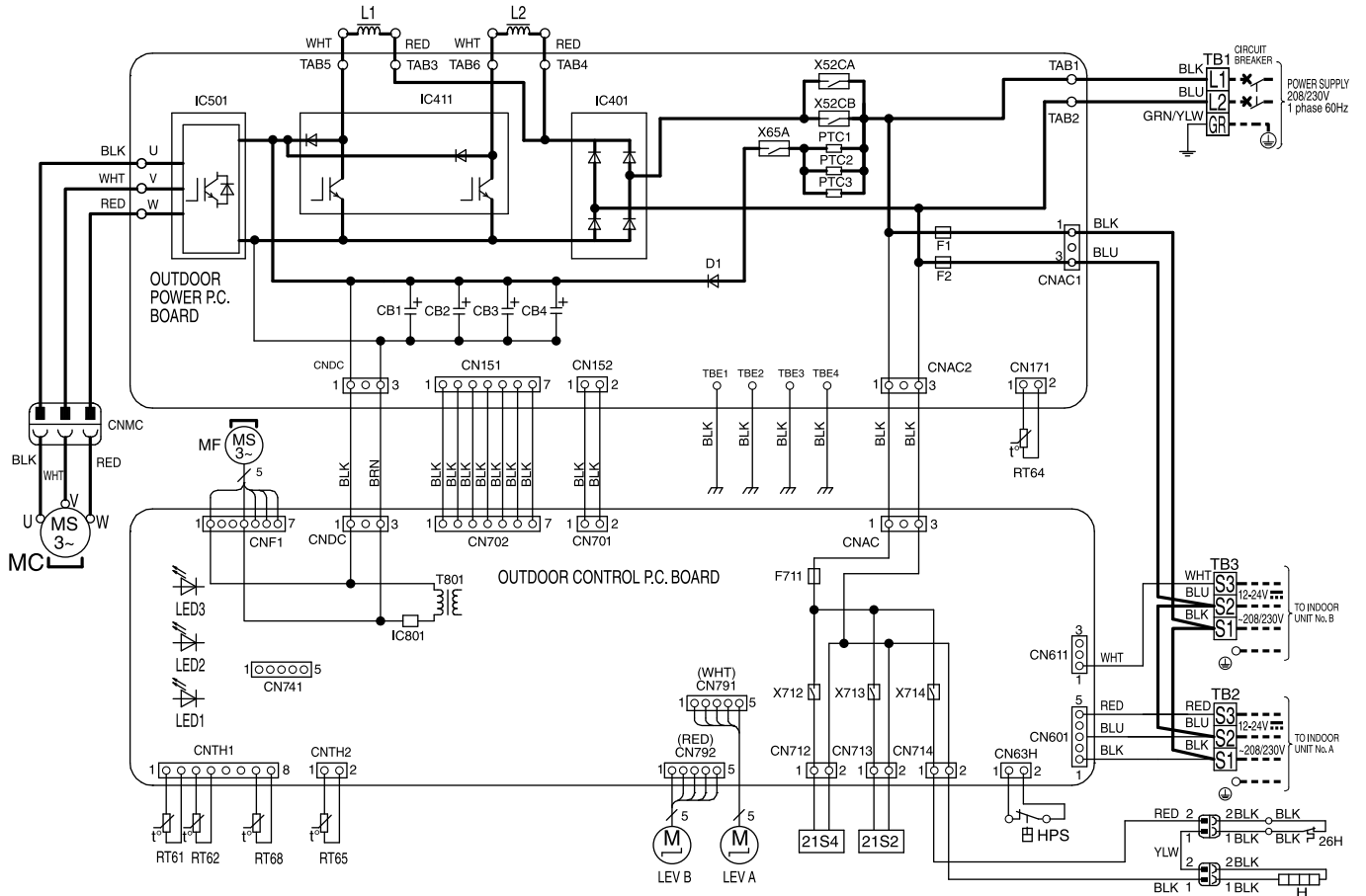

SYMBOL	NAME	SYMBOL	NAME
CB1-4	SMOOTHING CAPACITOR	L1, L2	REACTOR
D1	DIODE	LED 1-3	LED
F1, F2	FUSE (T6.3AL 250V)	LEV A, B	EXPANSION VALVE
F711	FUSE (T3.15AL 250V)	MC	COMPRESSOR
HPS	HIGH PRESSURE SWITCH	MF	FAN MOTOR
IC401	DIODE BRIDGE	T801	TRANSFORMER
IC411	POWER MODULE	TB1-3	TERMINAL BLOCK
IC501	POWER MODULE	X52CA, B	RELAY
IC801	POWER DEVICE	X65A	RELAY
PTC1-3	CIRCUIT PROTECTION	X712	RELAY
RT61	DEFROST THERMISTOR	X713	RELAY
RT62	DISCHARGE TEMP.THERMISTOR	X714	RELAY
RT64	FIN TEMP.THERMISTOR	21S2	2WAY VALVE SOLENOID COIL
RT65	AMBIENT TEMP.THERMISTOR	21S4	REVERSING VALVE SOLENOID COIL
RT68	OUTDOOR HEAT EXCHANGER TEMPERATURE THERMISTOR	26H	HEATER PROTECTOR
		H	DEFROST HEATER

NOTES:
 1.About the indoor side electric wiring refer to the indoor unit electric wiring diagram for servicing.
 2.Use copper conductors only (For field wiring).
 3.Symbols below indicate.
 □□□: Terminal block
 ○○○○: connector

NOTES:
 1.À propos du câblage électrique de côté intérieur se référer à l'unité intérieure câblage schéma électrique pour l'entretien.
 2.Utiliser des conducteurs en cuivre (pour le câblage).
 3.Symbole ci-dessous indique.
 □□□:bornier
 ○○○○:connecteur

MXZ-3C24NAHZ MXZ-3C30NAHZ

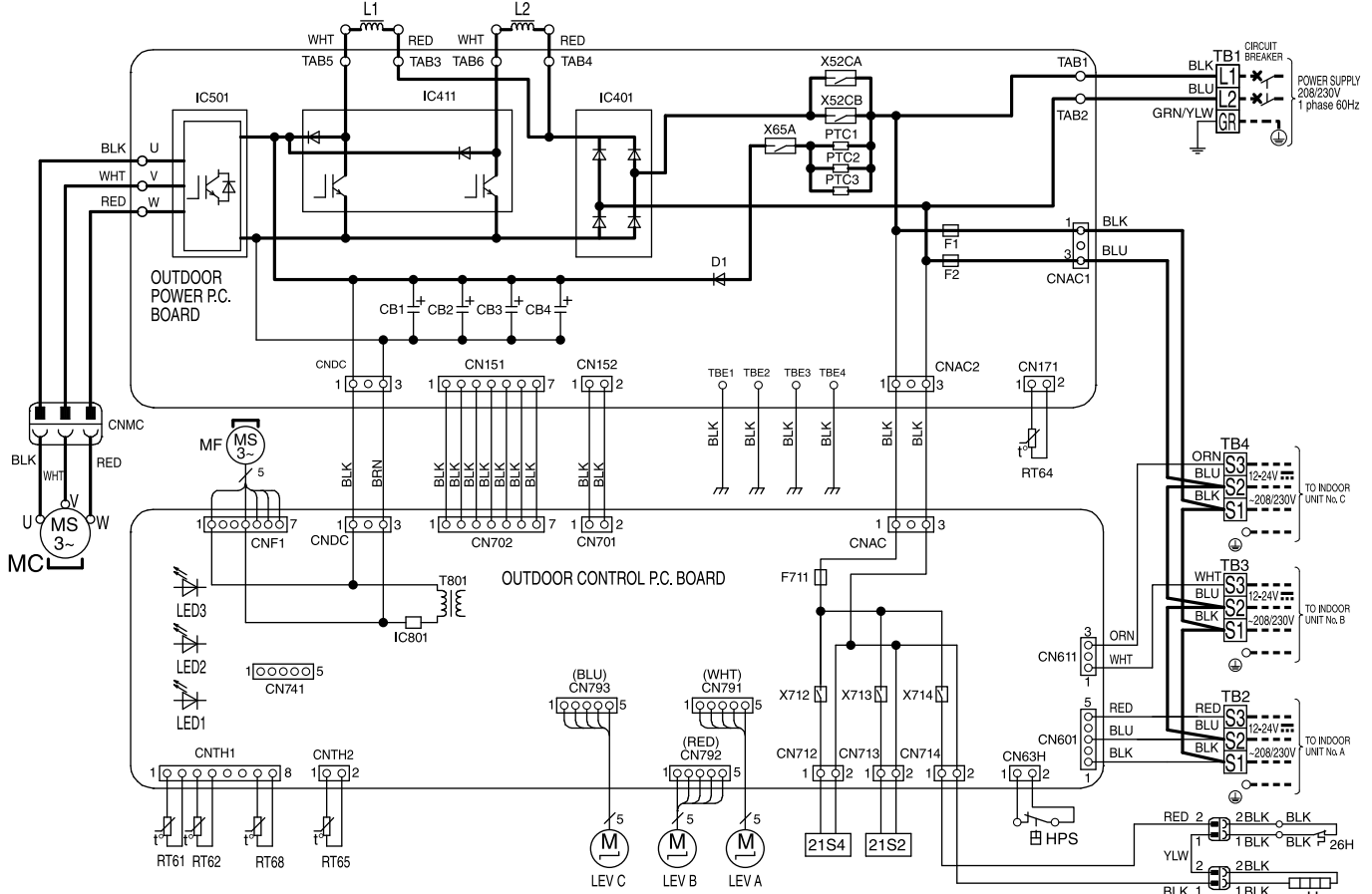

SYMBOL	NAME	SYMBOL	NAME
CB1-4	SMOOTHING CAPACITOR	L1, L2	REACTOR
D1	DIODE	LED 1-3	LED
F1, F2	FUSE (T6.3AL 250V)	LEV A-C	EXPANSION VALVE
F711	FUSE (T3.15AL 250V)	MC	COMPRESSOR
HPS	HIGH PRESSURE SWITCH	MF	FAN MOTOR
IC401	DIODE BRIDGE	T801	TRANSFORMER
IC411	POWER MODULE	TB1-4	TERMINAL BLOCK
IC501	POWER MODULE	X52CA, B	RELAY
IC801	POWER DEVICE	X65A	RELAY
PTC1-3	CIRCUIT PROTECTION	X712	RELAY
RT61	DEFROST THERMISTOR	X713	RELAY
RT62	DISCHARGE TEMP. THERMISTOR	X714	RELAY
RT64	FIN TEMP. THERMISTOR	21S2	2WAY VALVE SOLENOID COIL
RT65	AMBIENT TEMP. THERMISTOR	21S4	REVERSING VALVE SOLENOID COIL
RT68	OUTDOOR HEAT EXCHANGER TEMPERATURE THERMISTOR	26H	HEATER PROTECTOR
		H	DEFROST HEATER

NOTES:
 1. About the indoor side electric wiring refer to the indoor unit electric wiring diagram for servicing.
 2. Use copper conductors only (For field wiring).
 3. Symbols below indicate.
 □ □ □ : Terminal block
 ○ ○ ○ : connector

NOTES:
 1. À propos du câblage électrique de côté intérieur se référer à l'unité intérieure câblage schéma électrique pour l'entretien.
 2. Utiliser des conducteurs en cuivre (pour le câblage).
 3. Symbole ci-dessous indique.
 □ □ □ : bornier
 ○ ○ ○ : connecteur

MXZ-3C24NA
MXZ-3C30NA

Unit: inch (mm)

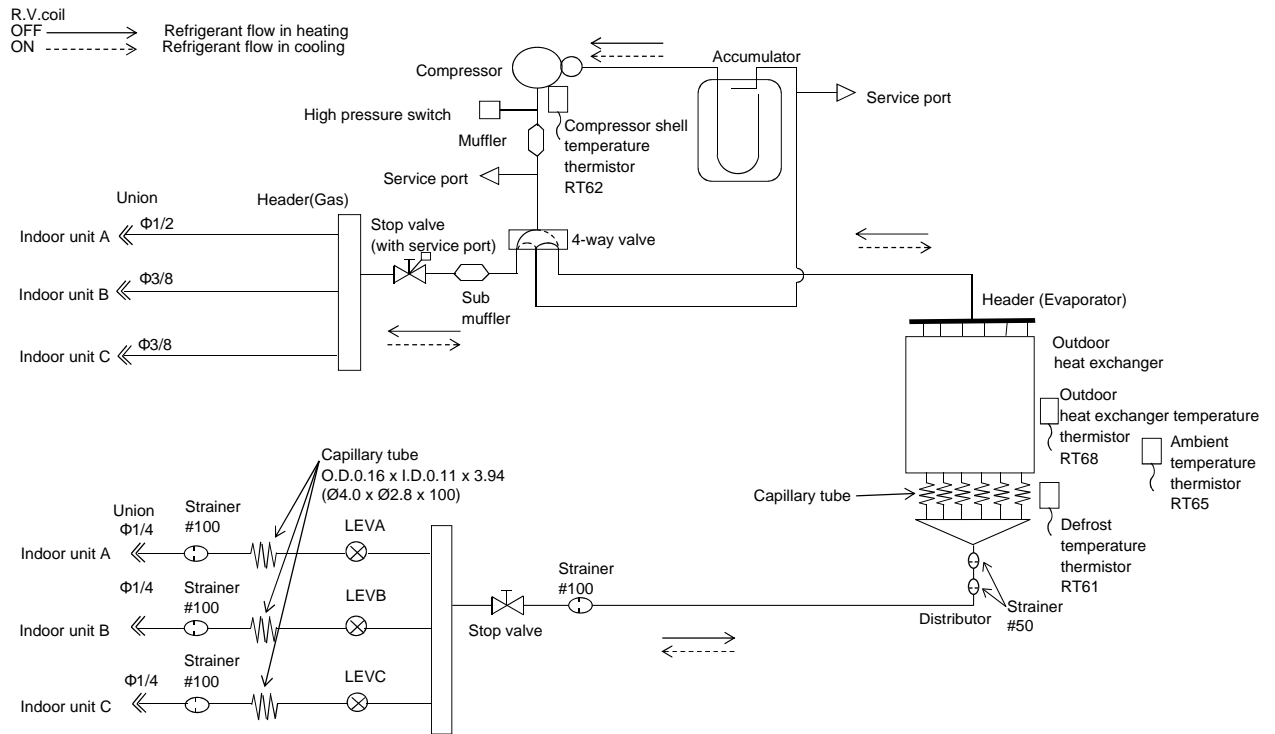

Operating Range MXZ-3C24NA MXZ-3C30NA

		Indoor intake air temperature	Outdoor intake air temperature
Cooling	Maximum	95°FDB, 71°FWB	115°FDB
	Minimum	67°FDB, 57°FWB	14°FDB
Heating	Maximum	80°FDB, 67°FWB	75°FDB, 65°FWB
	Minimum	70°FDB, 60°FWB	6°FDB, 5°FWB

MAX. REFRIGERANT PIPING LENGTH & PIPE SIZE SELECTION MXZ-3C24NA MXZ-3C30NA

Piping length each indoor unit (a, b, c)	82 ft. MAX.
Total piping length (a+b+c)	230 ft. MAX.
Bending point for each unit	25 MAX.
Total bending point	70 MAX.

*It is irrelevant which unit is higher.

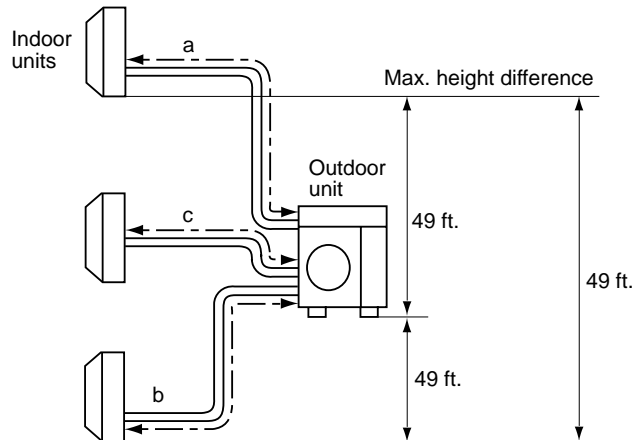

- Refrigerant pipe diameter is different according to indoor unit to be connected. When using extension pipes, refer to the tables below.
- When the diameter of refrigerant pipe is different from that of outdoor unit union, use optional Different-diameter pipe. For further information on Different-diameter pipe, refer to "PARTS CATALOG".

Unit : inch

Outdoor unit union diameter		
For		
Indoor unit A	Liquid	1/4
	Gas	1/2
Indoor unit B	Liquid	1/4
	Gas	3/8
Indoor unit C	Liquid	1/4
	Gas	3/8

MXZ-4C36NA

Unit: inch (mm)

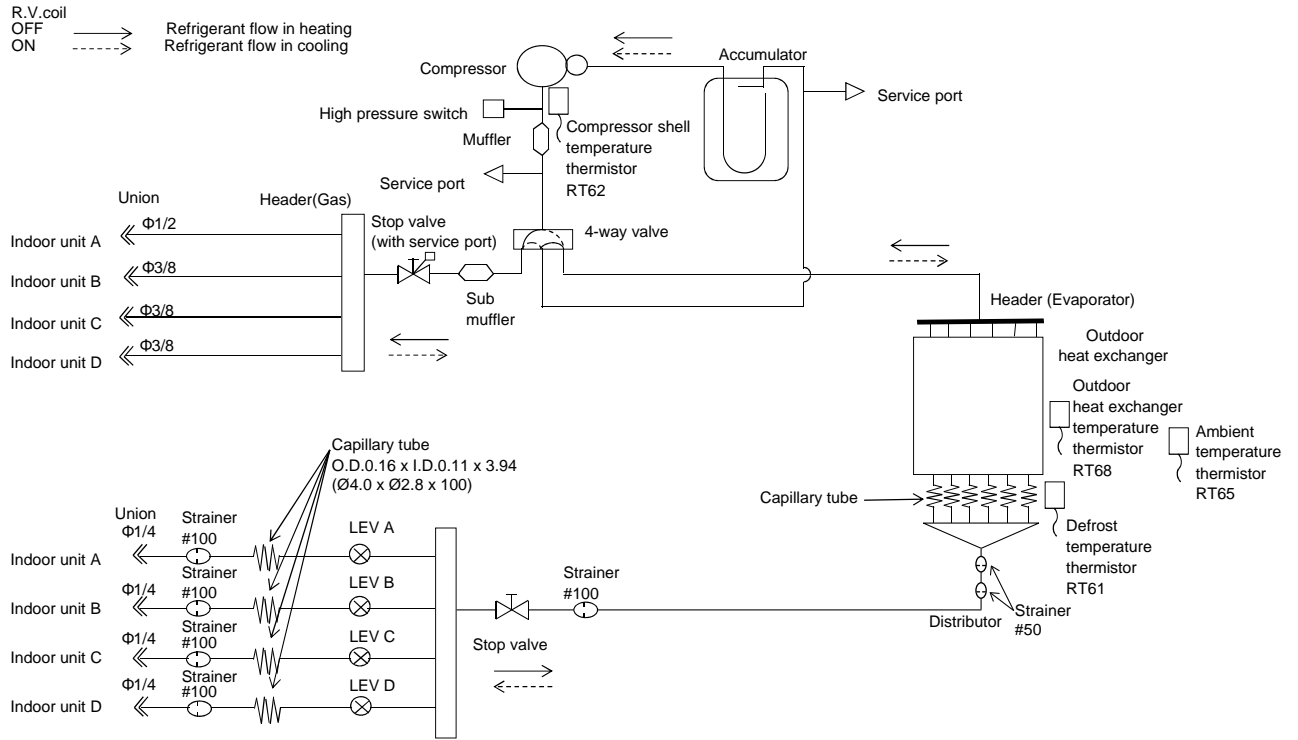

Operating Range MXZ-4C36NA

		Indoor intake air temperature	Outdoor intake air temperature
Cooling	Maximum	95°FDB, 71°FWB	115°FDB
	Minimum	67°FDB, 57°FWB	14°FDB
Heating	Maximum	80°FDB, 67°FWB	75°FDB, 65°FWB
	Minimum	70°FDB, 60°FWB	6°FDB, 5°FWB

MAX. REFRIGERANT PIPING LENGTH & PIPE SIZE SELECTION MXZ-4C36NA

Piping length each indoor unit (a, b, c, d)	82 ft. MAX.
Total piping length (a+b+c+d)	230 ft. MAX.
Bending point for each unit	25 MAX.
Total bending point	70 MAX.

*It is irrelevant which unit is higher.

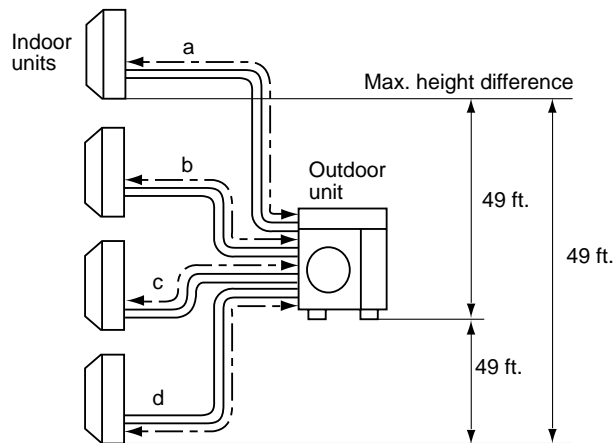

- Refrigerant pipe diameter is different according to indoor unit to be connected. When using extension pipes, refer to the tables below.
- When the diameter of refrigerant pipe is different from that of outdoor unit union, use optional Different-diameter pipe. For further information on Different-diameter pipe, refer to "PARTS CATALOG".

Unit : inch

Outdoor unit union diameter		
For		
Indoor unit A	Liquid	1/4
	Gas	1/2
Indoor unit B	Liquid	1/4
	Gas	3/8
Indoor unit C	Liquid	1/4
	Gas	3/8
Indoor unit D	Liquid	1/4
	Gas	3/8

MXZ-5C42NA

Unit: inch (mm)

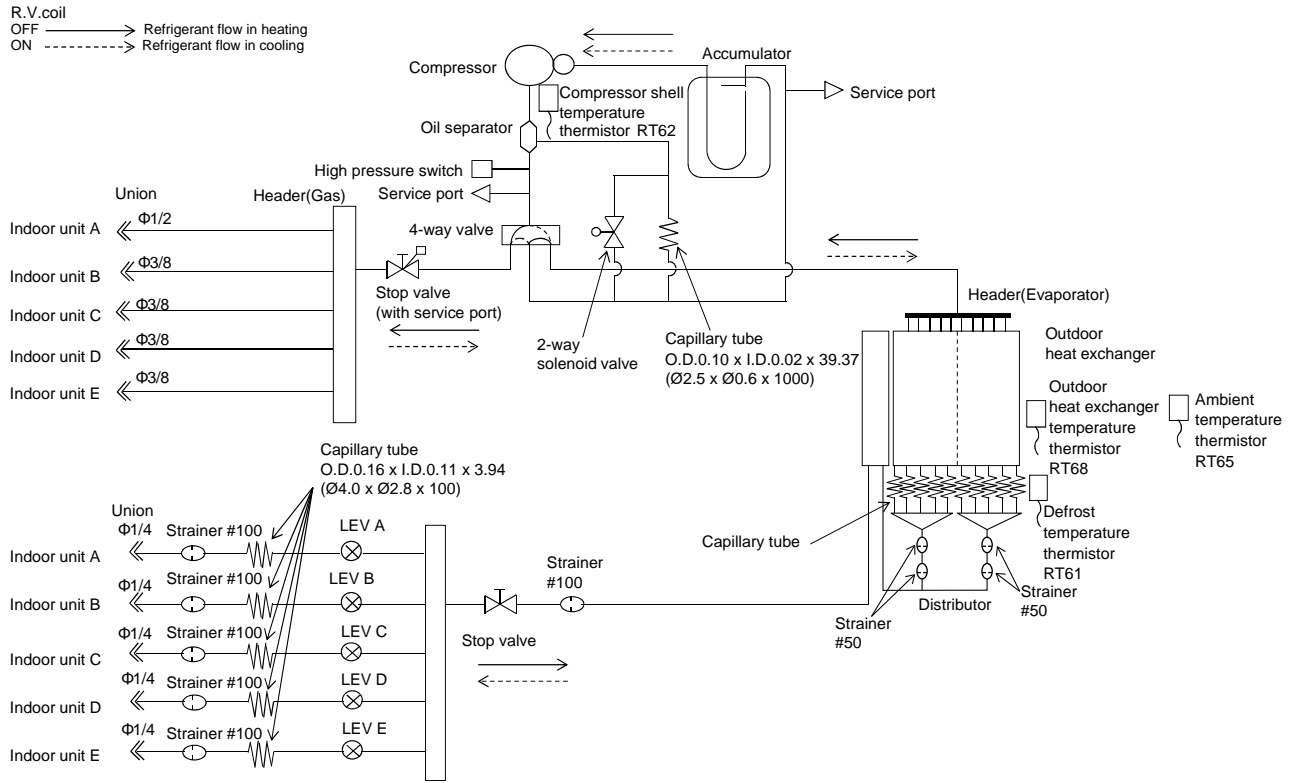

Operating Range MXZ-5C42NA

		Indoor intake air temperature	Outdoor intake air temperature
Cooling	Maximum	95°FDB, 71°FWB	115°FDB
	Minimum	67°FDB, 57°FWB	14°FDB
Heating	Maximum	80°FDB, 67°FWB	75°FDB, 65°FWB
	Minimum	70°FDB, 60°FWB	6°FDB, 5°FWB

MAX. REFRIGERANT PIPING LENGTH & PIPE SIZE SELECTION MXZ-5C42NA

Piping length each indoor unit (a, b, c, d, e)	82 ft. MAX.
Total piping length (a+b+c+d+e)	262 ft. MAX.
Bending point for each unit	25 MAX.
Total bending point	80 MAX.

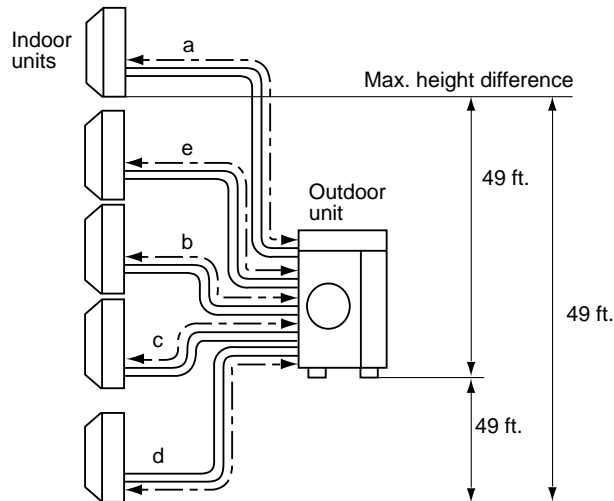

- Refrigerant pipe diameter is different according to indoor unit to be connected. When using extension pipes, refer to the tables below.
- When diameter of refrigerant pipe is different from that of outdoor unit union, use optional Different-diameter pipe. For further information on Different-diameter pipe, refer to "PARTS CATALOG".

Unit : inch		
Outdoor unit union diameter		
For		
Indoor unit A	Liquid	1/4
	Gas	1/2
Indoor unit B	Liquid	1/4
	Gas	3/8
Indoor unit C	Liquid	1/4
	Gas	3/8
Indoor unit D	Liquid	1/4
	Gas	3/8
Indoor unit E	Liquid	1/4
	Gas	3/8

MXZ-2C20NAHZ

Unit: inch (mm)

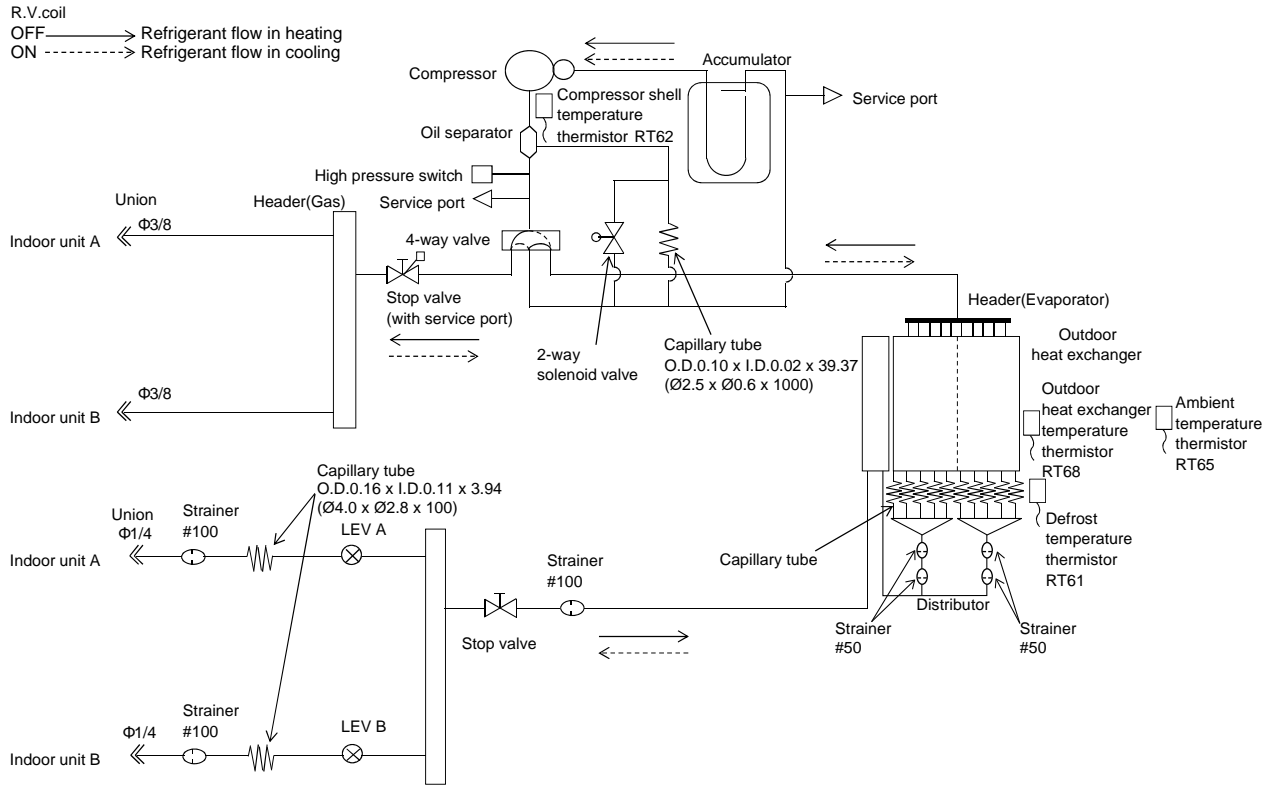

Operating Range MXZ-2C20AHZ

		Indoor intake air temperature	Outdoor intake air temperature
Cooling	Maximum	95°FDB, 71°FWB	115°FDB
	Minimum	67°FDB, 57°FWB	14°FDB
Heating	Maximum	80°FDB, 67°FWB	75°FDB, 65°FWB
	Minimum	70°FDB, 60°FWB	-12°FDB, -13°FWB

MAX. REFRIGERANT PIPING LENGTH & PIPE SIZE SELECTION MXZ-2C20AHZ

Piping length each indoor unit (a, b)	82 ft. MAX.
Total piping length (a+b)	164 ft. MAX.
Bending point for each unit	25 MAX.
Total bending point	50 MAX.

*It is irrelevant which unit is higher.

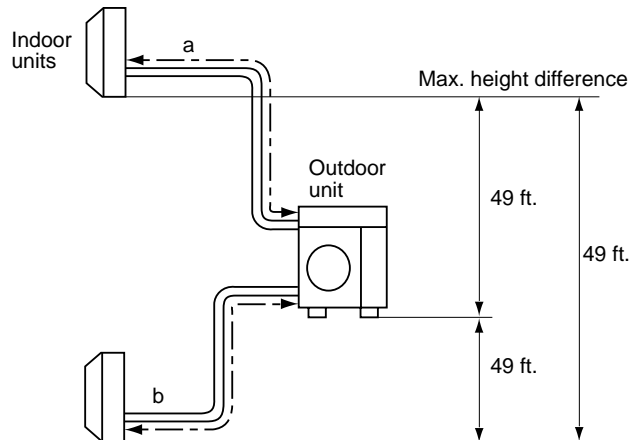

- Refrigerant pipe diameter is different according to indoor unit to be connected. When using extension pipes, refer to the tables below.
- When the diameter of refrigerant pipe is different from that of outdoor unit union, use optional Different-diameter pipe. For further information on Different-diameter pipe, refer to "PARTS CATALOG".

Unit: inch

Outdoor unit union diameter		
For		
Indoor unit A	Liquid	1/4
	Gas	3/8
Indoor unit B	Liquid	1/4
	Gas	3/8

MXZ-3C24NAHZ
MXZ-3C30NAHZ

Unit: inch (mm)

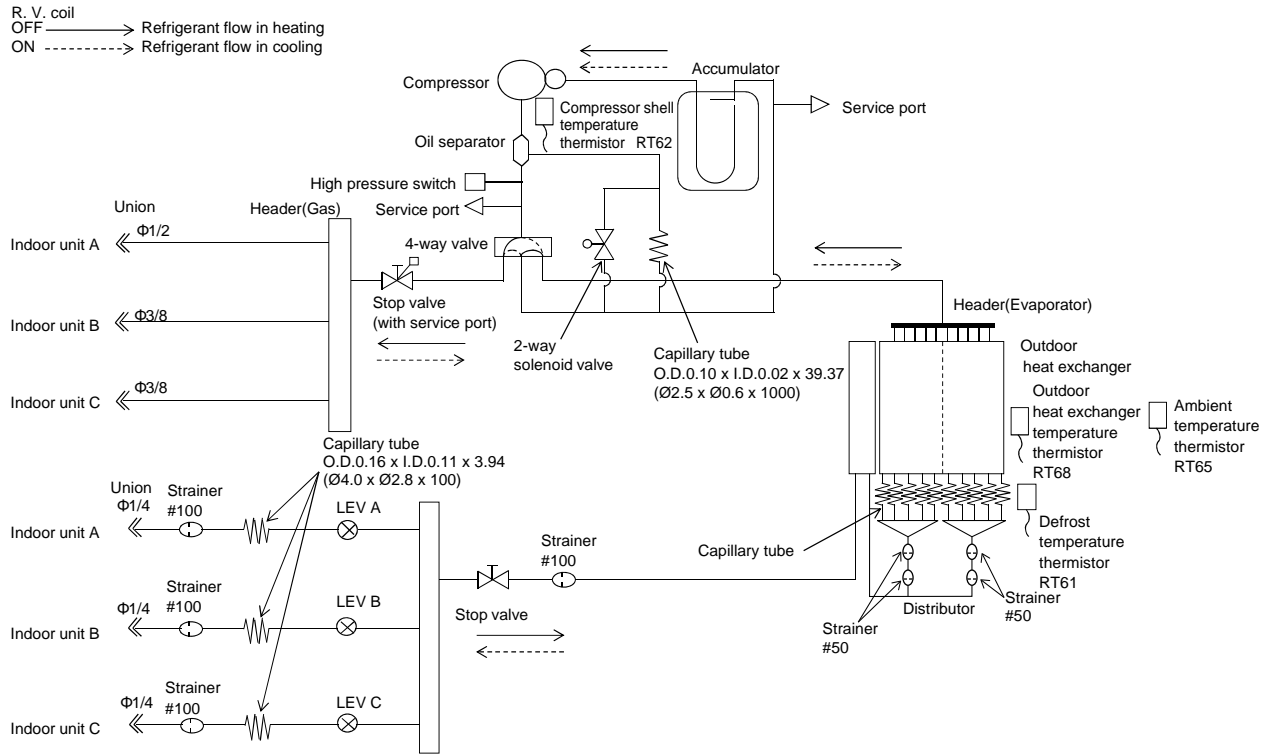

Operating Range MXZ-3C24NAHZ MXZ-3C30NAHZ

		Indoor intake air temperature	Outdoor intake air temperature
Cooling	Maximum	95°FDB, 71°FWB	115°FDB
	Minimum	67°FDB, 57°FWB	14°FDB
Heating	Maximum	80°FDB, 67°FWB	75°FDB, 65°FWB
	Minimum	70°FDB, 60°FWB	-12°FDB, -13°FWB

MAX. REFRIGERANT PIPING LENGTH & PIPE SIZE SELECTION MXZ-3C24NAHZ MXZ-3C30NAHZ

Piping length each indoor unit (a, b, c)	82 ft. MAX.
Total piping length (a+b+c)	230 ft. MAX.
Bending point for each unit	25 MAX.
Total bending point	70 MAX.

*It is irrelevant which unit is higher.

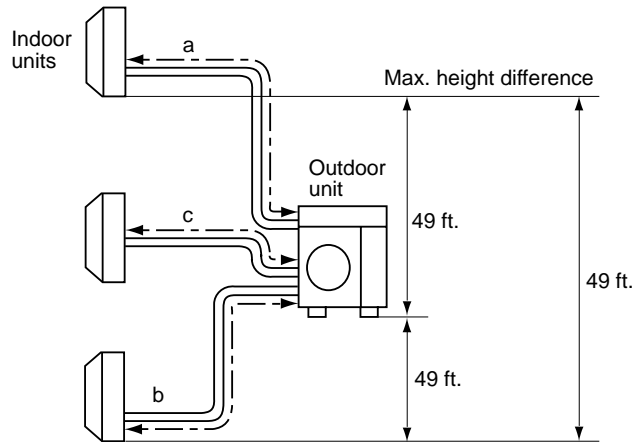

- Refrigerant pipe diameter is different according to indoor unit to be connected. When using extension pipes, refer to the tables below.
- When the diameter of refrigerant pipe is different from that of outdoor unit union, use optional Different-diameter pipe. For further information on Different-diameter pipe, refer to "PARTS CATALOG".

Unit : inch

Outdoor unit union diameter		
For		
Indoor unit A	Liquid	1/4
	Gas	1/2
Indoor unit B	Liquid	1/4
	Gas	3/8
Indoor unit C	Liquid	1/4
	Gas	3/8

PUMPING DOWN

When relocating or disposing of the air conditioner, pump down the system following the procedure below so that no refrigerant is released into the atmosphere.

- 1) Turn off the breaker.
- 2) Connect the gauge manifold valve to the service port of the stop valve on the gas pipe side of the outdoor unit.
- 3) Fully close the stop valve on the liquid pipe side of the outdoor unit.
- 4) Turn on the breaker.
- 5) Start the emergency COOL operation on all the indoor units.
- 6) When the pressure gauge shows 0.1 to 0 psi [Gauge] (0.05 to 0 MPa), fully close the stop valve on the gas pipe side of the outdoor unit and stop the operation. (Refer to the indoor unit installation manual about the method for stopping the operation.)
 - * If too much refrigerant has been added to the air conditioner system, the pressure may not drop to 0.1 to 0 psi [Gauge] (0.05 to 0 MPa), or the protection function may operate due to the pressure increase in the high-pressure refrigerant circuit. If this occurs, use a refrigerant collecting device to collect all of the refrigerant in the system, and then recharge the system with the correct amount of refrigerant after the indoor and outdoor units have been relocated.
- 7) Turn off the breaker. Remove the pressure gauge and the refrigerant piping.

WARNING

When pumping down the refrigerant, stop the compressor before disconnecting the refrigerant pipes. The compressor may burst and cause injury if any foreign substance, such as air, enters the pipes.

Model			MXZ-3C24NA				
Indoor type			Non-Duct (06+06+09)		Duct (09+09+09)		
Item	Unit		Cooling	Heating	Cooling	Heating	
Total	Capacity	Btu/h	22,000	25,000	23,600	24,600	
	SHF	–	–	–	–	–	
	Input	kW	1.62	1.75	2.10	1.90	
Electrical circuit	Power supply (V, phase, Hz)		208/230, 1, 60				
	Input	kW	1.554	1.684	1.920	1.780	
	Comp. current (208/230V)	A	7.47 / 6.76	8.1 / 7.32	9.23 / 8.35	8.56 / 7.74	
	Fan motor current	A	0.3	0.3	0.3	0.3	
Refrigerant circuit	Condensing pressure	PSIG	395	310	419	345	
	Suction pressure	PSIG	162	101	138	102	
	Discharge temperature	°F	143	137	155	141	
	Condensing temperature	°F	116	98	120	106	
	Suction temperature	°F	59	36	50	34	
	Comp. shell bottom temp.	°F	137	128	146	131	
	Ref. pipe length [Total pipe length for multi-system]	ft	25[75]				
	Refrigerant charge (R410A)	–	6lb. 13oz.				
Outdoor unit	Intake air temperature	DB	°F	95	47	95	47
		WB	°F	-	43	-	43
	Fan speed	rpm	720	750	720	750	
	Airflow	CFM	2,287	2,382	2,287	2,382	

Model			MXZ-3C30NA				
Indoor type			Non-Duct (09+09+12)		Duct (09+09+12)		
Item	Unit		Cooling	Heating	Cooling	Heating	
Total	Capacity	Btu/h	28,400	28,600	27,400	27,600	
	SHF	–	–	–	–	–	
	Input	kW	2.68	2.15	2.84	2.22	
Electrical circuit	Power supply (V, phase, Hz)		208/230, 1, 60				
	Input	kW	2.614	2.084	2.650	2.090	
	Comp. current (208/230V)	A	12.57 / 11.37	10.02 / 9.06	12.74 / 11.52	10.05 / 9.09	
	Fan motor current	A	0.3	0.3	0.3	0.3	
Refrigerant circuit	Condensing pressure	PSIG	432	323	439	323	
	Suction pressure	PSIG	137	97	132	99	
	Discharge temperature	°F	159	136	165	136	
	Condensing temperature	°F	122	101	124	101	
	Suction temperature	°F	49	32	47	32	
	Comp. shell bottom temp.	°F	145	121	156	128	
	Ref. pipe length [Total pipe length for multi-system]	ft	25[75]				
	Refrigerant charge (R410A)	–	6 lb.13 oz.				
Outdoor unit	Intake air temperature	DB	°F	95	47	95	47
		WB	°F	-	43	-	43
	Fan speed	rpm	720	750	720	750	
	Airflow	CFM	2,287	2,382	2,287	2,382	



Model				MXZ-4C36NA			
Indoor type				Non-Duct (09+09+09+09)		Duct (09+09+09+09)	
Item		Unit		Cooling	Heating	Cooling	Heating
Total	Capacity	Btu/h		35,400	36,000	34,400	34,400
	SHF	-		-	-	-	-
	Input	kW		3.76	3.02	3.94	3.10
Electrical circuit	Power supply (V, phase, Hz)		208/230, 1, 60				
	Input	kW		3.672	2.932	3.700	2.940
	Comp. current (208/230V)		A	17.65 / 15.97	14.1 / 12.75	17.79 / 16.09	14.13 / 12.78
	Fan motor current		A	0.3	0.3	0.3	0.3
Refrigerant circuit	Condensing pressure		PSIG	461	297	470	334
	Suction pressure		PSIG	141	89	129	91
	Discharge temperature		°F	172	138	176	147
	Condensing temperature		°F	127	95	129	103
	Suction temperature		°F	51	28	46	29
	Comp. shell bottom temp.		°F	162	130	165	139
	Ref. pipe length [Total pipe length for multi-system]		ft	25[100]			
	Refrigerant charge (R410A)		-	6 lb.13 oz.			
Outdoor unit	Intake air temperature	DB	°F	95	47	95	47
		WB	°F	-	43	-	43
	Fan speed		rpm	720	750	720	750
	Airflow		CFM	2,287	2,382	2,287	2,382



Model			MXZ-5C42NA				
Indoor type			Non-Duct (06+09+09+09+09)		Duct (09+09+09+09+09)		
Item		Unit	Cooling	Heating	Cooling	Heating	
Total	Capacity	Btu/h	40,500	45,000	37,500	41,000	
	SHF	-	-	-	-	-	
	Input	kW	4.41	3.58	4.17	3.47	
Electrical circuit	Power supply (V, phase, Hz)		208/230, 1, 60				
	Input	kW	4.300	3.465	3.870	3.270	
	Comp. current (208/230V)	A	20.67/18.7	16.66/15.07	18.61/16.83	15.72/14.22	
	Fan motor current	A	0.43/0.39	0.43/0.39	0.43/0.39	0.43/0.39	
Refrigerant circuit	Condensing pressure		PSIG	466	305	446	326
	Suction pressure		PSIG	153	93	137	98
	Discharge temperature		°F	172	155	165	143
	Condensing temperature		°F	127	97	124	102
	Suction temperature		°F	53	27	47	29
	Comp. shell bottom temp.		°F	156	138	145	121
	Ref. pipe length [Total pipe length for multi-system]		ft	25 [80]			
	Refrigerant charge (R410A)		-	8 lb. 13 oz.			
Outdoor unit	Intake air temperature	DB	°F	95	47	95	47
		WB	°F	-	43	-	43
	Fan speed		rpm	630	730	630	730
	Airflow		CFM	2,118	2,542	2,118	2,542

Model			MXZ-2C20NAHZ				
Indoor type			Non-Duct (09+09)		Duct (09+12)		
Item		Unit	Cooling	Heating	Cooling	Heating	
Total	Capacity	Btu/h	18,000	22,000	20,000	22,000	
	SHF	-	-	-	-	-	
	Input	kW	1.34	1.62	1.82	1.75	
Electrical circuit	Power supply (V, phase, Hz)		208/230, 1, 60				
	Input	kW	1.296	1.574	1.670	1.660	
	Comp. current (208/230V)	A	6.23/5.63	7.57/6.84	8.03/7.26	7.98/7.22	
	Fan motor current	A	0.43/0.39	0.43/0.39	0.43/0.39	0.43/0.39	
Refrigerant circuit	Condensing pressure		PSIG	406	341	406	334
	Suction pressure		PSIG	154	110	133	113
	Discharge temperature		°F	158	131	148	141
	Condensing temperature		°F	108	105	112	103
	Suction temperature		°F	60	37	46	37
	Comp. shell bottom temp.		°F	137	107	127	117
	Ref. pipe length [Total pipe length for multi-system]		ft	25 [50]			
	Refrigerant charge (R410A)		-	8 lb. 13 oz.			
Outdoor unit	Intake air temperature	DB	°F	95	47	95	47
		WB	°F	-	43	-	43
	Fan speed		rpm	630	730	630	730
	Airflow		CFM	2,118	2,542	2,118	2,542



Model			MXZ-3C24NAHZ				
Indoor type			Non-Duct (06+06+09)		Duct (09+09+09)		
Item		Unit	Cooling	Heating	Cooling	Heating	
Total	Capacity	Btu/h	22,000	25,000	23,600	24,600	
	SHF	-	-	-	-	-	
	Input	kW	1.63	1.73	2.36	1.88	
Electrical circuit	Power supply (V, phase, Hz)		208/230, 1, 60				
	Input	kW	1.564	1.661	2.180	1.760	
	Comp. current (208/230V)	A	7.52/6.8	7.99/7.22	10.48/9.48	8.46/7.65	
	Fan motor current	A	0.43/0.39	0.43/0.39	0.43/0.39	0.43/0.39	
Refrigerant circuit	Condensing pressure	PSIG	397	302	377	329	
	Suction pressure	PSIG	164	106	136	109	
	Discharge temperature	°F	144	122	152	127	
	Condensing temperature	°F	114	97	115	103	
	Suction temperature	°F	59	42	48	36	
	Comp. shell bottom temp.	°F	128	105	136	109	
	Ref. pipe length [Total pipe length for multi-system]	ft	25 [70]				
Refrigerant charge (R410A)	-	8 lb. 13 oz.					
Outdoor unit	Intake air temperature	DB	°F	95	47	95	47
		WB	°F	-	43	-	43
	Fan speed	rpm	630	730	630	730	
	Airflow	CFM	2,118	2,542	2,118	2,542	

Model			MXZ-3C30NAHZ				
Indoor type			Non-Duct (09+09+12)		Duct (09+09+12)		
Item		Unit	Cooling	Heating	Cooling	Heating	
Total	Capacity	Btu/h	28,400	28,600	27,400	27,600	
	SHF	-	-	-	-	-	
	Input	kW	2.28	2.10	2.67	2.19	
Electrical circuit	Power supply (V, phase, Hz)		208/230, 1, 60				
	Input	kW	2.214	2.031	2.480	2.060	
	Comp. current (208/230V)	A	10.64/9.63	9.76/8.83	11.92/10.78	9.9/8.96	
	Fan motor current	A	0.43/0.39	0.43/0.39	0.43/0.39	0.43/0.39	
Refrigerant circuit	Condensing pressure	PSIG	404	321	416	329	
	Suction pressure	PSIG	146	103	131	107	
	Discharge temperature	°F	146	131	153	128	
	Condensing temperature	°F	117	101	118	103	
	Suction temperature	°F	52	35	45	35	
	Comp. shell bottom temp.	°F	129	111	135	108	
	Ref. pipe length [Total pipe length for multi-system]	ft	25 [70]				
Refrigerant charge (R410A)	-	8 lb. 13 oz.					
Outdoor unit	Intake air temperature	DB	°F	95	47	95	47
		WB	°F	-	43	-	43
	Fan speed	rpm	650	730	650	730	
	Airflow	CFM	2,224	2,542	2,224	2,542	

8-1. OPERATING RANGE

(1) POWER SUPPLY

	Model	Rating	Guaranteed Voltage
Outdoor unit	MXZ-3C24NA MXZ-2C20NAHZ MXZ-3C30NA MXZ-3C24NAHZ MXZ-4C36NA MXZ-3C30NAHZ MXZ-5C42NA	208/230 V 60 Hz 1 ϕ	Min. 198 V 208 V 230 V Max. 253 V ----- ----- ----- ----- -----

(2) OPERATION

Function	Intake air temperature Condition	Indoor		Outdoor	
		DB (°F)	WB (°F)	DB (°F)	WB (°F)
Cooling	"A" Cooling steady state at rated compressor speed	80	67	95	(75)
	"B-2" Cooling steady state at rated compressor speed	80	67	82	(65)
	"B-1" Cooling steady state at minimum compressor speed	80	67	82	(65)
	Low ambient cooling steady state at minimum compressor speed	80	67	67	(53.5)
	Intermediate cooling steady state at intermediate compressor speed	80	67	87	(69)
Heating	Standard rating-heating at rated compressor speed	70	60	47	43
	Low temperature heating at rated compressor speed	70	60	17	15
	Max. temperature heating at minimum compressor speed	70	60	62	56.5
	High temperature heating at minimum compressor speed	70	60	47	43
	Frost accumulation at rated compressor speed	70	60	35	33
	Frost accumulation at intermediate compressor speed	70	60	35	33

**MXZ-3C24NA MXZ-3C30NA MXZ-4C36NA MXZ-5C42NA
MXZ-2C20NAHZ MXZ-3C24NAHZ MXZ-3C30NAHZ**

The standard specifications apply only to the operation of the air conditioner under normal conditions. Since operating conditions vary according to the areas where these units are installed, the following information has been provided to clarify the operating characteristics of the air conditioner under the conditions indicated by the performance curve.

(1) GUARANTEED VOLTAGE

198 ~ 253 V 60 Hz

(2) AIR FLOW

Air flow should be set at MAX.

(3) MAIN READINGS

- | | | |
|---|------|-----------|
| (1) Indoor intake air wet-bulb temperature : | °FWB | } Cooling |
| (2) Indoor outlet air wet-bulb temperature : | °FWB | |
| (3) Outdoor intake air dry-bulb temperature : | °FDB | |
| (4) Total input : | W | |
| (5) Indoor intake air dry-bulb temperature : | °FDB | } Heating |
| (6) Outdoor intake air wet-bulb temperature : | °FWB | |
| (7) Total input : | W | |

Indoor air wet and dry bulb temperature difference on the left side of the following chart shows the difference between the indoor intake air wet and dry bulb temperature and the indoor outlet air wet and dry bulb temperature for your reference at service.

How to measure the indoor air wet and dry bulb temperature difference

1. Attach at least 2 sets of wet and dry bulb thermometers to the indoor air intake as shown in the figure, and at least 2 sets of wet and dry bulb thermometers to the indoor air outlet. The thermometers must be attached to the position where air speed is high.
2. Attach at least 2 sets of wet and dry bulb thermometers to the outdoor air intake. Cover the thermometers to prevent direct rays of the sun.
3. Check that the air filter is cleaned.
4. Open windows and doors of room.
5. Press the EMERGENCY OPERATION switch once (twice) to start the EMERGENCY COOL (HEAT) MODE.
6. Compressor starts running at 33 Hz (COOL) or 45 Hz (HEAT). The frequency at each operation mode is fixed.
7. When system stabilizes after more than 15 minutes, measure temperature and take an average temperature.
8. 10 minutes later, measure temperature again and check that the temperature does not change.

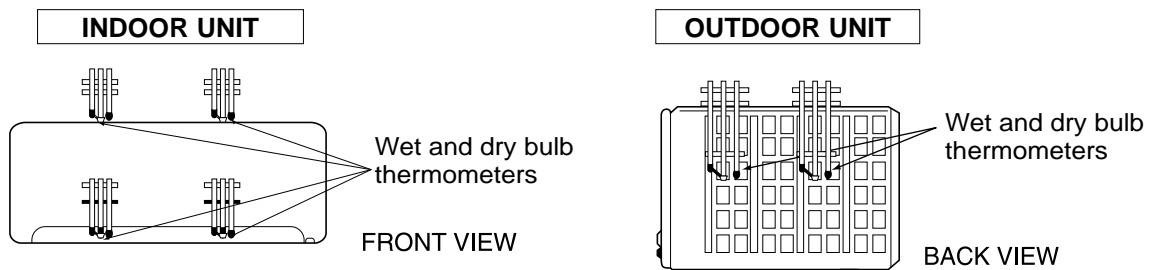

8-2. CAPACITY AND THE INPUT CURVES MXZ-3C24NA MXZ-3C30NA MXZ-4C36NA

Indoor unit class (Inverter output frequency)	Indoor air Wet-bulb temperature difference (degree)	Capacity correction factors
06 class (19Hz)	7.9	1.5
09 class (24Hz)	11.3	1.4
12 class (31Hz)	13.8	1.3
15 class (35Hz)	13.5	1.2
18 class (42Hz)	17.1	1.1
* 24 class (54Hz)	15.6	1.0
	7.3	0.9
	6.8	0.8
	6.2	0.7
	5.7	0.6
	5.1	0.5
	4.6	0.4

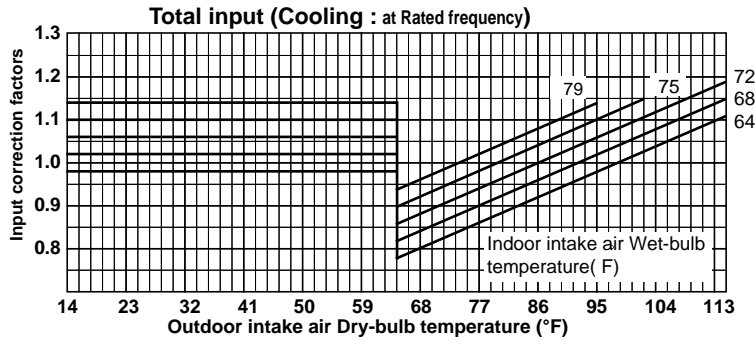
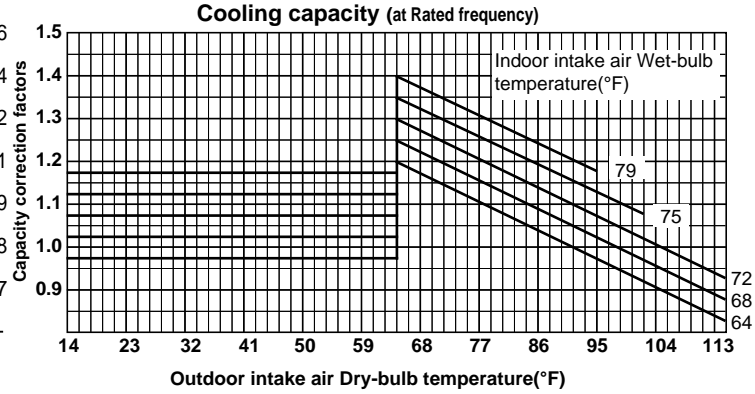

Indoor unit class (Inverter output frequency)	Indoor air Dry-bulb temperature difference (degree)	Capacity correction factors
06 class (23Hz)	24.3	1.3
09 class (29Hz)	34.0	1.2
12 class (36Hz)	44.8	1.1
15 class (43Hz)	49.1	1.0
18 class (50Hz)	53.3	0.9
* 24 class (62Hz)	39.8	0.8
	22.5	0.7
	20.5	0.6
	18.5	0.5
	16.6	0.4
	14.8	0.3
	13.0	0.2
	11.0	0.1
	9.2	0.0
	7.4	0.0

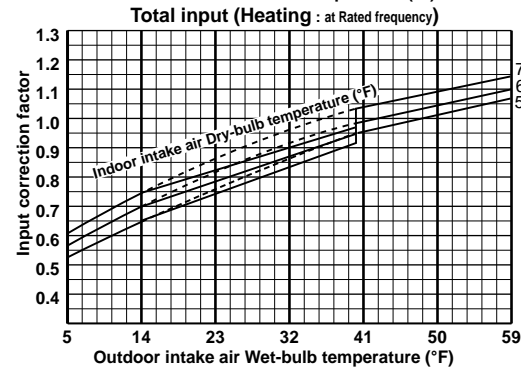
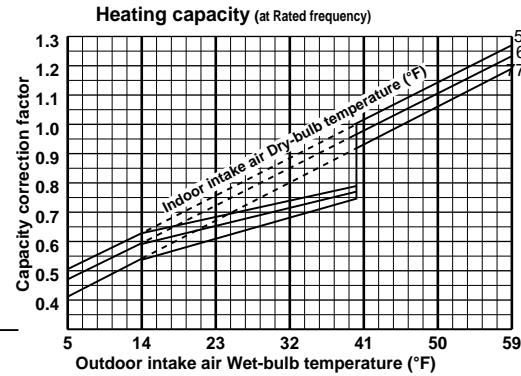

*MXZ-3C30/4C36NA

NOTE: The above broken lines are for the heating operation without any frost and defrost operation.

MXZ-5C42NA MXZ-2C20NAHZ MXZ-3C24NAHZ MXZ-3C30NAHZ

Indoor air Wet-bulb temperature difference (degree)	7.9	11.3	13.8	13.5	17.1	15.6
	7.3	10.5	12.7	12.4	15.8	14.4
	6.8	9.6	11.7	11.4	14.5	13.2
	6.2	8.8	10.7	10.5	13.2	12.1
	5.7	8.0	9.7	9.5	12.0	10.9
	5.1	7.2	8.7	8.5	10.7	9.8
	4.6	6.5	7.8	7.6	9.5	8.7
Indoor unit class (Inverter output frequency)	06 class (18Hz)	09 class (20Hz)	12 class (24Hz)	15 class (26Hz)	*1 18 class (32Hz)	*2 24 class (42Hz)

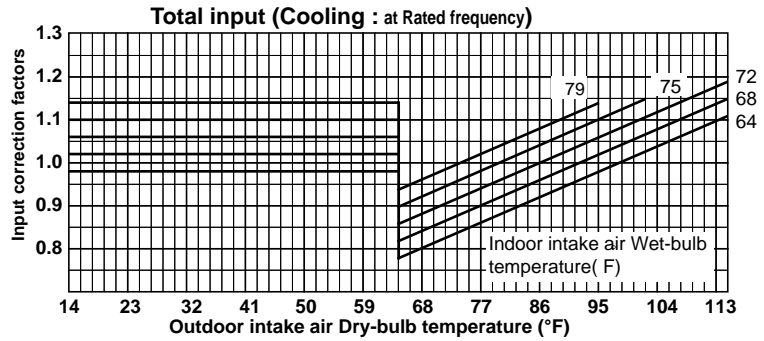
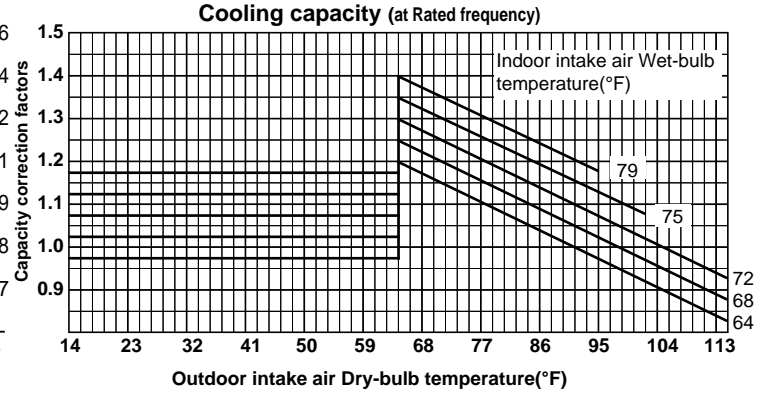

Indoor air Dry-bulb temperature difference (degree)	24.3	34.0	44.8	49.1	53.3	39.8
	22.5	31.3	41.4	45.4	49.1	36.7
	20.5	28.8	38.0	41.6	45.2	33.7
	18.5	25.7	34.0	37.4	40.5	30.2
	16.6	23.2	30.6	33.7	36.5	27.2
	14.8	20.7	27.2	29.9	32.4	24.1
	13.0	18.0	24.1	26.5	29.0	21.4
	11.0	15.3	20.2	22.1	24.1	18.0
	9.2	13.0	17.1	18.7	20.5	15.1
	7.4	10.3	13.5	14.8	16.0	11.9
Indoor unit class (Inverter output frequency)	06 class (18Hz)	09 class (20Hz)	12 class (28Hz)	15 class (33Hz)	*1 18 class (37Hz)	*2 24 class (44Hz)

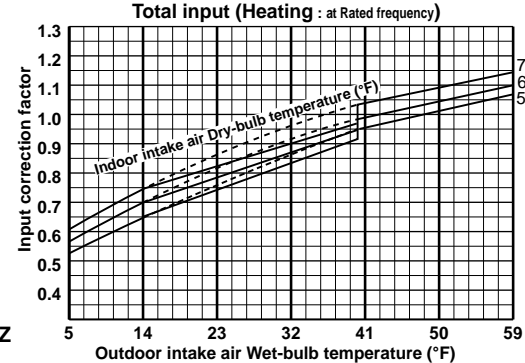
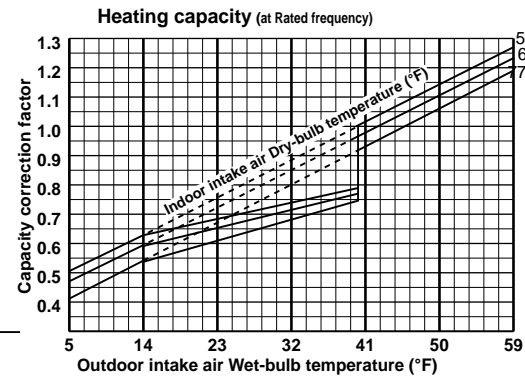

*1MXZ-5C42NA,MXZ-3C24/30NAHZ

*2MXZ-5C42NA,MXZ-3C30NAHZ

NOTE: The above broken lines are for the heating operation without any frost and defrost operation.

8-3. CAPACITY AND INPUT CORRECTION BY MEANS OF INVERTER OUTPUT FREQUENCY (OUTDOOR UNIT: MXZ-3C24NA MXZ-3C30NA MXZ-4C36NA)

1. 06-class unit in single operation

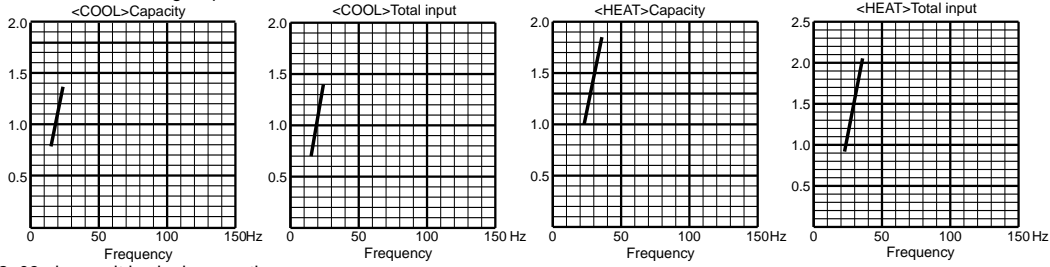

2. 09-class unit in single operation

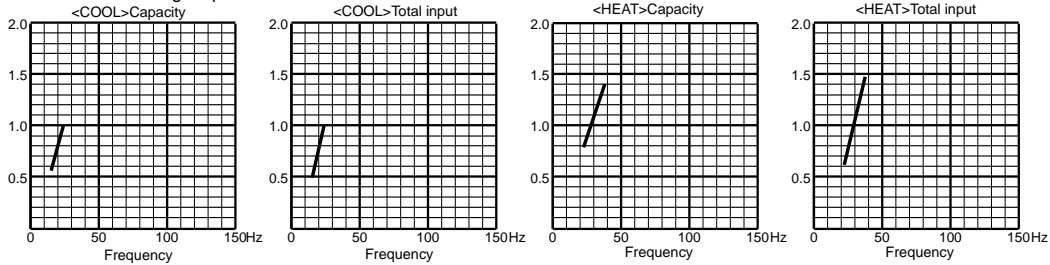

3. 12-class unit in single operation

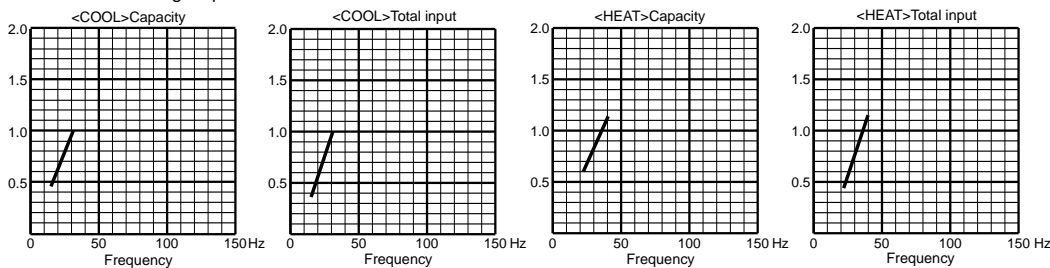

4. 15-class unit in single operation

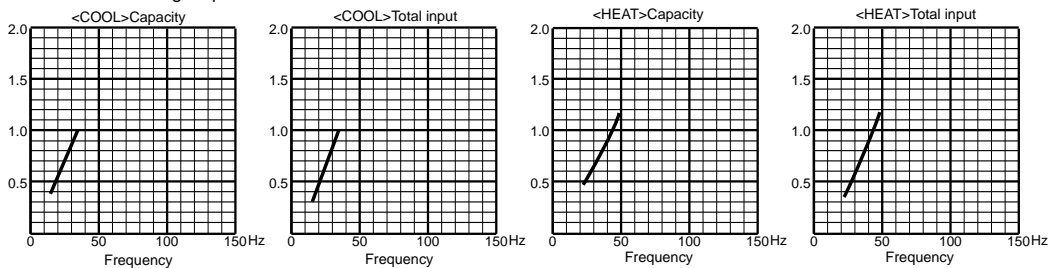

5. 18-class unit in single operation

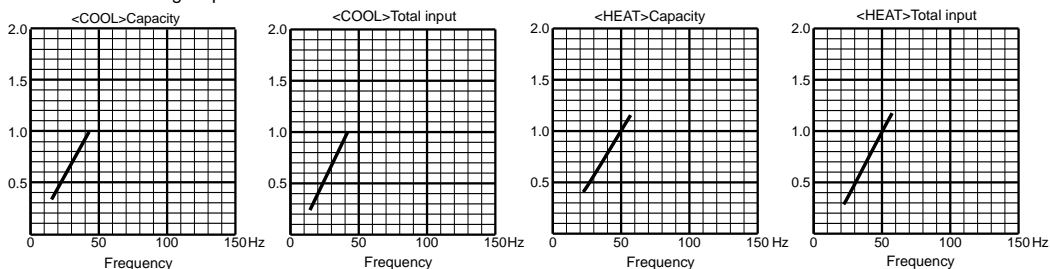

6. 24-class unit in single operation (MXZ-3C30/4C36NA only)

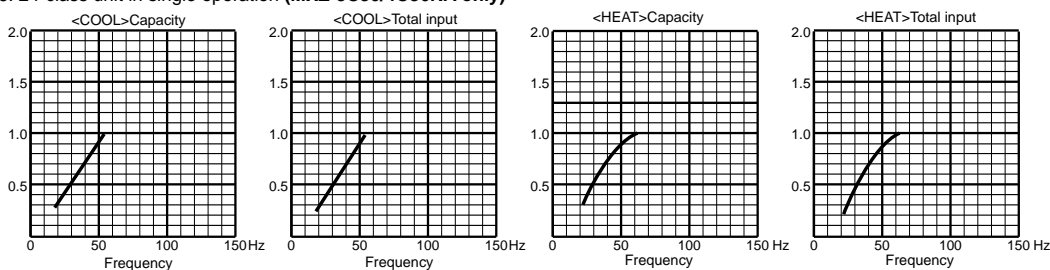

(OUTDOOR UNIT: MXZ-5C42NA MXZ-2C20NAHZ MXZ-3C24NAHZ MXZ-3C30NAHZ)

1. 06-class unit in single operation

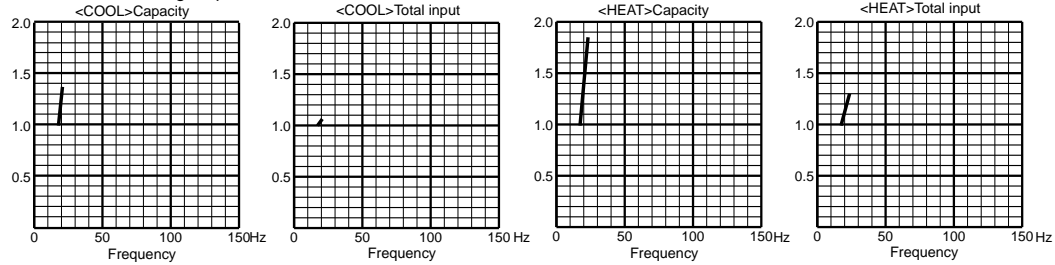

2. 09-class unit in single operation

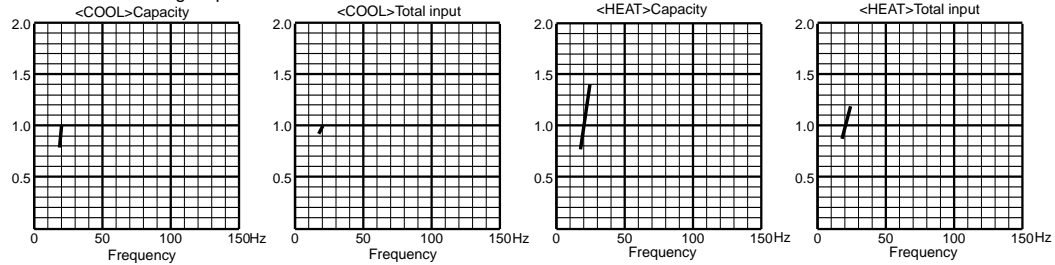

3. 12-class unit in single operation

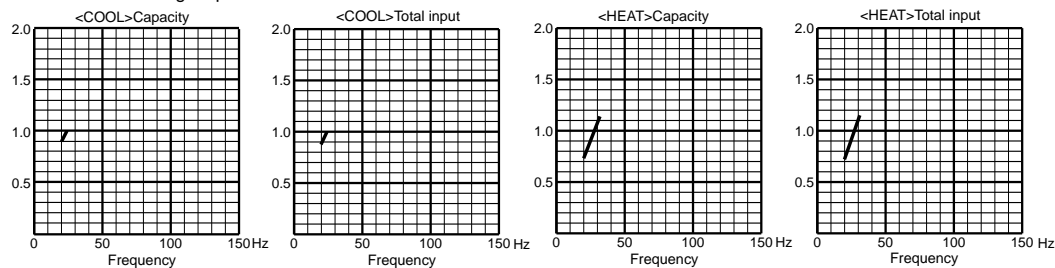

4. 15-class unit in single operation

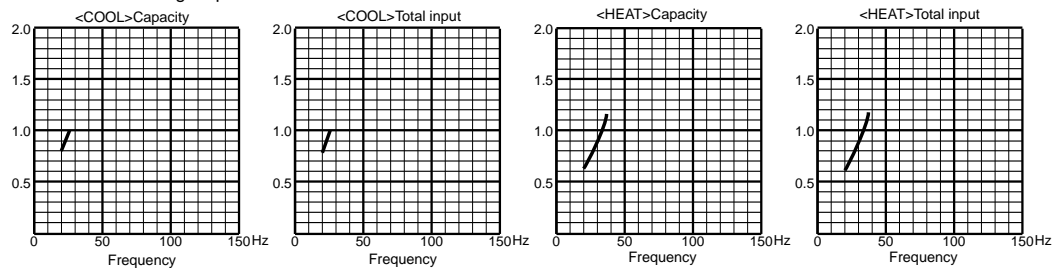

5. 18-class unit in single operation (MXZ-5C42NA, MXZ-3C24/30NAHZ only)

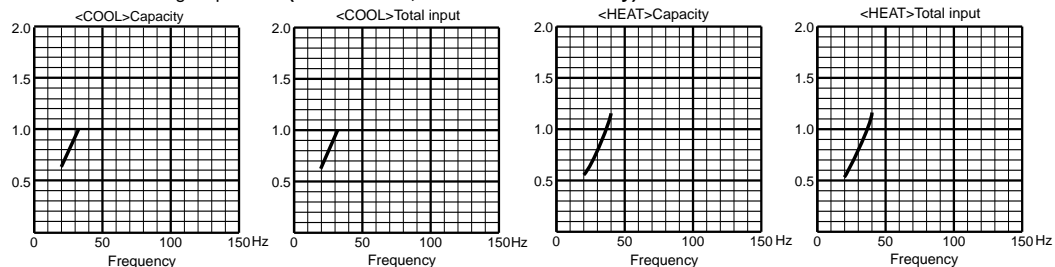

6. 24-class unit in single operation (MXZ-5C42NA, MXZ-3C30NAHZ only)

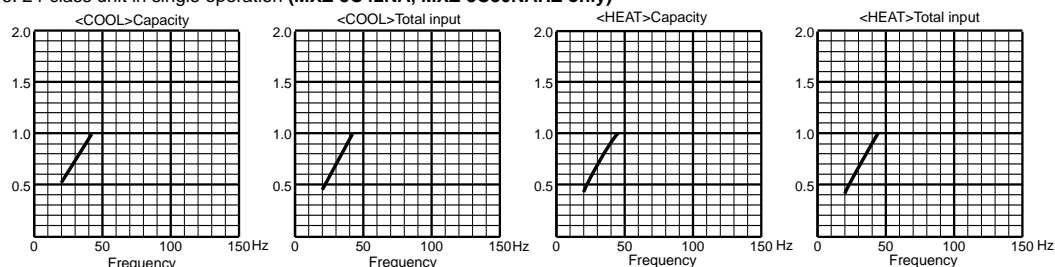

8-4. OUTDOOR LOW PRESSURE AND OUTDOOR UNIT CURRENT

1. 06-class unit in single operation (OUTDOOR UNIT : MXZ-3C24NA MXZ-3C30NA MXZ-4C36NA)

(1) COOL operation

- ① Data is based on the condition of indoor humidity 50%
- ② Air flow speed : High
- ③ Inverter output frequency : 24 Hz

<How to work fixed-frequency operation>

1. Set emergency switch to COOL or HEAT. The switch is located on indoor unit.
2. Press emergency run ON/OFF button.
3. Compressor starts running at 24 Hz (COOL) or 32 Hz (HEAT).
4. Indoor fan runs at High speed and continues for 30 minutes.
5. To cancel this operation, press emergency run ON/OFF button or any button on remote controller.

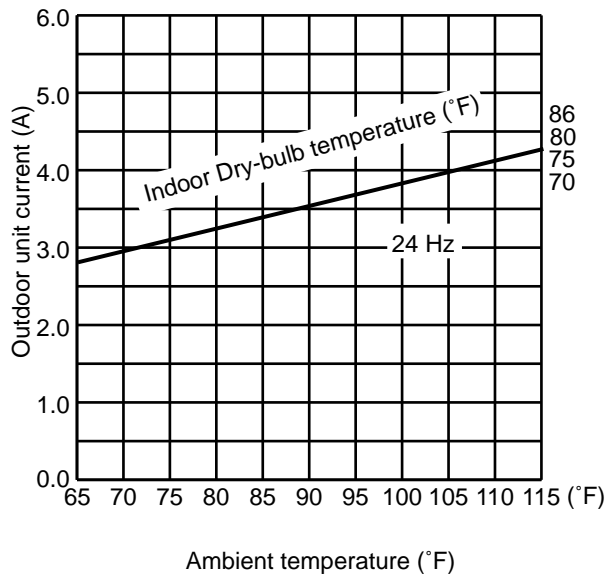
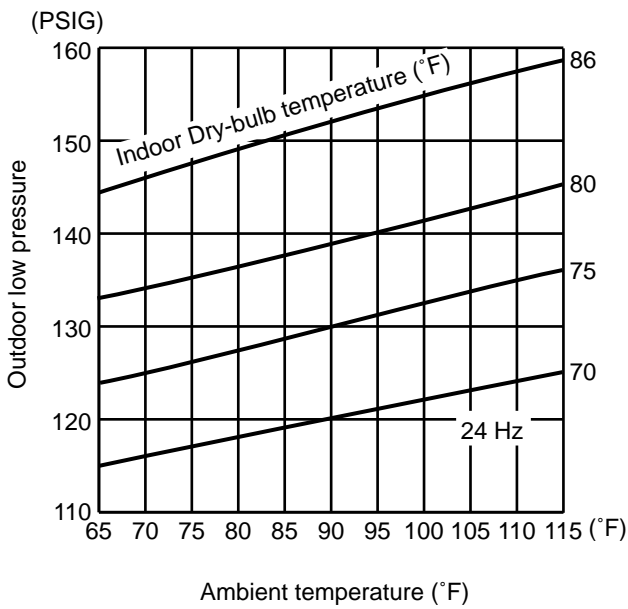

(2) HEAT operation

- ① Data is based on the condition of outdoor humidity 75%.
- ② Set air flow to High speed.
- ③ Inverter output frequency is 32 Hz.

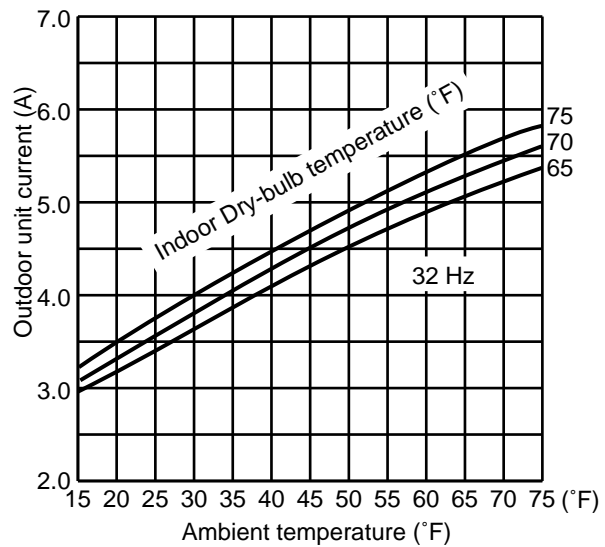

2. 09-class unit in single operation (OUTDOOR UNIT : MXZ-3C24NA MXZ-3C30NA MXZ-4C36NA)

(1) COOL operation

- ① Data is based on the condition of indoor humidity 50%
- ② Air flow speed : High
- ③ Inverter output frequency : 24 Hz

<How to work fixed-frequency operation>

1. Set emergency switch to COOL or HEAT. The switch is located on indoor unit.
2. Press emergency run ON/OFF button.
3. Compressor starts running at 24 Hz (COOL) or 32 Hz (HEAT).
4. Indoor fan runs at High speed and continues for 30 minutes.
5. To cancel this operation, press emergency run ON/OFF button or any button on remote controller.

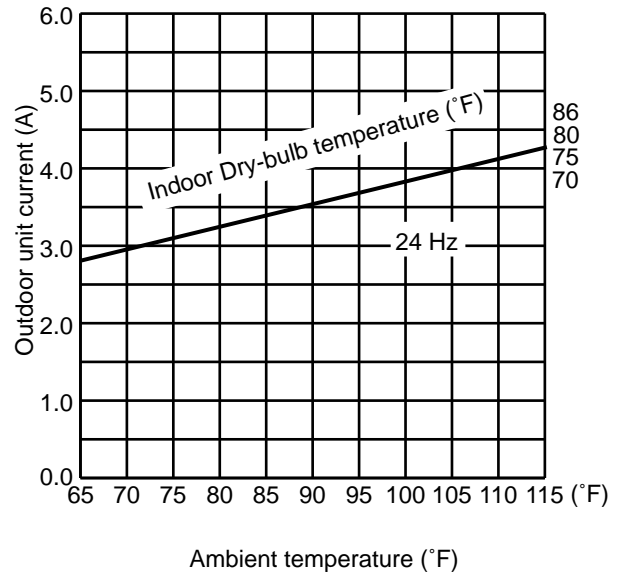
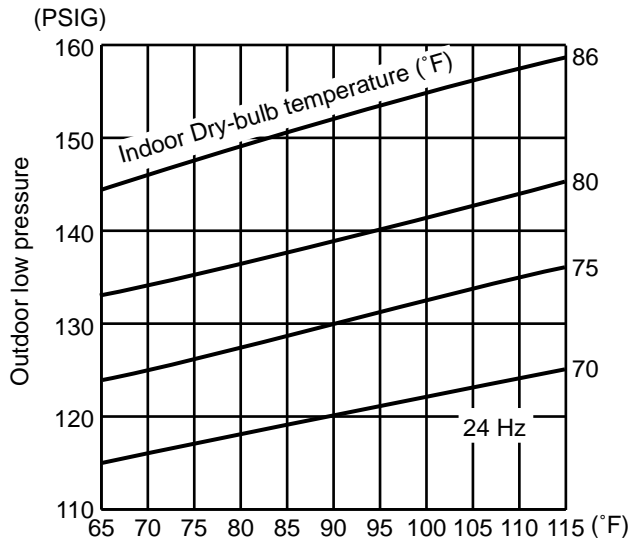

(2) HEAT operation Ambient temperature (°F)

- ① Data is based on the condition of outdoor humidity 75%.
- ② Set air flow to High speed.
- ③ Inverter output frequency is 32 Hz.

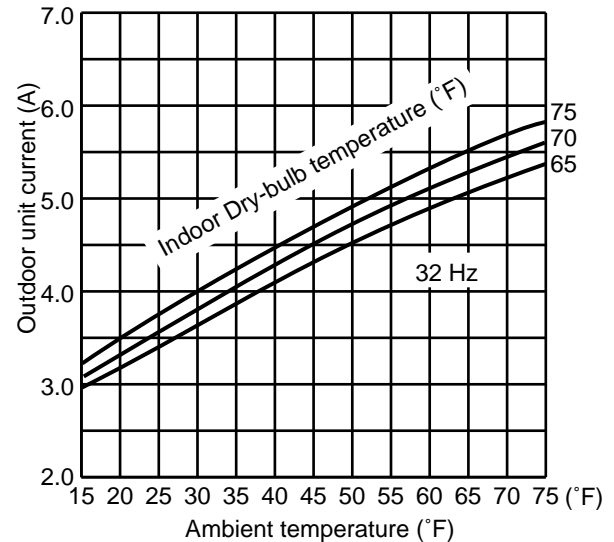

3. 12-class unit in single operation (OUTDOOR UNIT : MXZ-3C24NA MXZ-3C30NA MXZ-4C36NA)

(1) COOL operation

- ① Data is based on the condition of indoor humidity 50%
- ② Air flow speed : High
- ③ Inverter output frequency : 24 Hz

<How to work fixed-frequency operation>

1. Set emergency switch to COOL or HEAT. The switch is located on indoor unit.
2. Press emergency run ON/OFF button.
3. Compressor starts running at 24 Hz (COOL) or 32 Hz (HEAT).
4. Indoor fan runs at High speed and continues for 30 minutes.
5. To cancel this operation, press emergency run ON/OFF button or any button on remote controller.

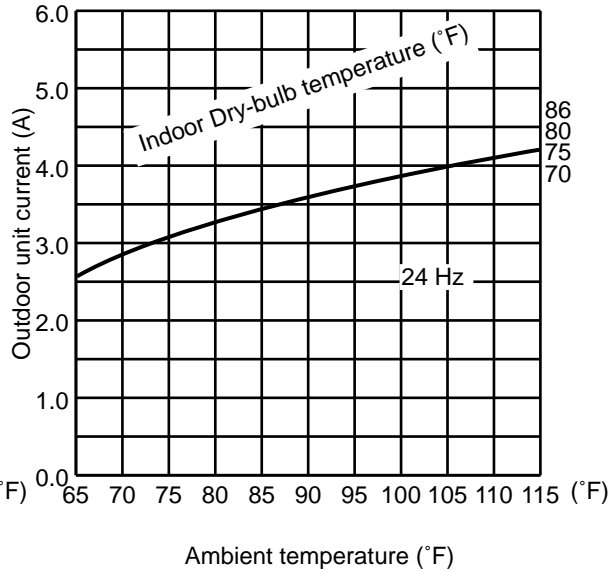
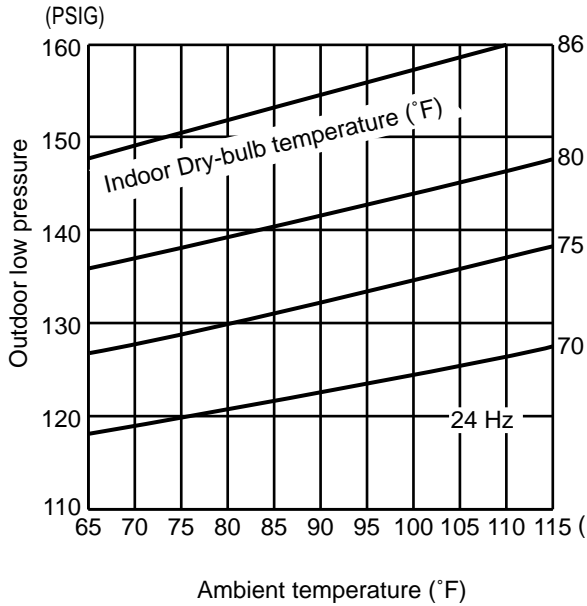

(2) HEAT operation

- ① Data is based on the condition of outdoor humidity 75%.
- ② Set air flow to High speed.
- ③ Inverter output frequency is 32 Hz.

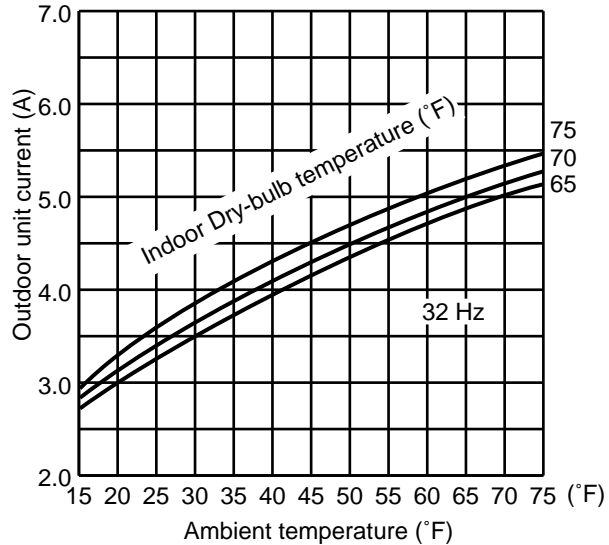

4. 15-class unit in single operation (OUTDOOR UNIT : MXZ-3C24NA MXZ-3C30NA MXZ-4C36NA)

(1) COOL operation

- ①Data is based on the condition of indoor humidity 50%
- ②Air flow speed : High
- ③Inverter output frequency : 24 Hz

<How to work fixed-frequency operation>

1. Set emergency switch to COOL or HEAT. The switch is located on indoor unit.
2. Press emergency run ON/OFF button.
3. Compressor starts running at 24 Hz (COOL) or 32 Hz (HEAT).
4. Indoor fan runs at High speed and continues for 30 minutes.
5. To cancel this operation, press emergency run ON/OFF button or any button on remote controller.

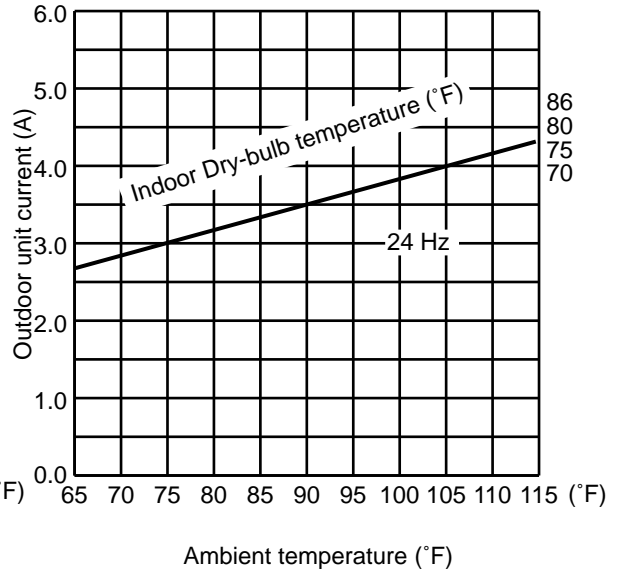
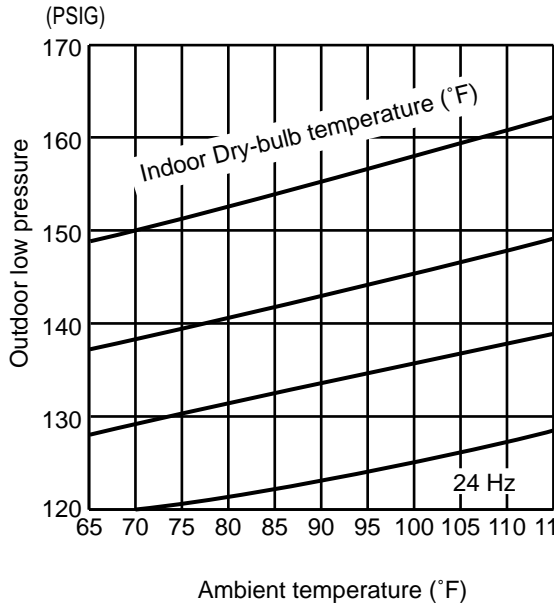

(2) HEAT operation

- ①Data is based on the condition of outdoor humidity 75%
- ②Set air flow to High speed.
- ③Inverter output frequency is 32 Hz.

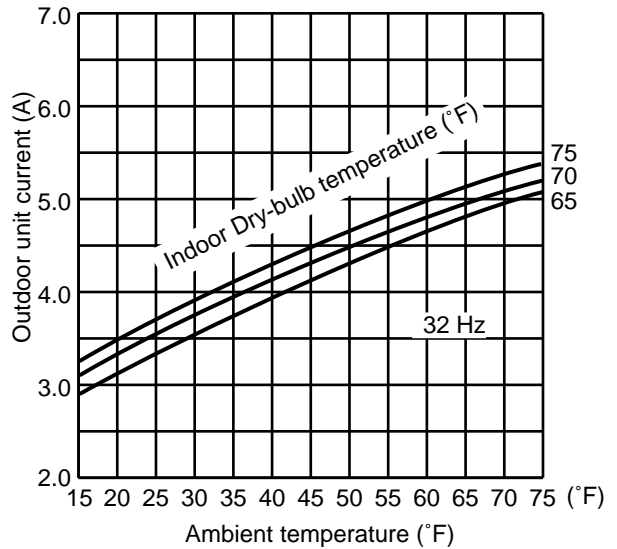

5. 18-class unit in single operation (OUTDOOR UNIT : MXZ-3C24NA MXZ-3C30NA MXZ-4C36NA)

(1) COOL operation

- ① Data is based on the condition of indoor humidity 50%
- ② Air flow speed : High
- ③ Inverter output frequency : 24 Hz

- <How to work fixed-frequency operation>
1. Set emergency switch to COOL or HEAT. The switch is located on indoor unit.
 2. Press emergency run ON/OFF button.
 3. Compressor starts running at 24 Hz (COOL) or 32 Hz (HEAT).
 4. Indoor fan runs at High speed and continues for 30 minutes.
 5. To cancel this operation, press emergency run ON/OFF button or any button on remote controller.

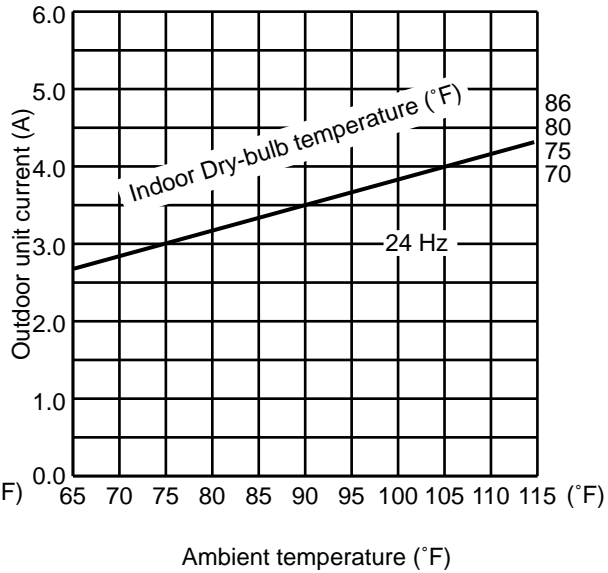
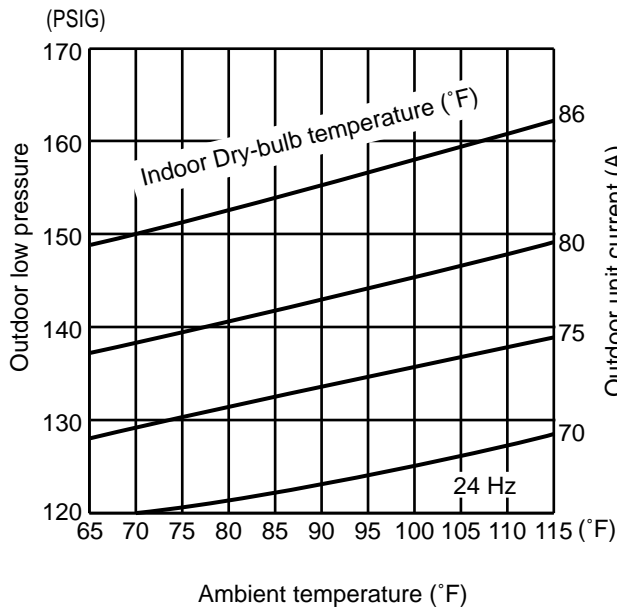

(2) HEAT operation

- ① Data is based on the condition of outdoor humidity 75%.
- ② Set air flow to High speed.
- ③ Inverter output frequency is 32 Hz.

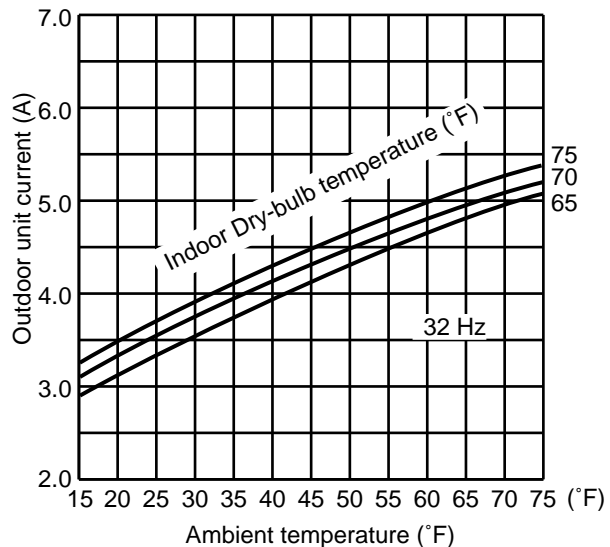

6. 24-class unit in single operation (OUTDOOR UNIT : MXZ-3C30NA MXZ-4C36NA)

(1) COOL operation

- ① Data is based on the condition of indoor humidity 50%
- ② Air flow speed : High
- ③ Inverter output frequency : 24 Hz

<How to work fixed-frequency operation>

1. Set emergency switch to COOL or HEAT. The switch is located on indoor unit.
2. Press emergency run ON/OFF button.
3. Compressor starts running at 24 Hz (COOL) or 32 Hz (HEAT).
4. Indoor fan runs at High speed and continues for 30 minutes.
5. To cancel this operation, press emergency run ON/OFF button or any button on remote controller.

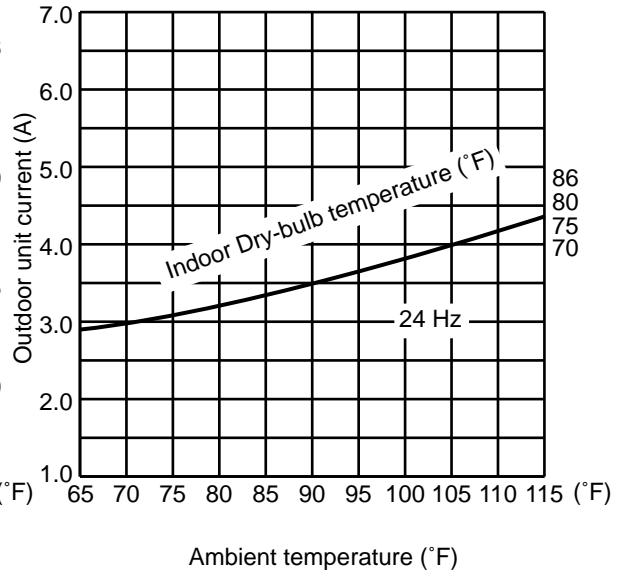
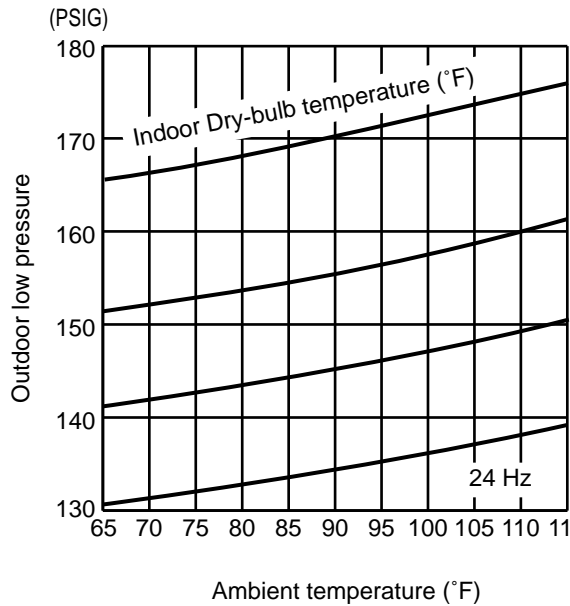

(2) HEAT operation

- ① Data is based on the condition of outdoor humidity 75%
- ② Set air flow to High speed.
- ③ Inverter output frequency is 32 Hz.

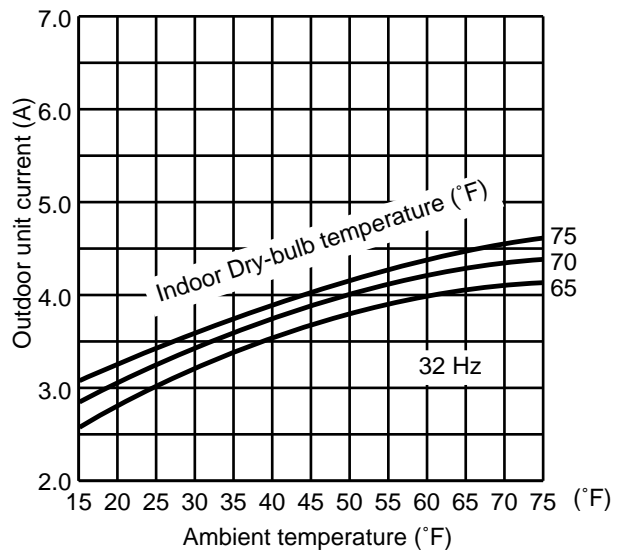

7. 06-class unit in single operation
(OUTDOOR UNIT : MXZ-5C42NA MXZ-2C20NAHZ MXZ-3C24NAHZ MXZ-3C30NAHZ)

(1) COOL operation

- ① Data is based on the condition of indoor humidity 50%
- ② Air flow speed : High
- ③ Inverter output frequency : 18 Hz

<How to work fixed-frequency operation>

1. Set emergency switch to COOL or HEAT. The switch is located on indoor unit.
2. Press emergency run ON/OFF button.
3. Compressor starts running at 18 Hz (COOL) or 20 Hz (HEAT).
4. Indoor fan runs at High speed and continues for 30 minutes.
5. To cancel this operation, press emergency run ON/OFF button or any button on remote controller.

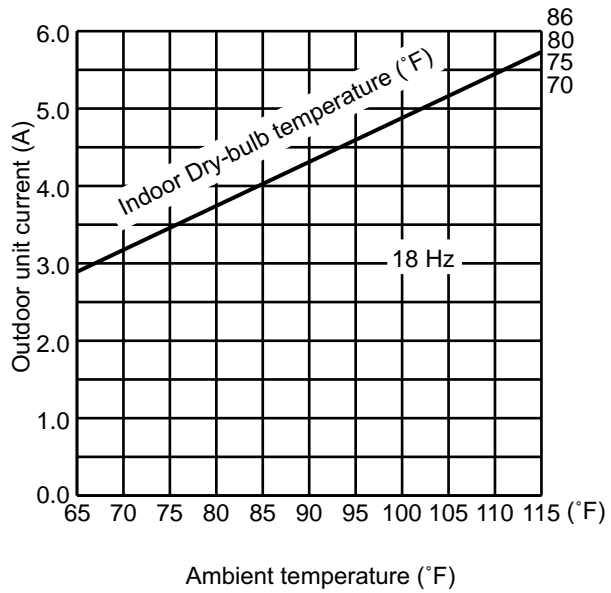
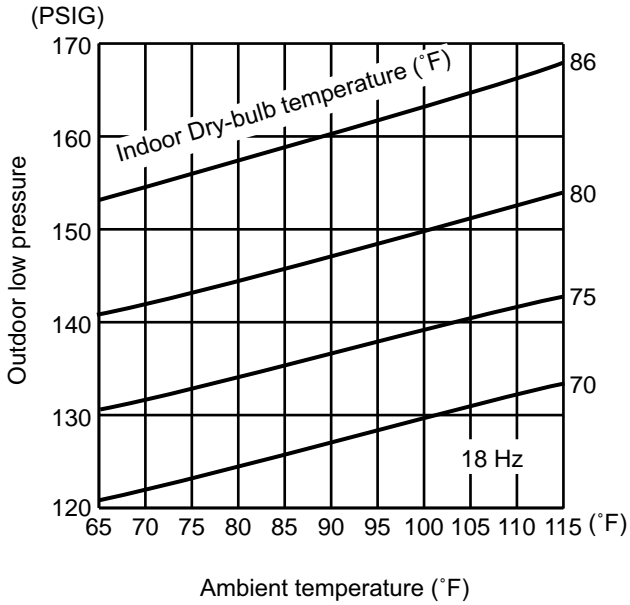

(2) HEAT operation

- ① Data is based on the condition of outdoor humidity 75%.
- ② Set air flow to High speed.
- ③ Inverter output frequency is 20 Hz.

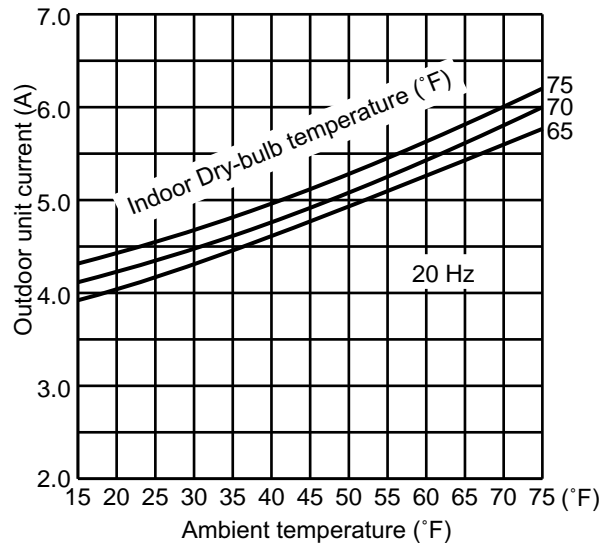

8. 09-class unit in single operation

(OUTDOOR UNIT : MXZ-5C42NA MXZ-2C20NAHZ MXZ-3C24NAHZ MXZ-3C30NAHZ)

(1) COOL operation

- ①Data is based on the condition of indoor humidity 50%
- ②Air flow speed : High
- ③Inverter output frequency : 18 Hz

<How to work fixed-frequency operation>

1. Set emergency switch to COOL or HEAT. The switch is located on indoor unit.
2. Press emergency run ON/OFF button.
3. Compressor starts running at 18 Hz (COOL) or 20 Hz (HEAT).
4. Indoor fan runs at High speed and continues for 30 minutes.
5. To cancel this operation, press emergency run ON/OFF button or any button on remote controller.

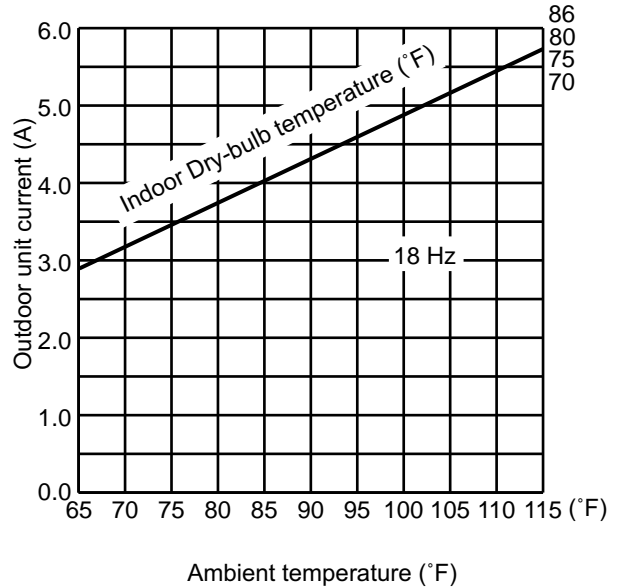
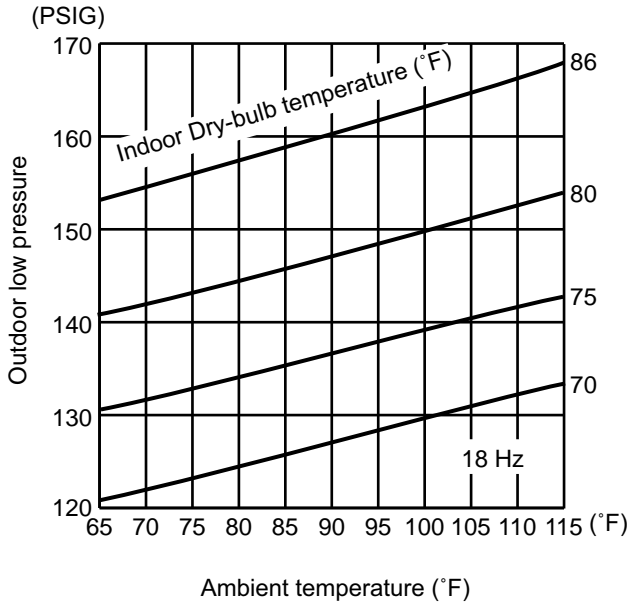

(2) HEAT operation

- ①Data is based on the condition of outdoor humidity 75%.
- ②Set air flow to High speed.
- ③Inverter output frequency is 20 Hz.

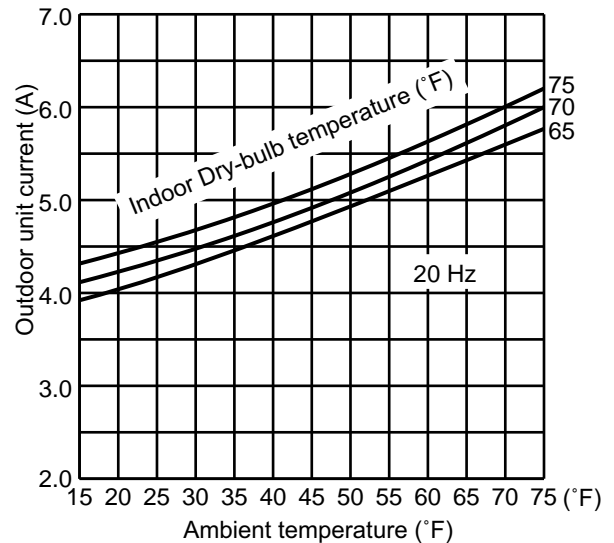

9. 12-class unit in single operation

(OUTDOOR UNIT : MXZ-5C42NA MXZ-2C20NAHZ MXZ-3C24NAHZ MXZ-3C30NAHZ)

(1) COOL operation

- ① Data is based on the condition of indoor humidity 50%
- ② Air flow speed : High
- ③ Inverter output frequency : 18 Hz

<How to work fixed-frequency operation>

1. Set emergency switch to COOL or HEAT. The switch is located on indoor unit.
2. Press emergency run ON/OFF button.
3. Compressor starts running at 18 Hz (COOL) or 20 Hz (HEAT).
4. Indoor fan runs at High speed and continues for 30 minutes.
5. To cancel this operation, press emergency run ON/OFF button or any button on remote controller.

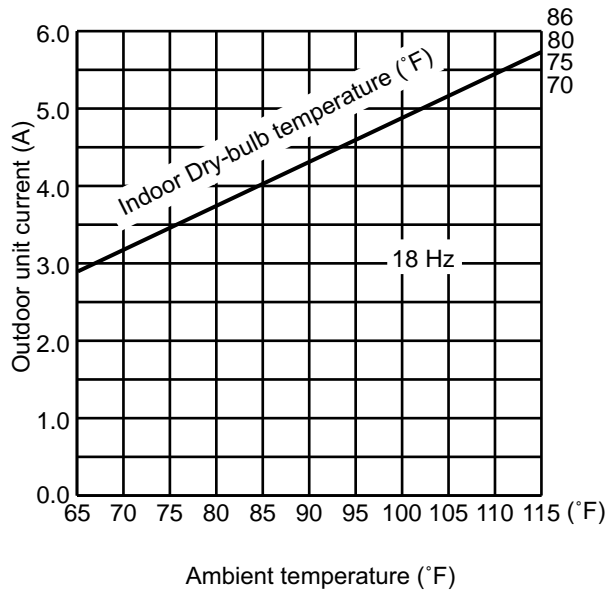
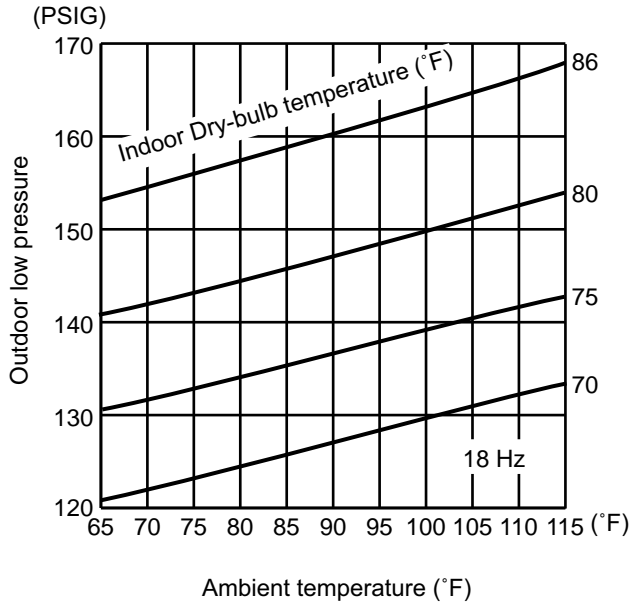

(2) HEAT operation

- ① Data is based on the condition of outdoor humidity 75%.
- ② Set air flow to High speed.
- ③ Inverter output frequency is 20 Hz.

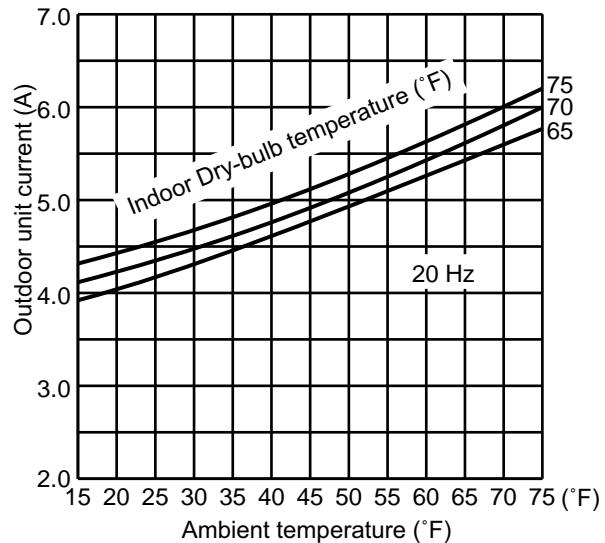

10. 15-class unit in single operation

(OUTDOOR UNIT : MXZ-5C42NA MXZ-2C20NAHZ MXZ-3C24NAHZ MXZ-3C30NAHZ)

(1) COOL operation

- ①Data is based on the condition of indoor humidity 50%
- ②Air flow speed : High
- ③Inverter output frequency : 18 Hz

<How to work fixed-frequency operation>

1. Set emergency switch to COOL or HEAT. The switch is located on indoor unit.
2. Press emergency run ON/OFF button.
3. Compressor starts running at 18 Hz (COOL) or 20 Hz (HEAT).
4. Indoor fan runs at High speed and continues for 30 minutes.
5. To cancel this operation, press emergency run ON/OFF button or any button on remote controller.

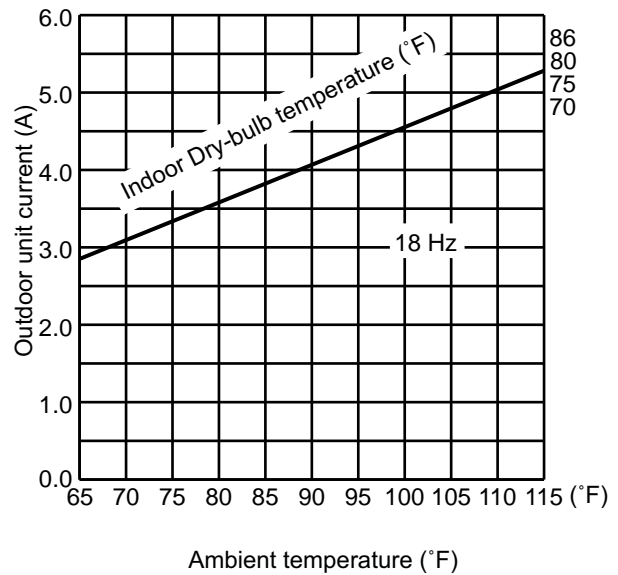
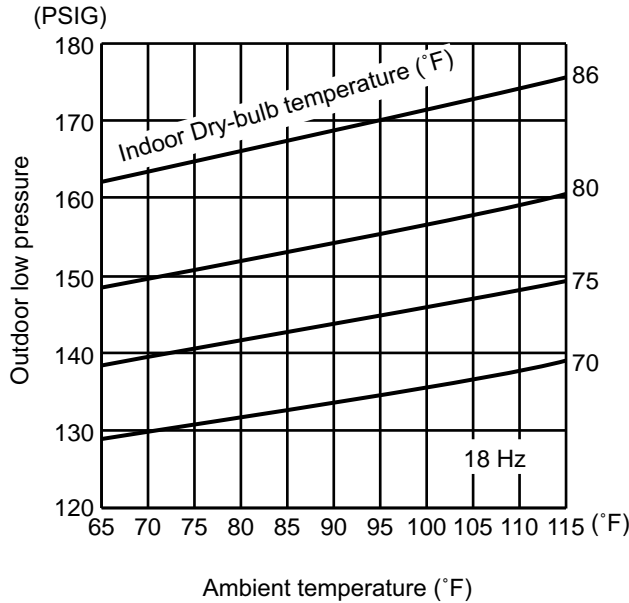

(2) HEAT operation

- ①Data is based on the condition of outdoor humidity 75%.
- ②Set air flow to High speed.
- ③Inverter output frequency is 20 Hz.

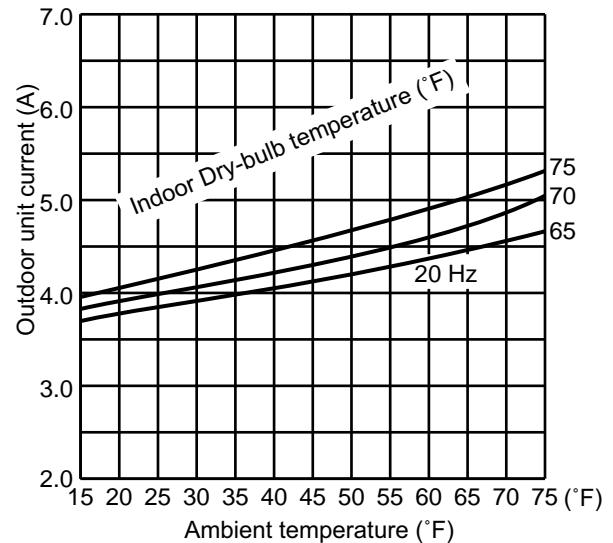

11. 18-class unit in single operation
(OUTDOOR UNIT : MXZ-5C42NA MXZ-3C24NAHZ MXZ-3C30NAHZ)

(1) COOL operation

- ① Data is based on the condition of indoor humidity 50%
- ② Air flow speed : High
- ③ Inverter output frequency : 18 Hz

<How to work fixed-frequency operation>

1. Set emergency switch to COOL or HEAT. The switch is located on indoor unit.
2. Press emergency run ON/OFF button.
3. Compressor starts running at 18 Hz (COOL) or 20 Hz (HEAT).
4. Indoor fan runs at High speed and continues for 30 minutes.
5. To cancel this operation, press emergency run ON/OFF button or any button on remote controller.

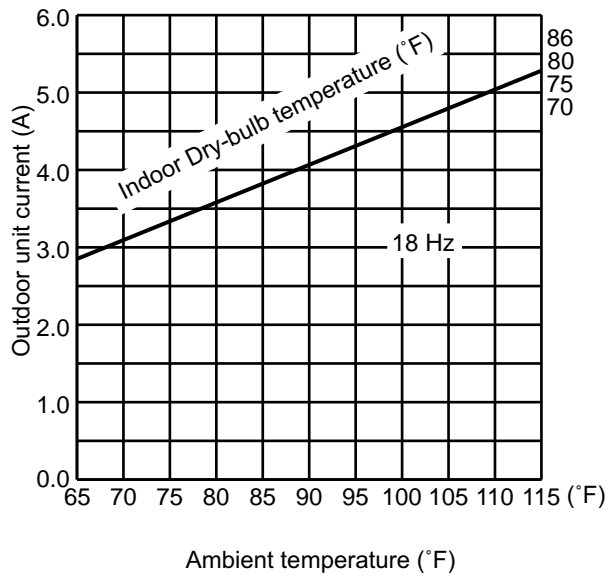
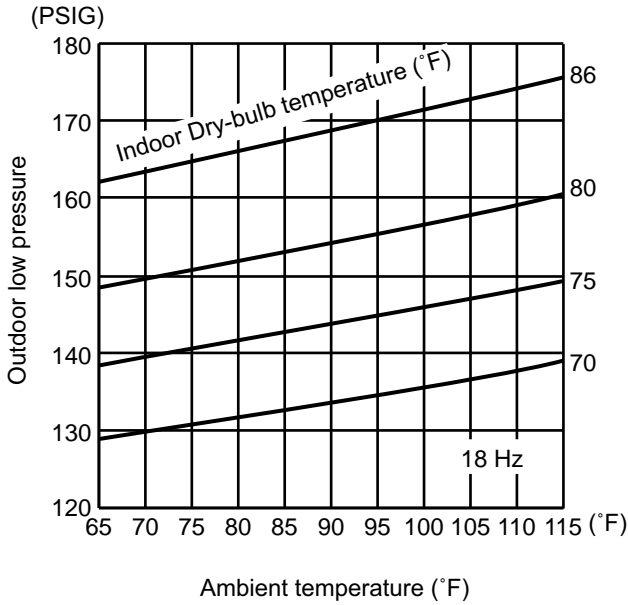

(2) HEAT operation

- ① Data is based on the condition of outdoor humidity 75%.
- ② Set air flow to High speed.
- ③ Inverter output frequency is 20 Hz.

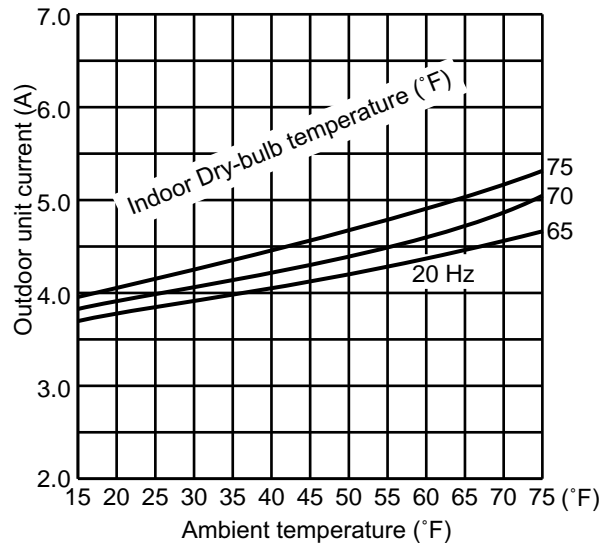

12. 24-class unit in single operation
(OUTDOOR UNIT : MXZ-5C42NA MXZ-3C30NAHZ)

(1) COOL operation

- ①Data is based on the condition of indoor humidity 50%
- ②Air flow speed : High
- ③Inverter output frequency : 18 Hz

<How to work fixed-frequency operation>

1. Set emergency switch to COOL or HEAT. The switch is located on indoor unit.
2. Press emergency run ON/OFF button.
3. Compressor starts running at 18 Hz (COOL) or 20 Hz (HEAT).
4. Indoor fan runs at High speed and continues for 30 minutes.
5. To cancel this operation, press emergency run ON/OFF button or any button on remote controller.

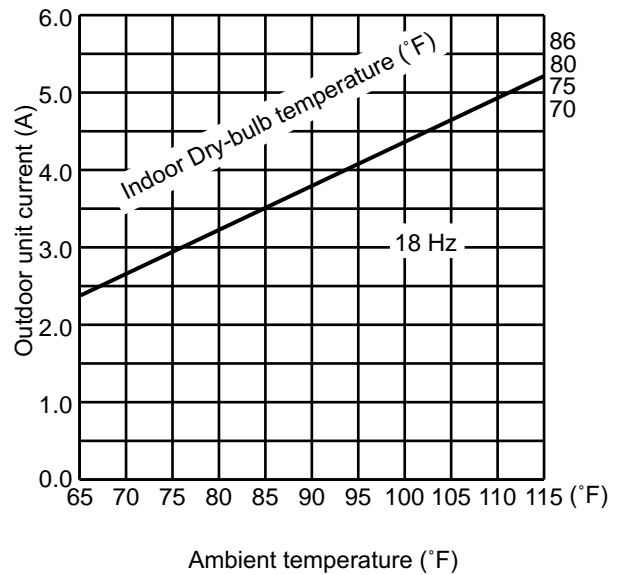
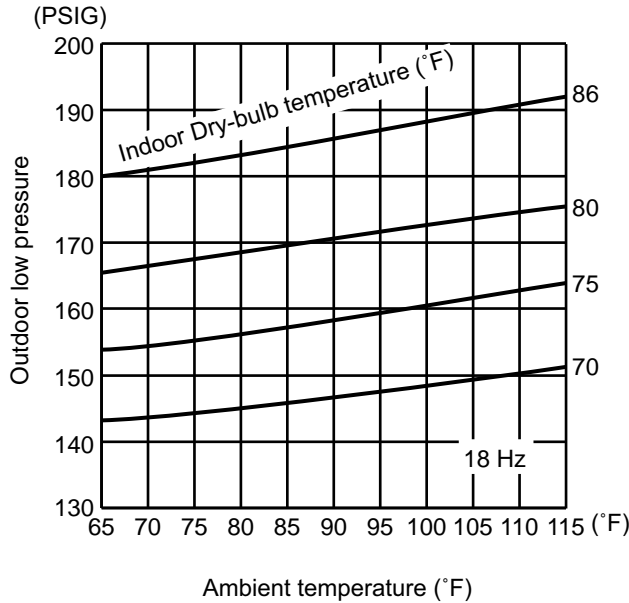

(2) HEAT operation

- ①Data is based on the condition of outdoor humidity 75%.
- ②Set air flow to High speed.
- ③Inverter output frequency is 20 Hz.

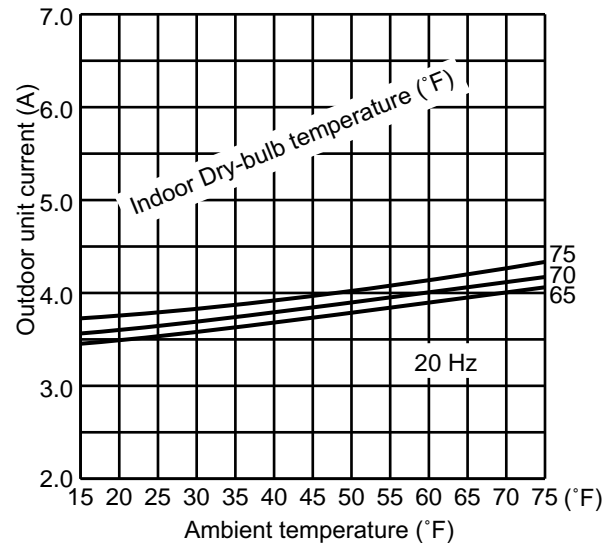

MXZ-3C24NA MXZ-3C30NA MXZ-4C36NA MXZ-5C42NA
MXZ-2C20NAHZ MXZ-3C24NAHZ MXZ-3C30NAHZ

Relation between main sensor and actuator

Sensor	Purpose	Actuator					
		Compressor	LEV	Outdoor fan motor	4-way valve	2-way solenoid valve	Defrost heater
						(MXZ-5C42VA MXZ-2C20NAHZ MXZ-3C24NAHZ MXZ-3C30NAHZ)	(MXZ-2C20NAHZ MXZ-3C24NAHZ MXZ-3C30NAHZ)
Discharge temperature thermistor	Protection	○	○			○	
Indoor coil temperature thermistor	Cooling: Coil frost prevention	○				○	
	Heating: High pressure protection	○	○				
Defrost thermistor	Heating: Defrosting	○	○	○	○		
Fin temperature thermistor	Protection	○		○			
Ambient temperature thermistor	Control/Protection	○	○	○		○	
	Heating: Defrosting (Heater)						○
Outdoor heat exchanger temperature thermistor	Cooling: Control/Protection	○	○	○		○	
Capacity code	Control	○	○				

MXZ-3C24NA MXZ-3C30NA MXZ-4C36NA MXZ-5C42NA
MXZ-2C20NAHZ MXZ-3C24NAHZ MXZ-3C30NAHZ

10-1. PRE-HEAT CONTROL

If moisture gets into the refrigerant cycle, or when refrigerant is liquefied and collected in the compressor, it may interfere the start-up of the compressor.

To improve start-up condition, the compressor is energized even while it is not operating.

This is to generate heat at the winding.

The compressor uses about 50 W when pre-heat control is turned ON.

Pre-heat control is ON at initial setting.

[How to deactivate pre-heat control]

- ① Turn OFF the power supply for the air conditioner before making the setting.
- ② Set the "4" of SW2 on the outdoor control P.C. board to ON to deactivate pre-heat control function.

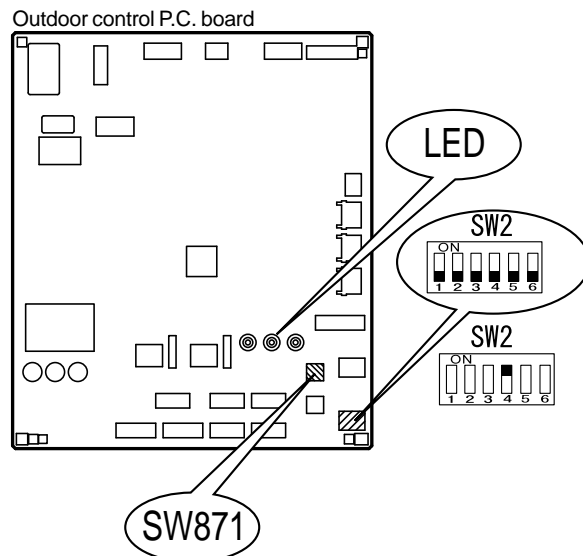

- ③ Turn ON the power supply for the air conditioner.

NOTE: Pre-heat control will be turned OFF when the breaker is turned OFF.

10-2. AUTO LINE CORRECTING

Outdoor unit has an auto line correcting function which automatically detects and corrects improper wiring or piping.

Improper wiring or piping can be automatically detected by pressing the piping/wiring correction switch (SW871). When improper wiring or piping is detected, wiring lines are corrected. This will be completed in about 10 to 20 minutes.

[How to activate this function]

1. Check that outside temperature is above 32°F.
(This function does not work when outside temperature is not above 32°F.)
2. Check that the stop valves of the liquid pipe and gas pipe are open.
3. Check that the wiring between indoor and outdoor unit is correct.
(If the wiring is not correct, this function does not work.)
4. Turn ON the power supply and wait at least 1 minute.
5. Press the piping/wiring correction switch (SW871) on the outdoor control P.C. board.
Do not touch energized parts.

LED indication during detection:

LED1 (Red)	LED2 (Yellow)	LED3 (Green)
Lighted	Lighted	Once

LED indication after detection:

LED1 (Red)	LED2 (Yellow)	LED3 (Green)	Indication
Lighted	Not lighted	Lighted	Completed (Problem corrected/ normal)
Once	Once	Once	Not completed (Detection failed)
Other indications			Refer to "SAFETY PRECAUTIONS WHEN LED FLASHES" located behind the service panel.

* Make sure that the valves are open and the pipes are not collapsed or clogged.

6. Press the switch to cancel.

LED indication after cancel :

LED1 (Red)	LED2 (Yellow)	LED3 (Green)
Lighted	Lighted	Not lighted

NOTE : Indoor unit cannot be operated while this function is activated.

When this function is activated while indoor unit is operating, the operation will be stopped.

Operate indoor unit after the auto line correcting is finished.

Pressing the switch during detection cancels this function.

The record of auto line correcting can be confirmed in the following way:

Press the switch for more than 5 seconds.

LED will show the record of auto correcting for about 30 seconds as shown in the table below:

Number of blinks			Wiring line
LED1 (Red)	LED2 (Yellow)	LED3 (Green)	
Once	Once	Lighted	Not corrected
3 times	3 times	Lighted	Corrected

NOTE : Activate this function to confirm the correct wiring after replacing the outdoor control P.C. board.

(Previous records are deleted when the outdoor control P.C. board is replaced.)

The record cannot be shown if auto line correcting is not canceled (Refer to "How to activate this function").

MXZ-3C24NA MXZ-3C30NA MXZ-4C36NA MXZ-5C42NA
MXZ-2C20NAHZ MXZ-3C24NAHZ MXZ-3C30NAHZ

11-1. CAUTIONS ON TROUBLESHOOTING

1. Before troubleshooting, check the following:

- 1) Check the power supply voltage.
- 2) Check the indoor/outdoor connecting wire for miswiring.

2. Take care of the following during servicing.

- 1) Before servicing the air conditioner, be sure to turn OFF the unit first with the remote controller, and then after confirming the horizontal vane is closed, turn OFF the breaker and/or disconnect the power plug.
- 2) Be sure to turn OFF the power supply before removing the front panel, the cabinet, the top panel, and the outdoor control P.C. board.
- 3) When removing the electrical parts, be careful of the residual voltage of smoothing capacitor.
- 4) When removing the electronic control P.C. board, hold the edge of the board with care NOT to apply stress on the components.
- 5) When connecting or disconnecting the connectors, hold the connector housing. DO NOT pull the lead wires.

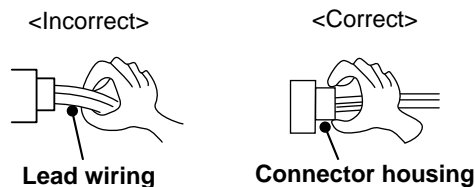

3. Troubleshooting procedure

- 1) Check if the OPERATION INDICATOR lamp on the indoor unit is flashing on and off to indicate an abnormality. To make sure, check how many times the OPERATIONAL INDICATOR lamp is flashing on and off before starting service work.
- 2) When the outdoor control P.C. board seems to be defective, check the copper foil pattern for disconnection and the components for bursting and discoloration.
- 3) When troubleshooting, refer to 11-2, 11-3 and 11-4.

11-2. FAILURE MODE RECALL FUNCTION

This air conditioner can memorize the abnormal condition which has occurred once.

Even though LED indication listed on the troubleshooting check table (11-4) disappears, the memorized failure details can be recalled.

1. Flow chart of failure mode recall function for the indoor/outdoor unit

Refer to the service manual of indoor unit.

2. Flow chart of the detailed outdoor unit failure mode recall function

Operational procedure

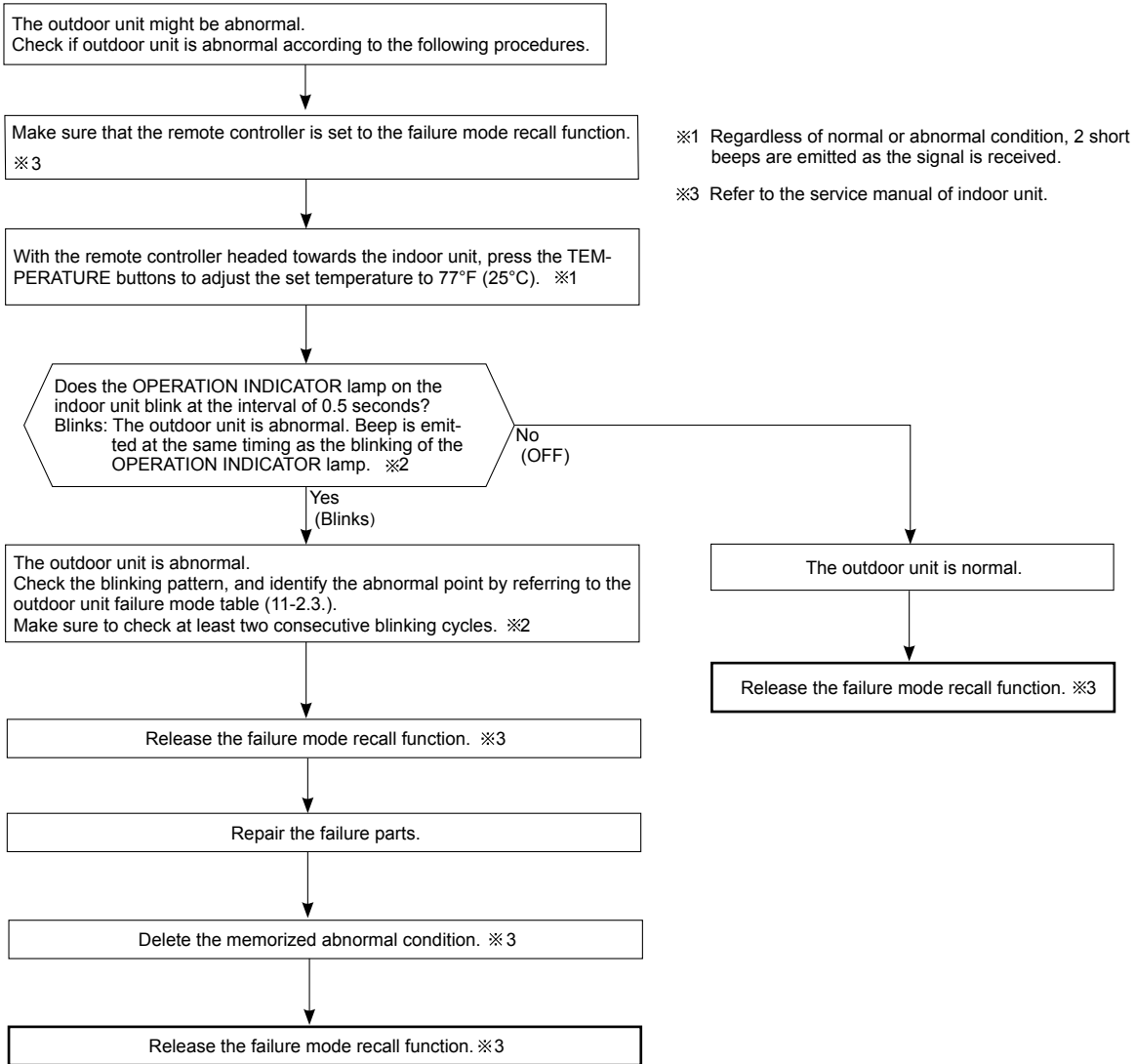

NOTE: 1. Make sure to release the failure mode recall function after it is set up, otherwise the unit cannot operate properly.
2. If the abnormal condition is not deleted from the memory, the last abnormal condition is kept memorized.

※2. Blinking pattern when outdoor unit is abnormal:

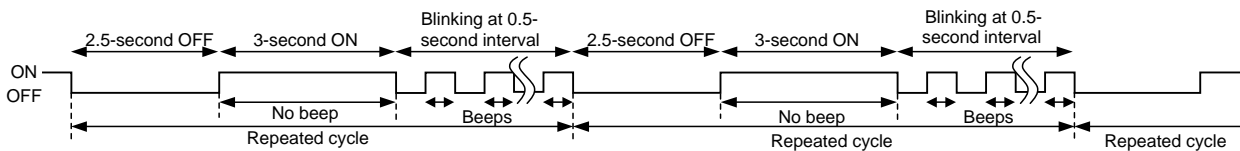

3. Outdoor unit failure mode table

The left lamp of OPERATION INDICATOR lamp (Indoor unit)	Abnormal point (Failure mode/protection)	LED indication (Outdoor P.C. board)		Condition	Remedy	Indoor/outdoor unit failure mode recall function
		LED 1	LED 2			
OFF	None (Normal)	Lighted	Lighted			
2-time flash	Outdoor power system	Lighted	Lighted	Overcurrent protection cut-out operates 3 consecutive times within 1 minute after the compressor gets started, or converter protection cut-out or bus-bar voltage protection cut-out operates 3 consecutive times within 3 minutes after start-up.	<ul style="list-style-type: none"> Check the connection of the compressor connecting wire. Refer to 11-6. ⑤ "How to check inverter/compressor". Check the stop valve. 	○
3-time flash	Discharge temperature thermistor	Lighted	Once	A thermistor shorts or opens during compressor running.	<ul style="list-style-type: none"> Refer to 11-6. ⑤ "Check of outdoor thermistors". 	○
	Defrost thermistor	Lighted	Once			
	Ambient temperature thermistor	Lighted	Twice			
	Fin temperature thermistor	Lighted	3 times			
	P.C. board temperature thermistor	Lighted	4 times			
Outdoor heat exchanger temperature thermistor	Lighted	9 times		<ul style="list-style-type: none"> Replace the outdoor control P.C. board. Refer to 11-6. ⑤ "Check of outdoor thermistors". 		
4-time flash	Overcurrent	Once	Not lighted	21 A (MXZ-3C24/3C30/4C36NA)/28 A (MXZ-5C42NA, 2C20/3C24/3C30NAHZ) current flows into power module.	<ul style="list-style-type: none"> Reconnect compressor connector. Refer to 11-6. ⑤ "How to check inverter/compressor". Check the stop valve. 	—
5-time flash	Discharge temperature	Lighted	Lighted	The discharge temperature exceeds 240.8 °F during operation. Compressor can restart if discharge temperature thermistor reads 212 °F or less 3 minutes later.	<ul style="list-style-type: none"> Check refrigerant circuit and refrigerant amount. Refer to 11-6. ⑤ "Check of LEV". 	—
6-time flash	High pressure	Lighted	Lighted	The outdoor heat exchanger temperature exceeds 158°F during cooling or the indoor gas pipe temperature exceeds 158 °F during heating.	<ul style="list-style-type: none"> Check refrigerant circuit and refrigerant amount. Check the stop valve. 	—
7-time flash	Fin temperature	3 times	Not lighted	The fin temperature exceeds 192 °F during operation.	<ul style="list-style-type: none"> Check around outdoor unit. Check outdoor unit air passage. Refer to 11-6. ⑤ "Check of outdoor fan motor". 	—
	P.C. board temperature	4 times	Not lighted	The P.C. board temperature exceeds 189 °F during operation.		
8-time flash	Outdoor fan motor	Lighted	Lighted	A failure occurs 3 consecutive times within 30 seconds after the fan gets started.	<ul style="list-style-type: none"> Refer to 11-6. ⑤ "Check of outdoor fan motor". 	—
9-time flash	Outdoor control system	Lighted	5 times	Nonvolatile memory data cannot be read properly.	<ul style="list-style-type: none"> Replace the outdoor control P.C. board. 	○
10-time flash	Low discharge temperature protection	Lighted	Lighted	The frequency of the compressor is kept 80 Hz or more and the discharge temperature is kept under 102.2 °F for more than 20 minutes.	<ul style="list-style-type: none"> Check refrigerant circuit and refrigerant amount. Refer to 11-6. ⑤ "Check of LEV". 	—
11-time flash	Communication error between P.C. boards	Lighted	6 times	Communication error occurs between the outdoor control P.C. board and outdoor power P.C. board for more than 10 seconds.	<ul style="list-style-type: none"> Check the connecting wire between outdoor control P.C. board and outdoor power P.C. board. 	—
				The communication between boards protection cut-out operates 2 consecutive times.		○
	Current sensor	Lighted	7 times	A short or open circuit is detected in the current sensor during compressor operating.	—	—
				Current sensor protection cut-out operates 2 consecutive times.		○
	Zero cross detecting circuit	5 times	Not lighted	Zero cross signal cannot be detected while the compressor is operating.	<ul style="list-style-type: none"> Check the connecting wire among outdoor control P.C. board and outdoor power P.C. board. 	—
				The protection cut-out of the zero cross detecting circuit operates 10 consecutive times.		○
Converter	5 times	Not lighted	A failure is detected in the operation of the converter during operation.	<ul style="list-style-type: none"> Check the voltage of power supply. Replace the outdoor power P.C. board. 	—	
Bus-bar voltage	6 times	Not lighted	The bus-bar voltage exceeds 400 V or falls to low level during compressor operating.	<ul style="list-style-type: none"> Check the voltage of power supply. Replace the outdoor control P.C. board. 	—	
15-time flash	LEV and drain pump	Lighted	Lighted	The indoor unit detects an abnormality in the LEV and drain pump.	<ul style="list-style-type: none"> Refer to 11-6. ⑤ "Check of LEV". Check the drain pump of the indoor unit. 	—

NOTE: Blinking patterns of this mode differ from the ones of Troubleshooting check table (11-4.).

11-3. INSTRUCTION OF TROUBLESHOOTING

- Check the indoor unit with referring to the indoor unit service manual, and confirm that there is any problem in the indoor unit.
Then, check the outdoor unit with referring to this page.

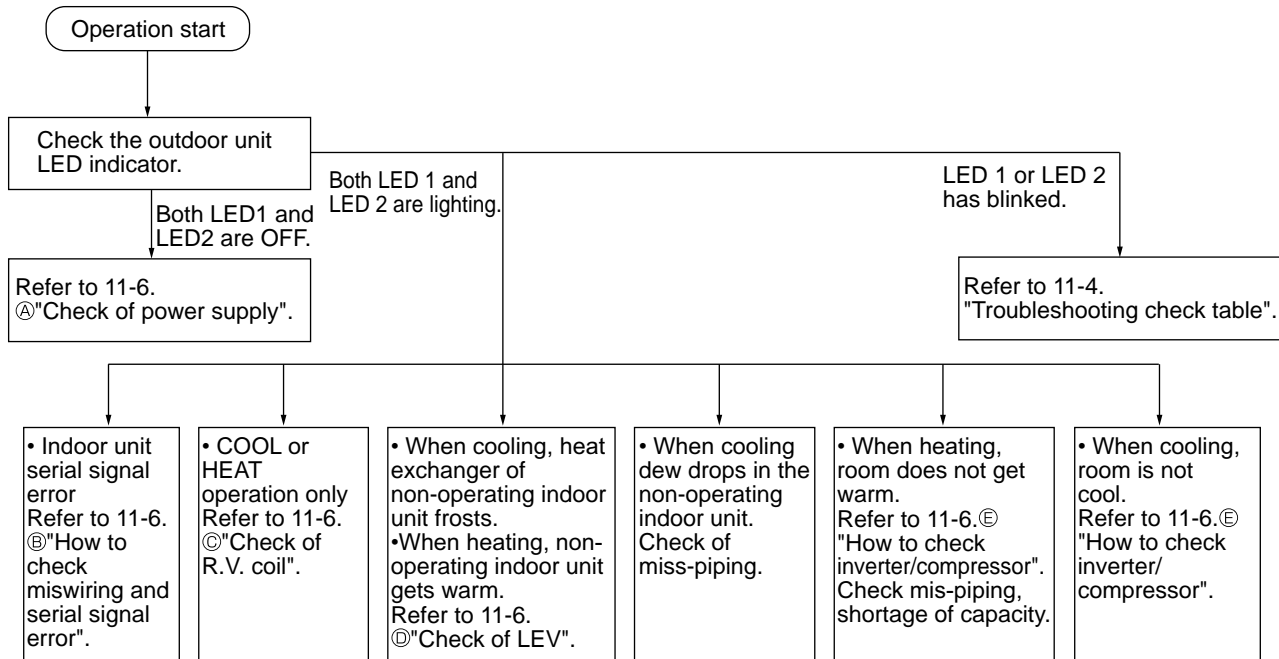

11-4. TROUBLESHOOTING CHECK TABLE

No.	Symptom	Indication		Abnormal point / Condition	Condition	Remedy	
		LED1(Red)	LED2(Yellow)				
1	Outdoor unit does not operate.	Lighted	Once	LEV and drain pump	The indoor unit detects an abnormality in the LEV and drain pump.	<ul style="list-style-type: none"> Refer to 11-6. ⑥ "Check of LEV". Check the drain pump of the indoor unit. 	
2		Lighted	Twice	Outdoor power system	Overcurrent protection cut-out operates 3 consecutive times within 1 minute after the compressor gets started, or converter protection cut-out or bus-bar voltage protection cut-out operates 3 consecutive times within 3 minutes after start-up.	<ul style="list-style-type: none"> Check the connection of the compressor connecting wire. Refer to 11-6. ⑥ "How to check inverter/compressor". Check the stop valve. 	
3		Lighted	3 times	Discharge temperature thermistor	A short circuit is detected in the thermistor during operation, or an open circuit is detected in the thermistor after 10 minutes of compressor start-up.	<ul style="list-style-type: none"> Refer to 11-6. ⑥ "Check of outdoor thermistors". 	
4		Lighted	4 times	Fin temperature thermistor P. C. board temperature thermistor	A short or open circuit is detected in the thermistor during operation.	<ul style="list-style-type: none"> Refer to 11-6. ⑥ "Check of outdoor thermistors". Replace the outdoor control P.C. board. 	
5		Lighted	5 times	Ambient temperature thermistor Outdoor heat exchanger temperature thermistor Defrost thermistor	A short or open circuit is detected in the thermistor during operation. A short circuit is detected in the thermistor during operation, or an open circuit is detected in the thermistor after 5 minutes (in cooling) and 10 minutes (in heating) of compressor start-up. A short circuit is detected in the thermistor during operation, or an open circuit is detected in the thermistor after 5 minutes of compressor start-up.	<ul style="list-style-type: none"> Refer to 11-6. ⑥ "Check of outdoor thermistors". 	
6		Lighted	7 times	Outdoor control system	The nonvolatile memory data cannot be read properly.	<ul style="list-style-type: none"> Replace the outdoor control P.C. board. 	
7		Lighted	8 times	Current sensor	Current sensor protection cut-out operates 2 consecutive times.	<ul style="list-style-type: none"> Replace the outdoor power P.C. board. 	
8		Lighted	11 times	Communication error between P.C. boards M-NET communication error	The communication protection cut-out between boards operates 2 consecutive times. M-NET adapter P.C. board detects an abnormality in the communication error.	<ul style="list-style-type: none"> Check the connecting wire between outdoor control P.C. board and outdoor power P.C. board. Check the connecting wire between M-NET adapter P.C. board and outdoor control P.C. board, or terminal bed. 	
9		Lighted	12 times	Zero cross detecting circuit	The protection cut-out of the zero cross detecting circuit operates 10 consecutive times.	<ul style="list-style-type: none"> Check the connecting wire among outdoor control P.C. board and outdoor power P.C. board. 	
10		Lighted	13 times	Current sensor	A short or open circuit is detected in the input current detection circuit during operation.	<ul style="list-style-type: none"> Replace the outdoor power P.C. board. 	
11		Lighted	14 times	Voltage sensor	A short or open circuit is detected in the input voltage detection circuit during operation.	<ul style="list-style-type: none"> Replace the outdoor power P.C. board. 	
12		Lighted	15 times	Relay operation	No relay operation is detected during operation.	<ul style="list-style-type: none"> Replace the outdoor power P.C. board. 	
13		'Outdoor unit stops and restarts 3 minutes later' is repeated.	Twice	Not lighted	IPM protection	Overcurrent is detected after 30 seconds of compressor start-up.	<ul style="list-style-type: none"> Reconnect compressor connector. Refer to 11-6. ⑥ "How to check inverter/compressor". Check the stop valve. Check the power module (PAM module).
14					Lock protection	Overcurrent is detected within 30 seconds of compressor start-up.	<ul style="list-style-type: none"> Check the stop valve. Check the power module (PAM module).
15			3 times	Not lighted	Discharge temperature protection	The discharge temperature exceeds 240.8 °F during operation. Compressor can restart if discharge temperature thermistor reads 212 °F or less 3 minutes later.	<ul style="list-style-type: none"> Check the amount of gas and refrigerant circuit. Refer to 11-6. ⑥ "Check of LEV".
16			4 times	Not lighted	Fin temperature protection P.C. board temperature protection	The fin temperature exceeds during operation. The P.C. board temperature exceeds during operation.	<ul style="list-style-type: none"> Check refrigerant circuit and refrigerant amount. Refer to 11-6. ⑥ "Check of outdoor fan motor".
17			5 times	Not lighted	High-pressure protection	High-pressure is detected with the high-pressure switch (HPS) during operation. The outdoor heat exchanger temperature exceeds 158 °F during cooling or the indoor gas pipe temperature exceeds 158 °F during heating.	<ul style="list-style-type: none"> Check around of gas and the refrigerant circuit. Check the stop valve.
18			6 times	Not lighted	Pre-heating protection	Overcurrent is detected during pre-heating.	<ul style="list-style-type: none"> Reconnect compressor connector. Refer to 11-6. ⑥ "How to check inverter/compressor". Check the power module.
19			8 times	Not lighted	Converter protection	A failure is detected in the operation of the converter during operation.	<ul style="list-style-type: none"> Replace the outdoor power P.C. board.
20			9 times	Not lighted	Bus-bar voltage protection	The bus-bar voltage exceeds 400 V or falls to low level during compressor operating.	<ul style="list-style-type: none"> Check the voltage of power supply. Replace the outdoor power P.C. board or the outdoor control P.C. board. Refer to 11-6. ⑥ "Check of bus-bar voltage".
20	11 times		Not lighted	Low out side temperature protection(cooling)	The ambient became 10.4°F or less.	—	
				Low out side temperature protection(Heating)	The ambient became 1.4°F or less. (MXZ-3C24NA, MXZ-3C30NA, MXZ-4C36NA, MXZ-5C42NA)		
		Low out side temperature protection(Heating)		The ambient became -18°F or less. (MXZ-2C20NAHZ, MXZ-3C24NAHZ, MXZ-3C30NAHZ)			



No.	Symptom	Indication		Abnormal point / Condition	Condition	Remedy
		LED1(Red)	LED2(Yellow)			
21	'Outdoor unit stops and restarts 3 minutes later' is repeated.	13 times	Not lighted	Outdoor fan motor	A failure occurs 3 consecutive times within 30 seconds after the fan gets started.	• Refer to 11-6. Ⓒ "Check of outdoor fan motor".
22		Lighted	8 times	Current sensor protection	A short or open circuit is detected in the current sensor during compressor operating.	• Replace the outdoor power P.C. board.
23		Lighted	11 times	Communication between P.C. boards protection	Communication error occurs between the outdoor control P.C. board and outdoor power P.C. board for more than 10 seconds.	• Check the connecting wire between outdoor control P.C. board and outdoor power P.C. board.
24		Lighted	12 times	Zero cross detecting circuit protection	Zero cross signal cannot be detected while the compressor is operating.	• Check the connecting wire among outdoor control P.C. board and outdoor power P.C. board.
25	Outdoor unit operates.	Once	Lighted	Primary current protection	The input current exceeds 15 A.	These symptoms do not mean any abnormality of the product, but check the following points. • Check if indoor filters are clogged. • Check if refrigerant is short. • Check if indoor/outdoor unit air circulation is short cycled.
26		Twice	Lighted	High-pressure protection	The indoor gas pipe temperature exceeds 113 °F during heating.	
				Defrosting in cooling	The indoor gas pipe temperature falls 37.4 °F or below during cooling.	
27		3 times	Lighted	Discharge temperature protection	The frequency of the compressor is kept 80 Hz or more and the discharge temperature is kept under 122 °F(COOL mode)/104 °F(HEAT mode) for more than 40 minutes.	• Check refrigerant circuit and refrigerant amount. • Refer to 11-6. Ⓒ "Check of LEV". • Refer to 11-6. Ⓔ "Check of outdoor thermistors".
28		4 times	Lighted	Low discharge temperature protection	The frequency of the compressor is kept 80 Hz or more and the discharge temperature is kept under 102.2 °F for more than 20 minutes.	• Refer to 11-6. Ⓒ "Check of LEV". • Check refrigerant circuit and refrigerant amount.
29	5 times	Lighted	Cooling high-pressure protection	The outdoor heat exchanger temperature exceeds 136.4 °F during operation.	This symptom does not mean any abnormality of the product, but check the following points. • Check if indoor filters are clogged. • Check if refrigerant is short. • Check if indoor/outdoor unit air circulation is short cycled.	
30	Outdoor unit operates normally.	9 times	Lighted	Inverter check mode	The unit is operated with emergency operation switch.	—
31	Operates normally.	Lighted	Lighted	Normal	—	—

NOTE 1. The location of LED is illustrated at the right figure. Refer to 11-7.1.

2. LED is lighted during normal operation.

The flashing frequency shows the number of times the LED blinks after every 2.5-second OFF.

(Example) When the flashing frequency is "2".

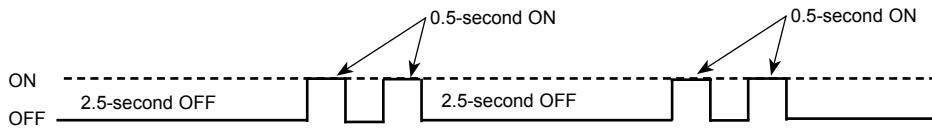

Outdoor control P.C. board (Parts side)

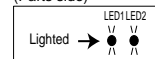

11-5. TROUBLE CRITERION OF MAIN PARTS

**MXZ-3C24NA MXZ-3C30NA MXZ-4C36NA MXZ-5C42NA
MXZ-2C20NAHZ MXZ-3C24NAHZ MXZ-3C30NAHZ**

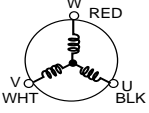
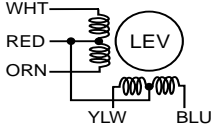
Part name	Check method and criterion								
Defrost thermistor (RT61) Fin temperature thermistor (RT64) Ambient temperature thermistor (RT65) Outdoor heat exchanger temperature thermistor (RT68)	Measure the resistance with a tester. Refer to 11-7. "Test point diagram and voltage", 1. "Outdoor control P.C.board", 2. "Outdoor power P.C. board", for the chart of thermistor.								
Discharge temperature thermistor (RT62)	Measure the resistance with a tester. Before measurement, hold the thermistor with your hands to warm it up. Refer to 11-7. "Test point diagram and voltage", 1. "Outdoor control P.C. board" for the chart of thermistor.								
Compressor 	Measure the resistance between terminals using a tester. (Winding temperature: 14°F ~ 104°F) <table border="1" data-bbox="491 761 1321 853"> <tr> <td>Normal (Each phase)</td> </tr> <tr> <td>MXZ-3C24NA MXZ-3C30NA MXZ-4C36NA</td> </tr> <tr> <td>0.83 Ω ~ 1.03 Ω</td> </tr> </table> Measure the resistance between terminals using a tester. (Winding temperature: 14°F ~ 104°F) <table border="1" data-bbox="491 932 1321 1023"> <tr> <td>Normal (Each phase)</td> </tr> <tr> <td>MXZ-5C42NA MXZ-2C20NAHZ MXZ-3C24NAHZ MXZ-3C30NAHZ</td> </tr> <tr> <td>0.77 Ω ~ 0.95 Ω</td> </tr> </table>	Normal (Each phase)	MXZ-3C24NA MXZ-3C30NA MXZ-4C36NA	0.83 Ω ~ 1.03 Ω	Normal (Each phase)	MXZ-5C42NA MXZ-2C20NAHZ MXZ-3C24NAHZ MXZ-3C30NAHZ	0.77 Ω ~ 0.95 Ω		
Normal (Each phase)									
MXZ-3C24NA MXZ-3C30NA MXZ-4C36NA									
0.83 Ω ~ 1.03 Ω									
Normal (Each phase)									
MXZ-5C42NA MXZ-2C20NAHZ MXZ-3C24NAHZ MXZ-3C30NAHZ									
0.77 Ω ~ 0.95 Ω									
Outdoor fan motor	• Refer to 11-6. ©.								
R.V. coil	Measure the resistance using a tester. (Part temperature: 14°F ~ 104°F) <table border="1" data-bbox="491 1129 1321 1221"> <tr> <td>Normal (Each phase)</td> </tr> <tr> <td>MXZ-3C24NA MXZ-3C30NA MXZ-4C36NA</td> </tr> <tr> <td>1.20 kΩ ~ 1.77 kΩ</td> </tr> </table> Measure the resistance using a tester. (Part temperature: 14°F ~ 104°F) <table border="1" data-bbox="491 1285 1321 1376"> <tr> <td>Normal (Each phase)</td> </tr> <tr> <td>MXZ-5C42NA MXZ-2C20NAHZ MXZ-3C24NAHZ MXZ-3C30NAHZ</td> </tr> <tr> <td>1.24 kΩ ~ 1.86 kΩ</td> </tr> </table>	Normal (Each phase)	MXZ-3C24NA MXZ-3C30NA MXZ-4C36NA	1.20 kΩ ~ 1.77 kΩ	Normal (Each phase)	MXZ-5C42NA MXZ-2C20NAHZ MXZ-3C24NAHZ MXZ-3C30NAHZ	1.24 kΩ ~ 1.86 kΩ		
Normal (Each phase)									
MXZ-3C24NA MXZ-3C30NA MXZ-4C36NA									
1.20 kΩ ~ 1.77 kΩ									
Normal (Each phase)									
MXZ-5C42NA MXZ-2C20NAHZ MXZ-3C24NAHZ MXZ-3C30NAHZ									
1.24 kΩ ~ 1.86 kΩ									
2-way valve solenoid coil MXZ-5C42NA MXZ-2C20NAHZ MXZ-3C24NAHZ MXZ-3C30NAHZ	Measure the resistance using a tester. (Part temperature: 14°F ~ 104°F) <table border="1" data-bbox="491 1421 778 1591"> <tr> <td>Normal</td> </tr> <tr> <td>MXZ-5C42NA MXZ-2C20NAHZ MXZ-3C24NAHZ MXZ-3C30NAHZ</td> </tr> <tr> <td>0.97 kΩ ~ 1.37 kΩ</td> </tr> </table>	Normal	MXZ-5C42NA MXZ-2C20NAHZ MXZ-3C24NAHZ MXZ-3C30NAHZ	0.97 kΩ ~ 1.37 kΩ					
Normal									
MXZ-5C42NA MXZ-2C20NAHZ MXZ-3C24NAHZ MXZ-3C30NAHZ									
0.97 kΩ ~ 1.37 kΩ									
Linear expansion valve 	Measure the resistance using a tester. (Part temperature: 14°F ~ 104°F) <table border="1" data-bbox="491 1630 1074 1774"> <tr> <td>Color of lead wire</td> <td>Normal</td> </tr> <tr> <td>WHT - RED</td> <td rowspan="5">37.4 Ω ~ 53.9 Ω</td> </tr> <tr> <td>RED - ORN</td> </tr> <tr> <td>YLW - RED</td> </tr> <tr> <td>RED - BLU</td> </tr> </table>	Color of lead wire	Normal	WHT - RED	37.4 Ω ~ 53.9 Ω	RED - ORN	YLW - RED	RED - BLU	
Color of lead wire	Normal								
WHT - RED	37.4 Ω ~ 53.9 Ω								
RED - ORN									
YLW - RED									
RED - BLU									
High pressure switch (HPS)		<table border="1" data-bbox="491 1793 1270 1879"> <tr> <td></td> <td>Pressure</td> <td>Normal</td> </tr> <tr> <td rowspan="2">HPS</td> <td>537 ± 22 PSIG</td> <td>Close</td> </tr> <tr> <td>696 ± 15 PSIG</td> <td>Open</td> </tr> </table>		Pressure	Normal	HPS	537 ± 22 PSIG	Close	696 ± 15 PSIG
	Pressure	Normal							
HPS	537 ± 22 PSIG	Close							
	696 ± 15 PSIG	Open							
Defrost heater MXZ-2C20NAHZ MXZ-3C24NAHZ MXZ-3C30NAHZ	Measure the resistance using a tester. (Part temperature: 14°F ~ 104°F) <table border="1" data-bbox="491 1921 778 1985"> <tr> <td>Normal</td> </tr> <tr> <td>0.35 kΩ ~ 0.50 kΩ</td> </tr> </table>	Normal	0.35 kΩ ~ 0.50 kΩ						
Normal									
0.35 kΩ ~ 0.50 kΩ									

11-6. TROUBLESHOOTING FLOW

Outdoor unit does not operate.

Ⓐ Check of power supply

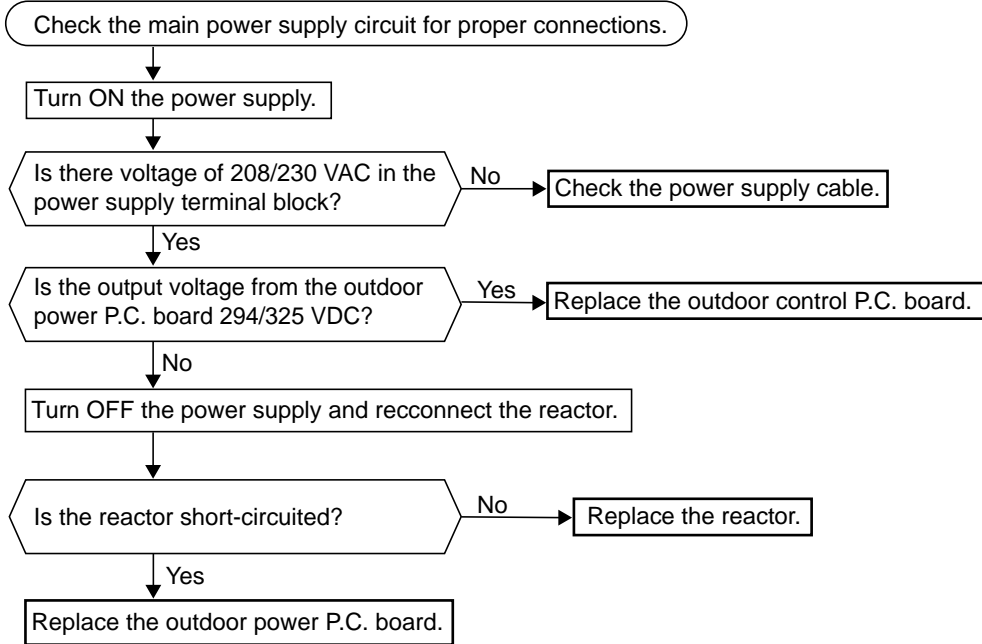

- When unit cannot operate neither by the remote controller nor by EMERGENCY OPERATION switch. Indoor unit does not operate.
- When OPERATION INDICATOR lamp flashes ON and OFF in every 0.5-second. Outdoor unit does not operate.

Ⓑ How to check miswiring and serial signal error (when outdoor unit does not work)

LED indication for communication status

Communication status is indicated by the LED.

Unit status

Blinking: normal communication
Lighting: abnormal communication or not connected

Pattern 1 and 2 is repeatedly displayed alternately. Each pattern is displayed for 15 seconds.

NOTE: "Lighting" in the table below does not indicate abnormal communication.

Outdoor control P.C. board

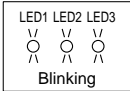

Pattern	LED 1	LED 2	LED 3
1	Unit A status	Unit B status	Lighted
2	Unit C status	Unit D status	Not lighted
3	Unit E status	—	Blinking

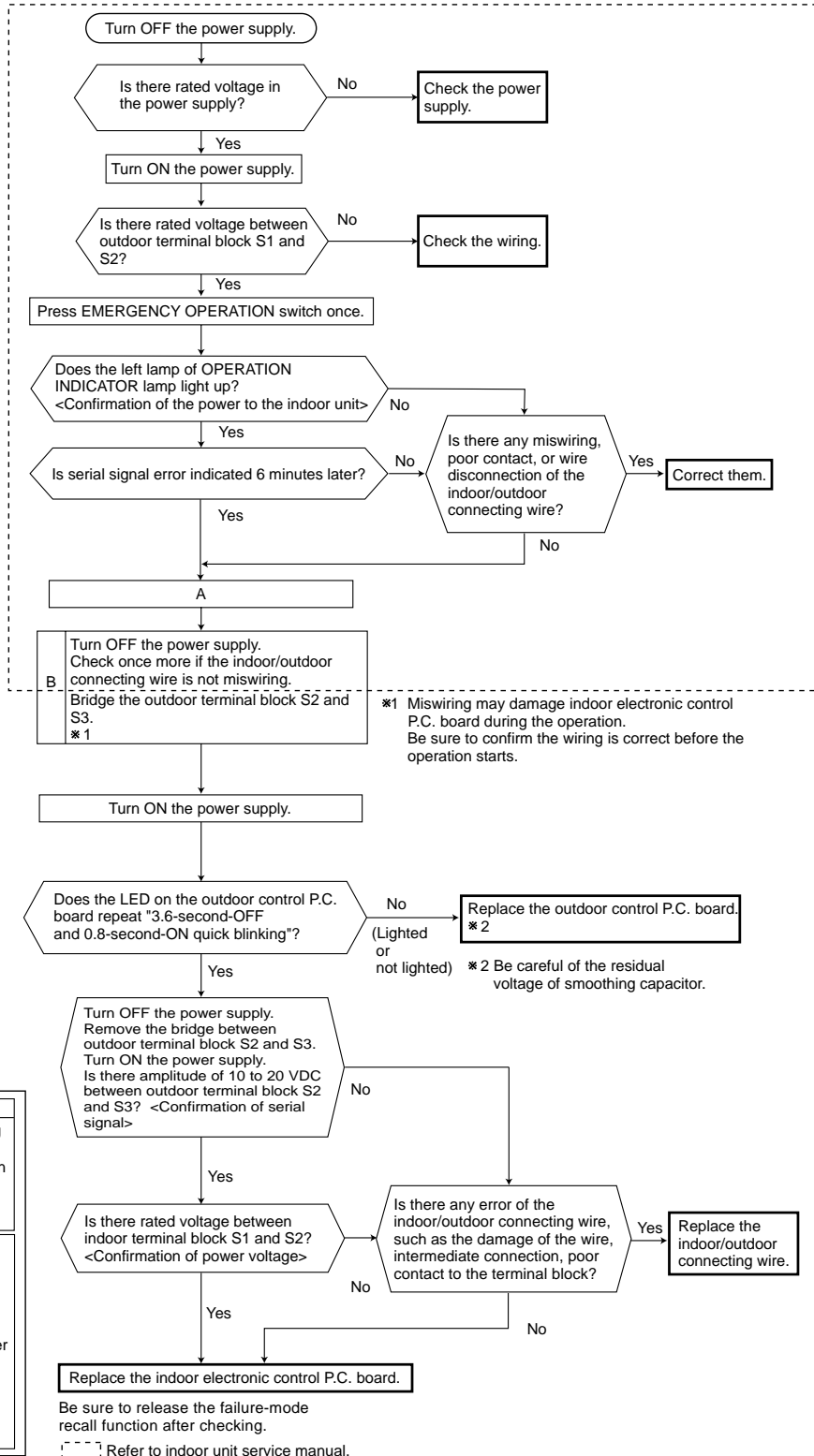

The cooling operation or heating operation does not operate.

© Check of R.V. coil

• When cooling operation does not work.

1. Disconnect the lead wire leading to the compressor.
2. 3 minutes after turning ON the power supply, start EMERGENCY OPERATION in COOL mode.

CNAC CN712	Outdoor control P.C. board
CNAC2	Outdoor power P.C. board

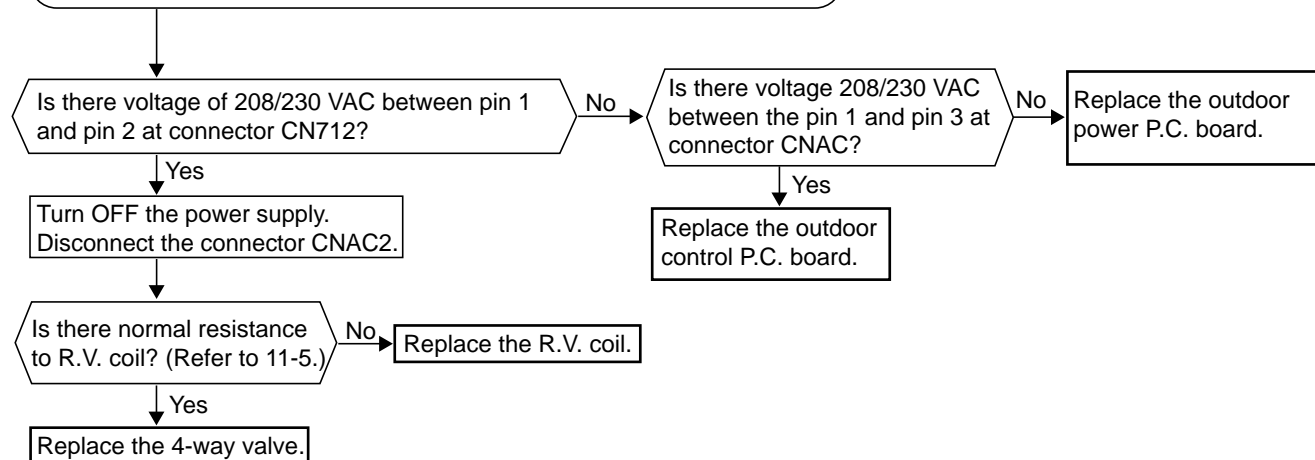

• When heating operation does not work.

1. Disconnect the lead wire leading to the compressor.
2. 3 minutes after turning ON the power supply, start EMERGENCY OPERATION in HEAT mode.

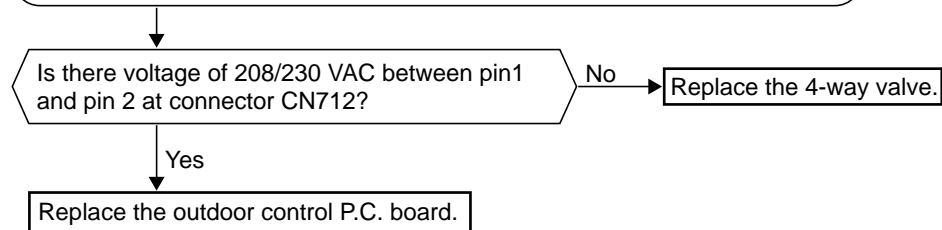

- When cooling, heat exchanger of non-operating indoor unit frosts.
- When heating, non-operating indoor unit gets warm.

④ Check of LEV

Turn ON the power supply to the outdoor unit after checking LEV coil is mounted to the LEV body securely.

Is "click - click" sound heard?
Or, do you feel vibration of LEV coil with your hand?

Yes → Normal

No

Disconnect the connectors.
CN791: LEV A, CN792: LEV B, CN793: LEV C
(MXZ-3C/4C/5C), CN794: LEV D **(MXZ-4C/5C)**,
CN795: LEV E **(MXZ-5C)**
Is there normal resistance to LEV coil?
(Refer to 11-5.)

Yes → Replace the outdoor control P.C. board.

No

Replace LEV coil.

CN791	Outdoor control P.C. board
CN792	
CN793	
CN794	
CN795	

- When heating, room does not get warm.
- When cooling, room does not get cool.

Ⓔ How to check inverter/compressor

Disconnect the terminal of the compressor or the connector (CNMC) between the compressor and the outdoor power P.C. board. 3 minutes after the power supply is turned ON, start EMERGENCY OPERATION.

Measure the voltage between each lead wire leading to the compressor.
 U (BLK) - V (WHT)
 V (WHT) - W (RED)
 W (RED) - U (BLK)
 Output voltage: 50V-250V
 Is proper output voltage detected?
 ※1, ※2

- ※1 • After the outdoor fan starts running, wait for 1 minute or more before measuring the voltage.
- The output voltage values have the tolerance of $\pm 20\%$.
- ※2 • The output differs depending on the capacity or the number of indoor units to be operated.

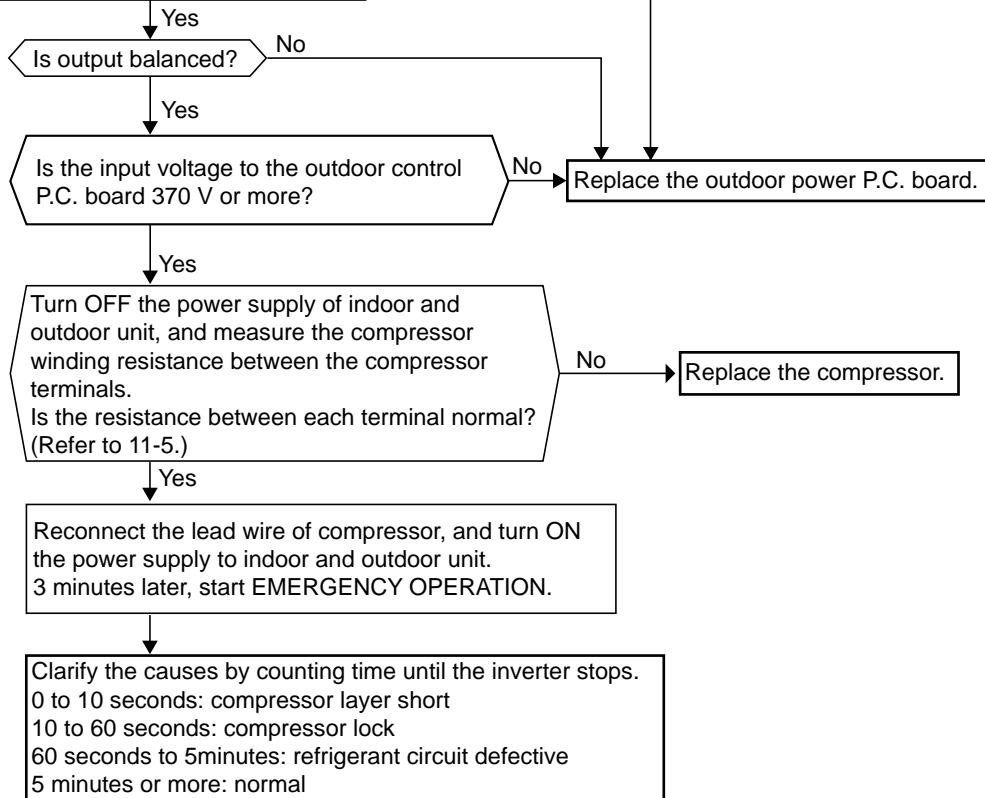

• When thermistor is abnormal.

Ⓔ Check of outdoor thermistors

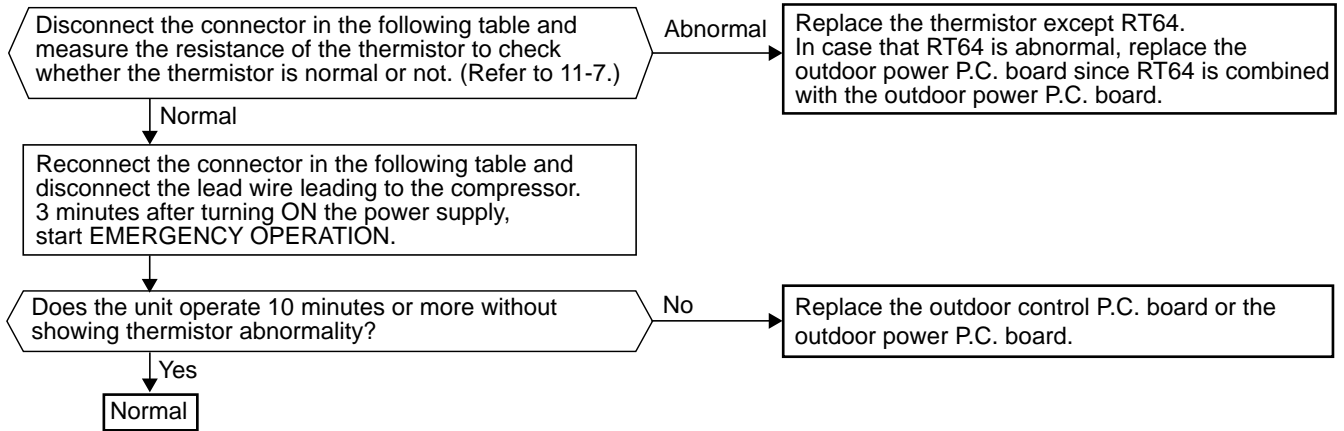

Thermistor	Symbol	Connector, Pin No.	Board
Defrost	RT61	Between CNTH1 pin1 and pin2	Outdoor control P.C. board
Discharge temperature	RT62	Between CNTH1 pin3 and pin4	
Outdoor heat exchanger temperature	RT68	Between CNTH1 pin7 and pin8	
Ambient temperature	RT65	Between CNTH2 pin1 and pin2	Outdoor power P.C. board
Fin temperature	RT64	Between CN171 pin1 and pin2	

• Fan motor does not operate or stops operating shortly after starting the operation.

© Check of outdoor fan motor

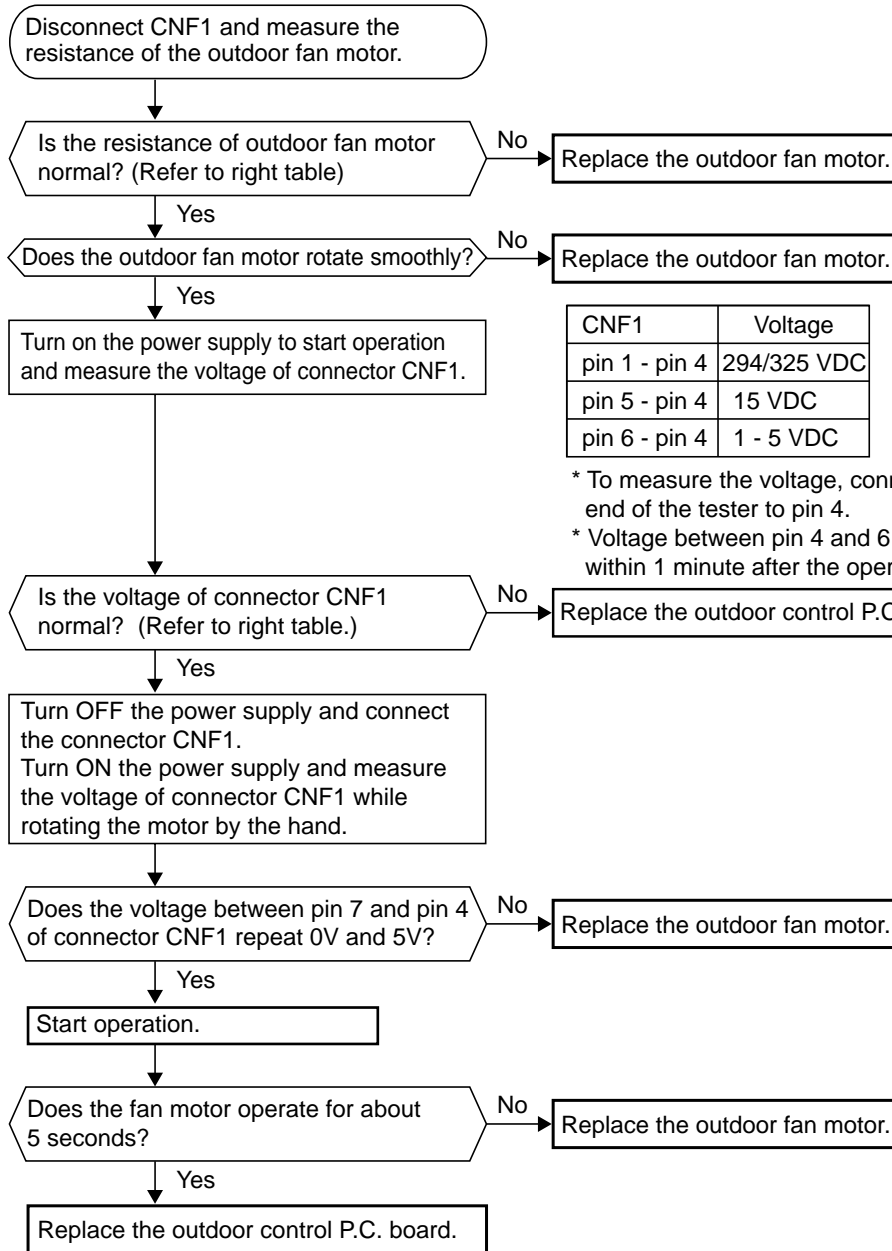

CNF1	Outdoor control P.C. board
------	----------------------------

Measuring points	Resistance
pin 1 - pin 4	∞
pin 5 - pin 4	60 kΩ
pin 6 - pin 4	160 kΩ
pin 7 - pin 4	∞

* To measure the resistance, connect the negative (-) end of the tester to pin 4.

CNF1	Voltage
pin 1 - pin 4	294/325 VDC
pin 5 - pin 4	15 VDC
pin 6 - pin 4	1 - 5 VDC

* To measure the voltage, connect the negative (-) end of the tester to pin 4.

* Voltage between pin 4 and 6 should be measured within 1 minute after the operation starts.

• When the operation frequency does not go up from the lowest frequency.

Ⓜ Check of HPS

CN63H	Outdoor control P.C. board
-------	----------------------------

1. Disconnect the connector CN63H in the outdoor control P.C. board.
2. Check the resistance of HPS after 1 minute has passed since the outdoor unit power supply was turned OFF.

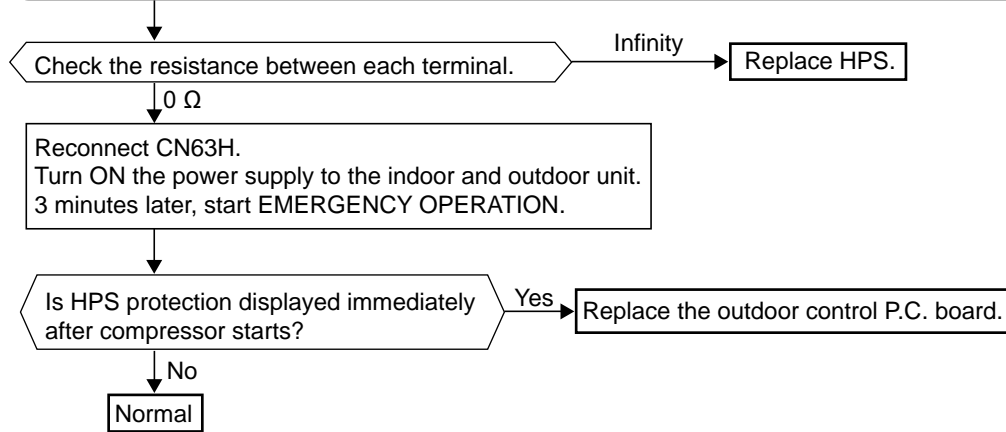

Ⓜ The other cases

Indoor unit does not operate. (different operating models in multi system)

- When you try to run two indoor units simultaneously, one for cooling and the other for heating, the unit which transmits signal to the outdoor units first decides the operation mode.
- When the above situation occurs, set all the indoor units to the same mode, turn OFF the indoor units, and then turn them back ON.
- Though the top of the indoor unit sometimes gets warm, this does not mean malfunction. The reason is that the refrigerant gas continuously flows into the indoor unit even while it is not operating.

Ⓜ Check of bus-bar voltage

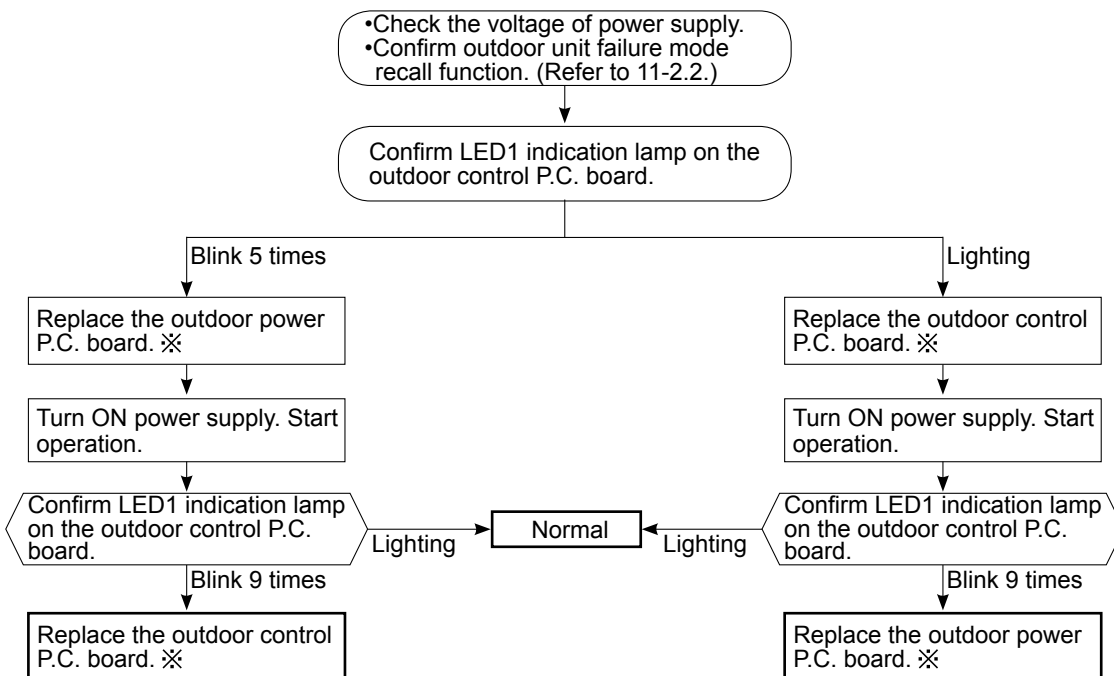

✖ Turn OFF power supply before removing P.C. board.

11-7. TEST POINT DIAGRAM AND VOLTAGE

1. Outdoor control P.C. board

- MXZ-3C24NA MXZ-3C30NA
- MXZ-4C36NA MXZ-5C42NA
- MXZ-2C20NAHZ MXZ-3C24NAHZ
- MXZ-3C30NAHZ

CN741
Signal translation
(To Communication
adaptor board)

CN930
To fan motor

Bus-bur voltage
290 ~ 370 VDC
15 VDC
Rotate instruction
(Constant voltage)
Rotate signal
(Pulse wave)
CNDC
Bus-bur voltage
290 ~ 370
VDC

CN63H
High
pressure
switch

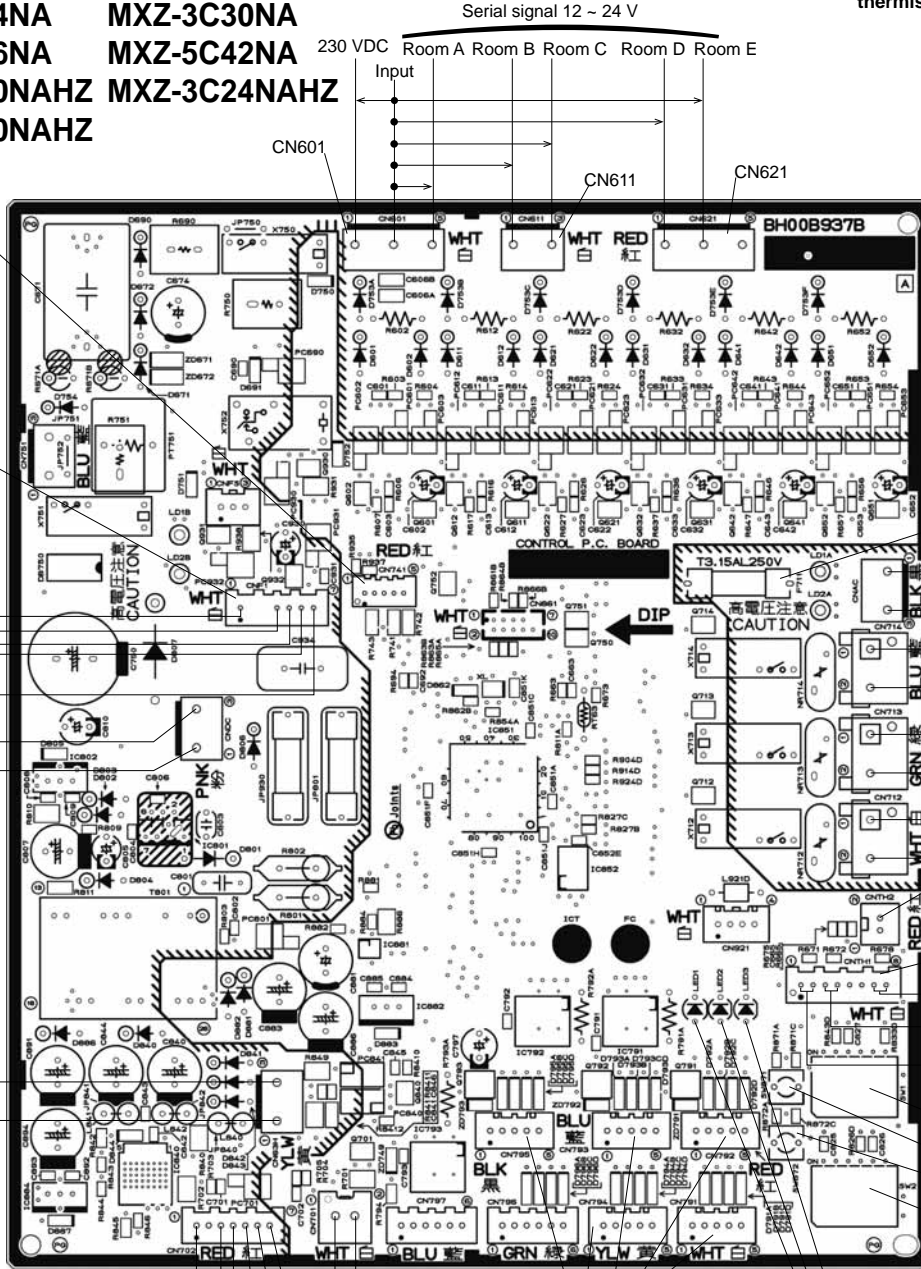

* 15 V-MXZ-3C24/3C30/
4C36NA
18 V-MXZ-5C42NA,
MXZ-2C20/3C24/
3C30NAHZ
CN702 Signal
transmission
(To power board)
5 VDC pulse wave 15

CN701 Signal
transmission
(To power board)
5 VDC pulse wave

CN795 LEV Room E
CN794 LEV Room D
CN793 LEV Room C
CN792 LEV Room B
CN791 LEV Room A
LEV: 12 VDC
pulse wave

Defrost thermistor (RT61)
Ambient temperature thermistor (RT65)
Outdoor heat exchanger temperature
thermistor (RT68)

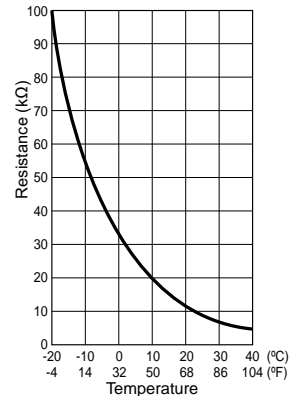

Thermistor R25 = 10 kΩ ± 2%
B constant = 3950 ± 2%
 $R_t = 10 \exp\left\{3950 \left(\frac{1}{273+t} - \frac{1}{298}\right)\right\}$
t : °C = (°F - 32)/1.8

F711 FUSE
T3.15AL 250V

CNAC
to outdoor power P.C.
board 208/230 VAC
Input
CN714 Base heater
208/230 VAC
Input

CN713 Valve coil
208/230 VAC
Input

CN712 R.V. coil
208/230 VAC
Input

CNTH2
Ambient temperature
thermistor
(RT65)

CNTH1
Outdoor heat exchanger
temperature thermistor
(RT68)

Discharge temperature
thermistor (RT62)
Defrost thermistor
(RT61)

SW1

SW871

SW872

SW2

Discharge temperature thermistor (RT62)

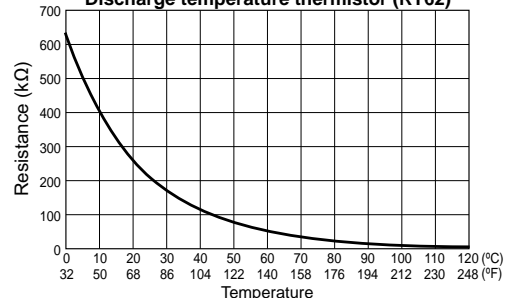

Thermistor R100 = 13.36 kΩ ± 2%
B constant = 4014 ± 2%
 $R_t = 13.36 \exp\left\{4014 \left(\frac{1}{273+t} - \frac{1}{373}\right)\right\}$
t : °C = (°F - 32)/1.8

2. Outdoor power P.C. board

MXZ-3C24NA MXZ-3C30NA MXZ-4C36NA

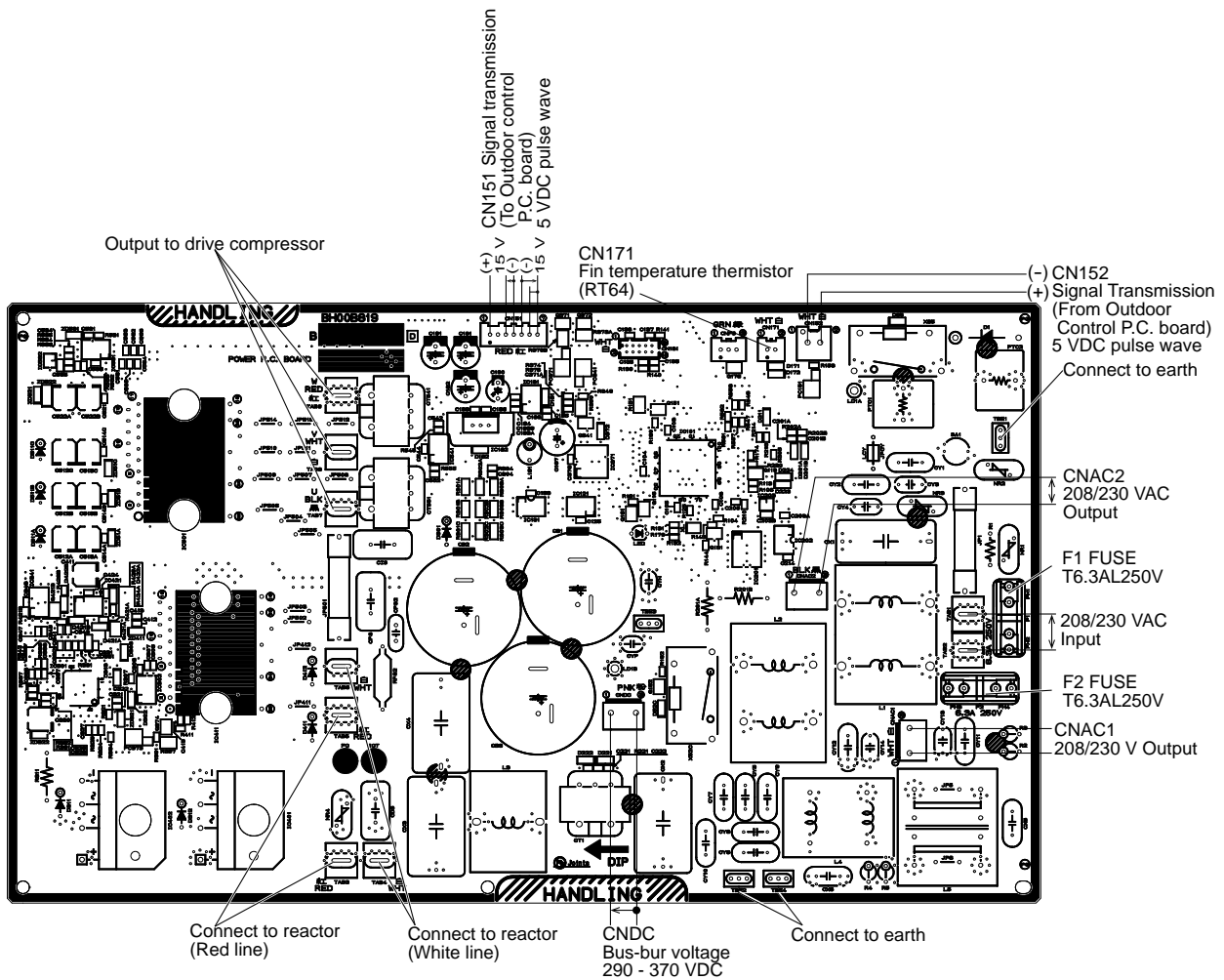

Fin temperature thermistor (RT64)

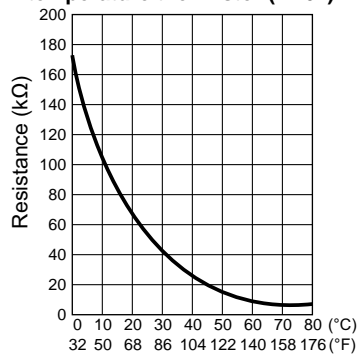

Thermistor $R_{50} = 17 \text{ k}\Omega \pm 2\%$
 B constant = $4150 \pm 3\%$
 $R_t = 17 \exp\left\{4150 \left(\frac{1}{273+t} - \frac{1}{323}\right)\right\}$
 $t : ^\circ\text{C} = (^\circ\text{F} - 32)/1.8$

2. Outdoor power P.C. board

MXZ-5C42NA MXZ-2C20NAHZ MXZ-3C24NAHZ MXZ-3C30NAHZ

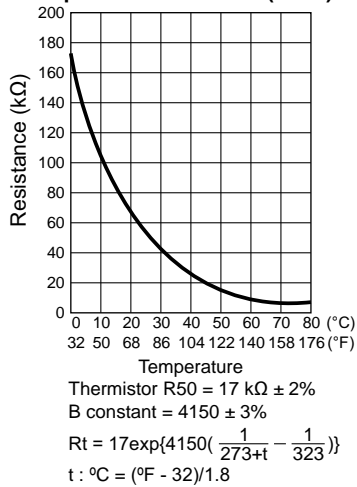
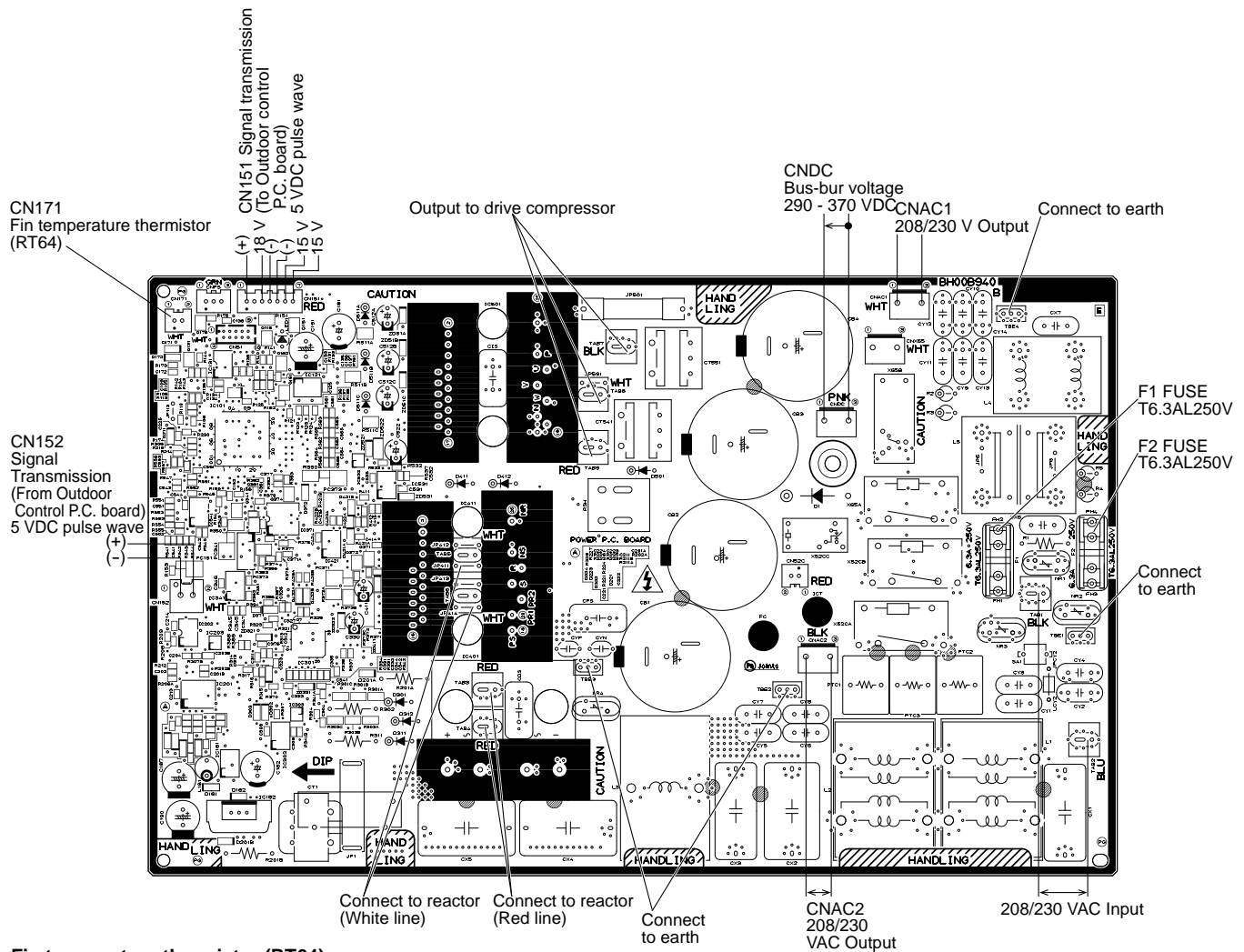

<"Terminal with locking mechanism" Detaching points>

The terminal which has the locking mechanism can be detached as shown below. There are two types (Refer to (1) and (2)) of the terminal with locking mechanism. The terminal without locking mechanism can be detached by pulling it out. Check the shape of the terminal before detaching.

(1) Slide the sleeve and check if there is a locking lever or not.

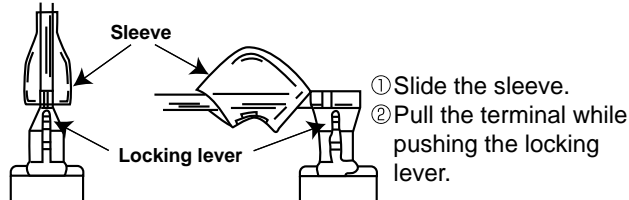

(2) The terminal with this connector has the locking mechanism.

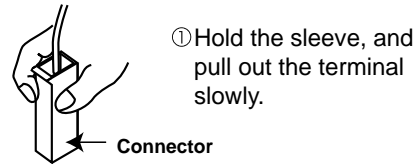

12-1. MXZ-3C24NA MXZ-3C30NA MXZ-4C36NA

Photos : MXZ-4C36NA

NOTE: Turn OFF the power supply before disassembly.

OPERATING PROCEDURE	PHOTOS
<p>1. Removing the panels</p> <ol style="list-style-type: none"> (1) Remove the screws fixing the top panel, and remove the top panel. (2) Remove the screws fixing the service panel. (3) Pull down the service panel, and remove the service panel. (4) Disconnect the power supply and indoor/outdoor connecting wire. (5) Remove the screws fixing the front panel, and remove the front panel. (6) Remove the screws fixing the back panel, and remove the back panel. <p>Photo 3</p>	<p>Photo 1</p> <p>Photo 2</p>

OPERATING PROCEDURE

2. Removing the outdoor control P.C. board, the reactor and the outdoor power P.C. board

- (1) Remove the top panel and the service panel (Refer to 1).
- (2) Disconnect the power supply and indoor/outdoor connecting wire.
- (3) Disconnect the connectors on the outdoor control P.C. board.
- (4) Remove the screws fixing the outdoor control P.C. board holder, and remove the outdoor control P.C. board.
- (5) Disconnect the lead wire from the reactor.
- (6) Remove the screws fixing the reactor, and remove the reactor.
- (7) Disconnect the lead wire of the power P.C. board.
- (8) Disconnect the catches of the PB cover, and remove the PB cover.
- (9) Remove the outdoor power P.C. board.

Photo 6



Screws of the reactor

PHOTOS

Photo 4

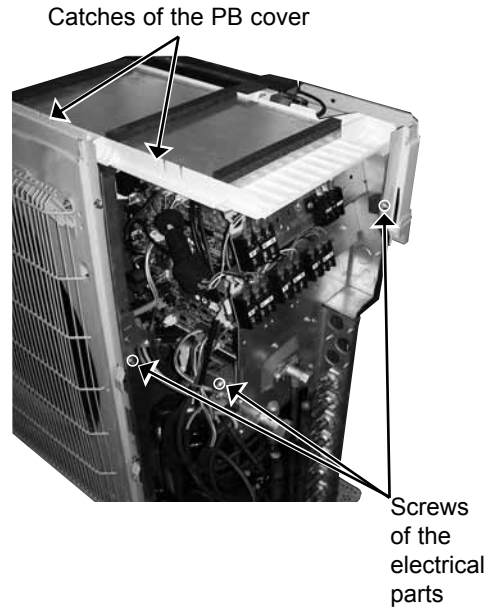
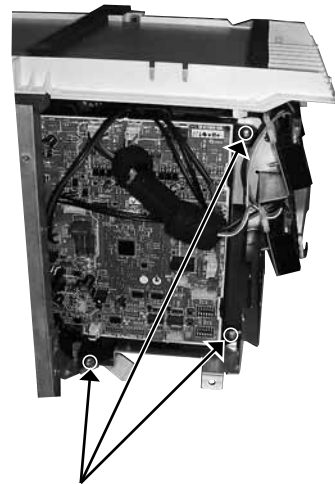

Photo 5



Screws of the outdoor control P.C. board holder

OPERATING PROCEDURE

3. Removing the fan motor

- (1) Remove the top panel, the service panel, and the front panel (Refer to 1).
- (2) Disconnect the power supply and indoor/outdoor connecting wire.
- (3) Disconnect the connector CNF1 on the outdoor control P.C. board.
- (4) Remove the propeller fan.
- (5) Remove the fan motor.

4. Removing the compressor and 4-way valve

- (1) Remove the top panel, the service panel, and the front panel (Refer to 1).
- (2) Disconnect the power supply and indoor/outdoor connecting wire, and remove the back panel.
- (3) Recover gas from the refrigerant circuit.

NOTE: Recover gas from the pipes until the pressure gauge shows 0 kg/cm² (0 MPa).

- (4) Disconnect the compressor lead wire from the terminal of the compressor (U, V, W).
- (5) Disconnect the outdoor control P.C. board connectors: CNF1, CNTH1, CNTH2, CN63H, CN712, CN791, CN792, CN793, CN794 (**MXZ-4C**)
- (6) Remove the screws fixing the electrical parts, and remove the electrical parts (Photo 4).
- (7) Remove the propeller fan.
- (8) Remove the screws fixing the separator, and remove the separator.
- (9) Remove the sound proof felt.
- (10) Detach the brazed parts of the compressor suction and discharge pipes (Photo 9).
- (11) Remove the compressor nuts and remove the compressor (Photo 9).
- (12) Detach the brazed parts of 4-way valve and pipes.

PHOTOS

Photo 7

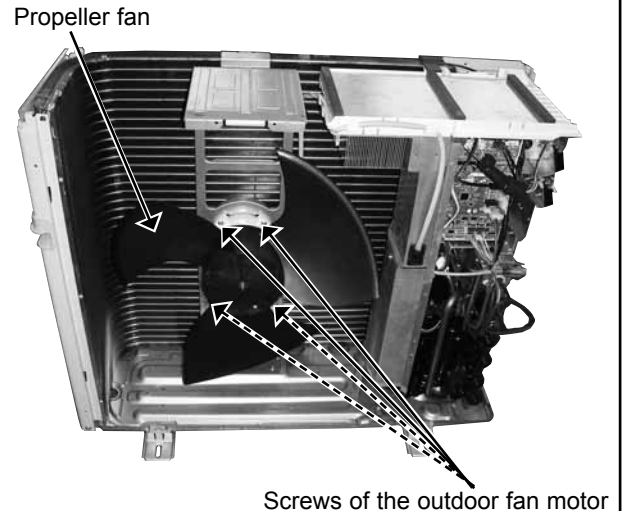
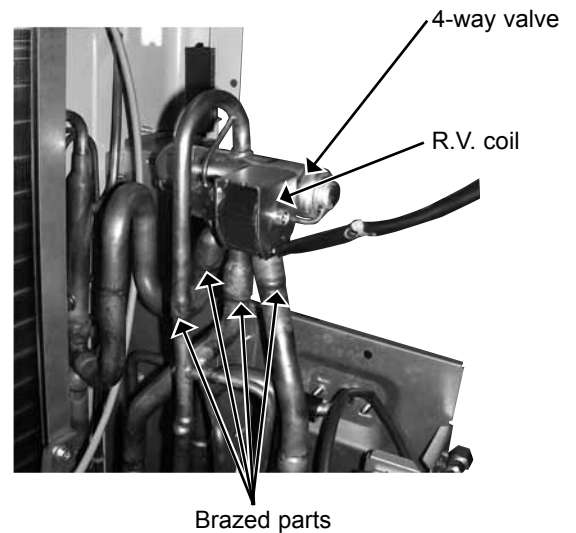

Photo 8



OPERATING PROCEDURE

5. Removing the expansion valve

- (1) Remove the top panel, and the service panel (Refer to 1).
- (2) Disconnect the power supply and indoor/outdoor connecting wire.
(Gas recovery is not required if the unit is pumped down.)
- (3) Remove the LEV coils.
- (4) Detach the brazed parts of the expansion valves and pipes.

PHOTOS

Photo 9

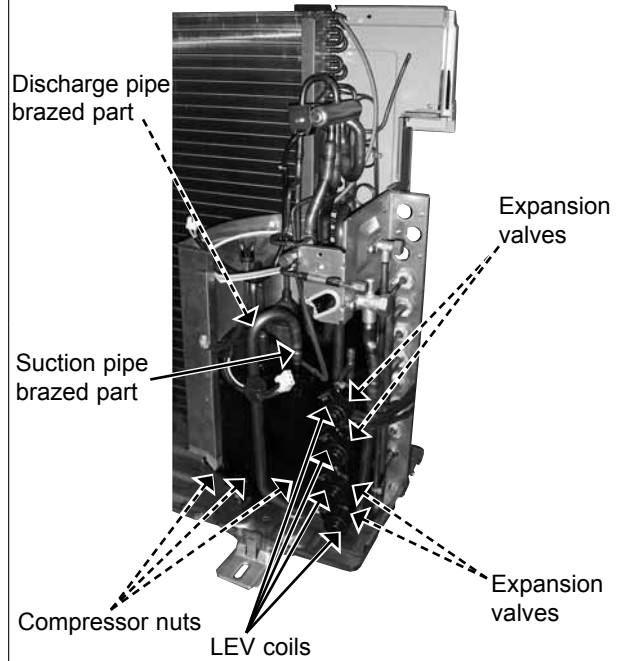

12-2. MXZ-5C42NA MXZ-2C20NAHZ MXZ-3C24NAHZ MXZ-3C30NAHZ

Photos : MXZ-3C30NAHZ

NOTE: Turn OFF the power supply before disassembly.

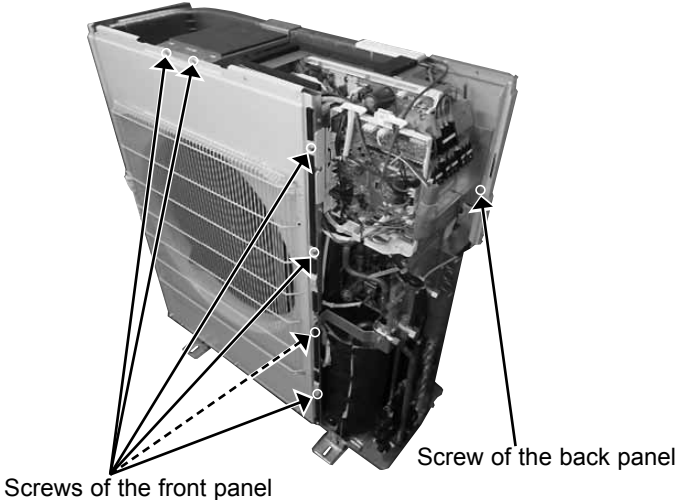
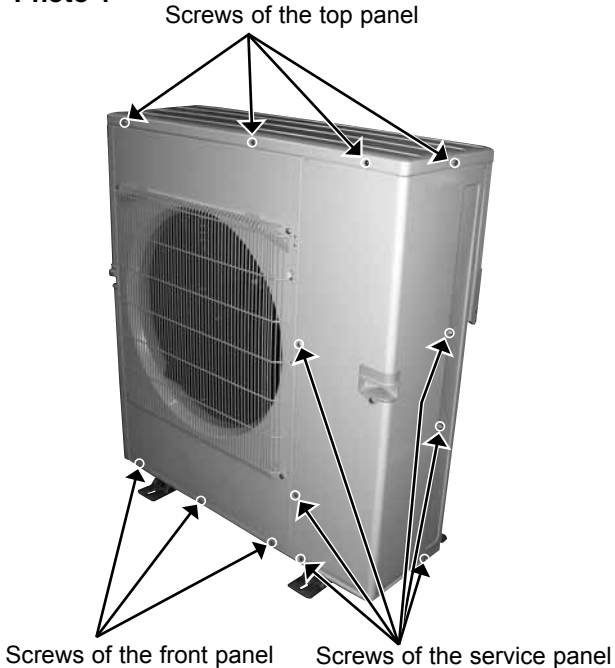
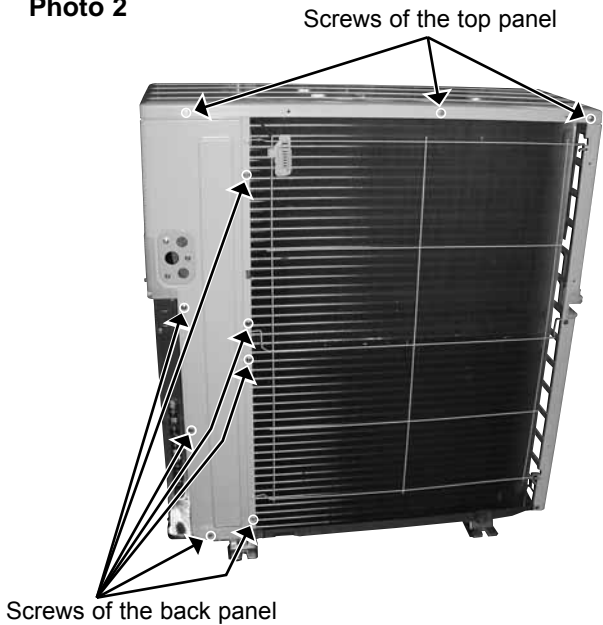
OPERATING PROCEDURE	PHOTOS
<p>1. Removing the panels</p> <ol style="list-style-type: none"> (1) Remove the screws fixing the top panel, and remove the top panel. (2) Remove the screws fixing the service panel. (3) Pull down the service panel, and remove the service panel. (4) Disconnect the power supply and indoor/outdoor connecting wire. (5) Remove the screws fixing the front panel, and remove the front panel. (6) Remove the screws fixing the back panel, and remove the back panel. <p>Photo 3</p>  <p>Screws of the front panel</p> <p>Screw of the back panel</p>	<p>Photo 1</p>  <p>Screws of the top panel</p> <p>Screws of the front panel</p> <p>Screws of the service panel</p> <p>Photo 2</p>  <p>Screws of the top panel</p> <p>Screws of the back panel</p>

OPERATING PROCEDURE

2. Removing the outdoor control P.C. board, the reactor and the outdoor power P.C. board

- (1) Remove the top panel, the service panel and the front panel (Refer to 1).
- (2) Disconnect the power supply and indoor/outdoor connecting wire.
- (3) Disconnect the connectors on the outdoor control P.C. board.
- (4) Remove the screws fixing the outdoor control P.C. board, and remove the outdoor control P.C. board.
- (5) Remove the screws fixing the electrical parts, and remove the electrical parts.
- (6) Remove the screws fixing the TB support, and remove the TB support.
- (7) Remove the screws fixing the control box separator, and remove the control box separator.
- (8) Disconnect the lead wire of the outdoor power P.C. board.
- (9) Remove the screws fixing the outdoor power P.C. board, and remove the outdoor power P.C. board with the outdoor P.C. board holder.
- (10) Remove the screws fixing the control box F, and remove the control box F.
- (11) Remove the screws fixing the reactors, and remove the reactors.

Photo 7



Screws of the control box F

Photo 8

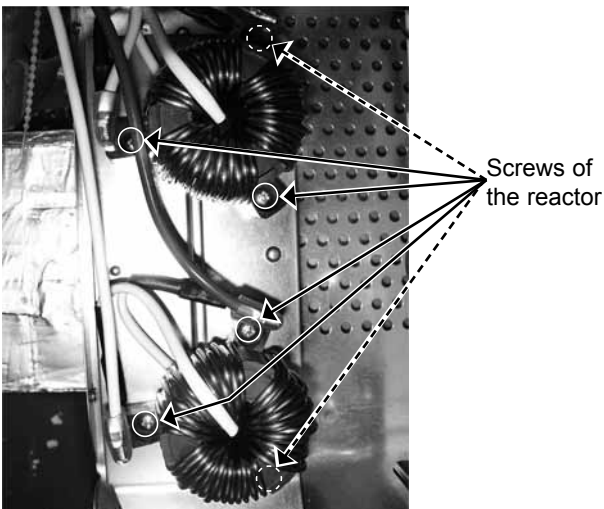

Screws of the reactor

PHOTOS

Photo 4

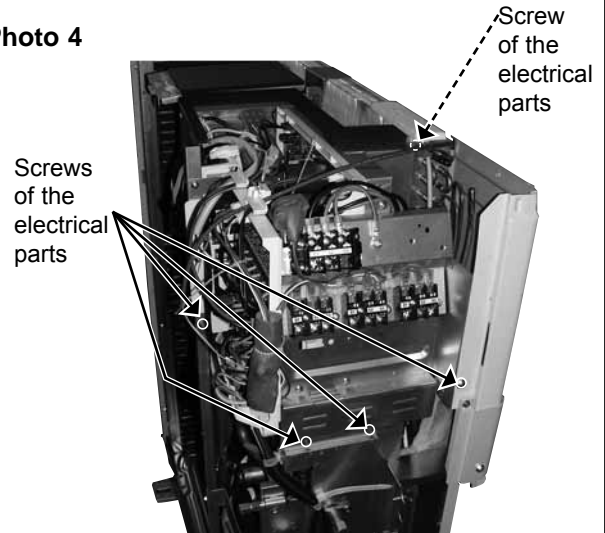

Screws of the electrical parts

Screw of the electrical parts

Photo 5

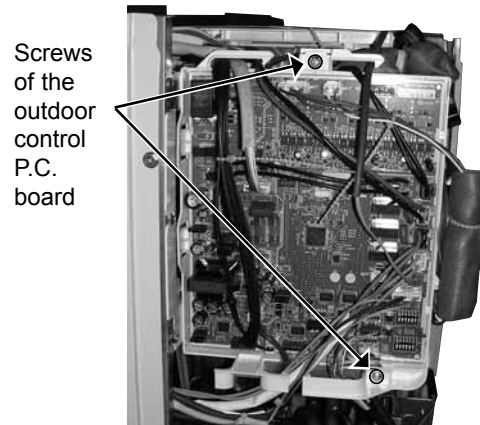

Screws of the outdoor control P.C. board

Photo 6

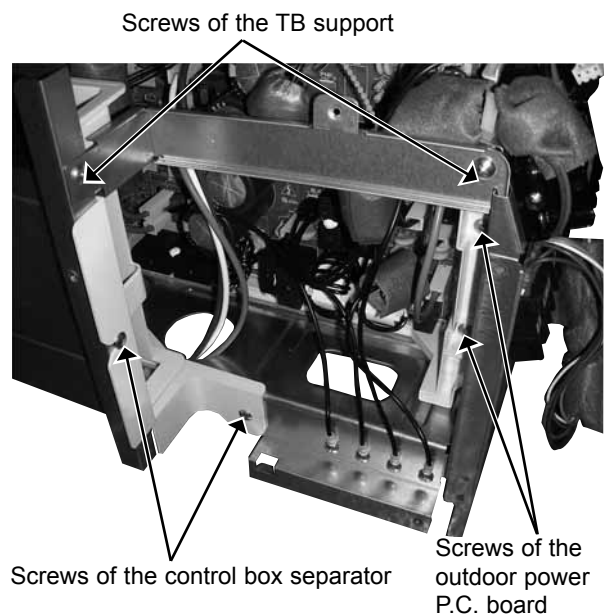

Screws of the TB support

Screws of the control box separator

Screws of the outdoor power P.C. board

OPERATING PROCEDURE

3. Removing the fan motor

- (1) Remove the top panel, the service panel, and the front panel (Refer to 1).
- (2) Disconnect the power supply and indoor/outdoor connecting wire.
- (3) Disconnect the connector CNF1 on the outdoor control P.C. board.
- (4) Remove the propeller fan.
- (5) Remove the fan motor.

4. Removing the compressor and 4-way valve

- (1) Remove the top panel, the service panel and the front panel.
- (2) Disconnect the power supply and indoor/outdoor connecting wire, and remove the back panel.
- (3) Recover gas from the refrigerant circuit.
NOTE: Recover gas from the pipes until the pressure gauge shows 0 kg/cm² (0 MPa).

- (4) Disconnect the compressor lead wire from the terminal of the compressor (U, V, W).
- (5) Disconnect the outdoor control P.C. board connectors: CNF1, CNTH1, CNTH2, CN63H, CN712, CN713, CN714 (**MXZ-C-NAHZ**), CN791, CN792, CN793 (**MXZ-5C42NA**, **MXZ-3C24/30NAHZ**), CN794 (**MXZ-5C42NA**), CN795 (**MXZ-5C42NA**)
- (6) Remove the screws fixing the electrical parts, and remove the electrical parts (Photo 4).
- (7) Remove the propeller fan.
- (8) Remove the screws fixing the VB fixture, and remove the VB fixture.
- (9) Remove the screws fixing the separator, and remove the separator.

NOTE: When installing the separator, insert the tabs of the heat exchanger into the separator.

- (10) Remove the sound proof felt.
- (11) Detach the brazed parts of the suction and discharge pipes (Photo 11).
- (12) Remove the nuts of the compressor, and remove the compressor (Photo 11).
- (13) Detach the brazed parts of 4-way valve and pipes.

PHOTOS

Photo 9

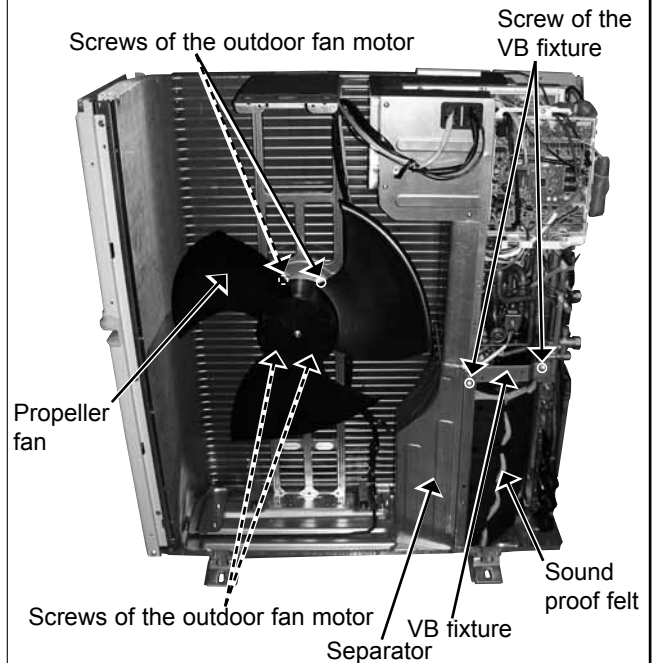
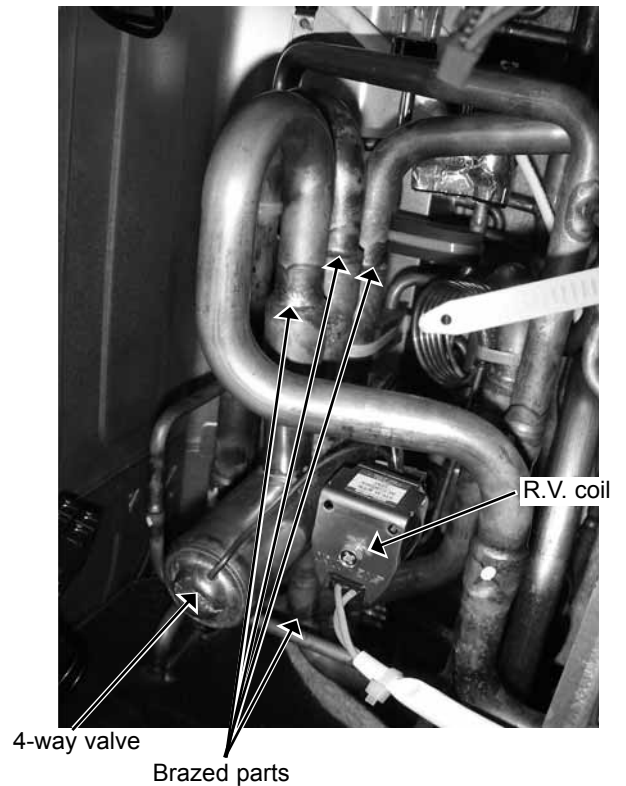

Photo 10



OPERATING PROCEDURE

5. Removing the expansion valve

- (1) Remove the top panel, and the service panel (Refer to 1).
- (2) Disconnect the power supply and indoor/outdoor connecting wire.
(Gas recovery is not required if the unit is pumped down.)
- (3) Remove the LEV coils.
- (4) Detach the brazed parts of expansion valves and pipes.

PHOTOS

Photo 11

Discharge pipe
brazed part

Suction pipe
brazed part

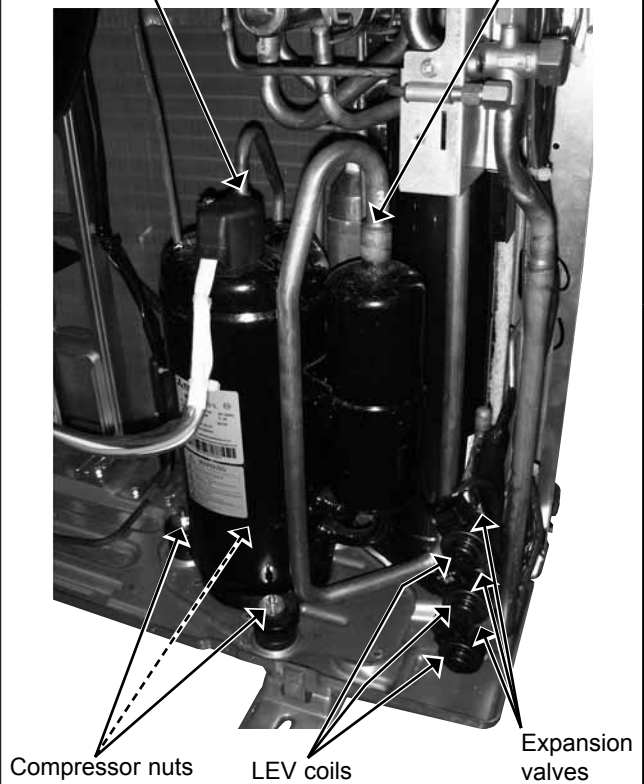

MITSUBISHI ELECTRIC CORPORATION

HEAD OFFICE: TOKYO BLDG., 2-7-3, MARUNOUCHI, CHIYODA-KU, TOKYO 100-8310, JAPAN

© Copyright 2014 MITSUBISHI ELECTRIC CORPORATION
Distributed in Oct. 2014. No. OBH702 REVISED EDITION-A
Distributed in Sep. 2014. No. OBH702
Made in Japan

New publication, effective Oct. 2014
Specifications are subject to change without notice.