

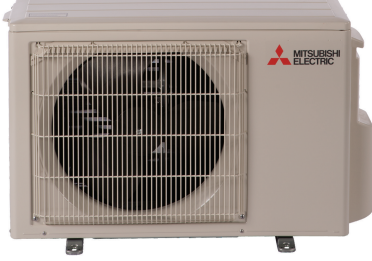

Job Name:

System Reference:

Date:

Indoor Unit: MSZ-WR18NA	Outdoor Unit: <input type="checkbox"/> MUZ-WR18NA-U1 <input type="checkbox"/> MUZ-WR18NA-U2	Wireless Remote Controller
		

GENERAL FEATURES

- Single-zone heat pump systems
- Blue Fin anti-corrosion treatment applied to the outdoor unit heat exchanger for increased coil protection and longer life
- Four fan speeds: Low, Medium, High, Super-high
- Anti-mold filter
- INVERTER-driven heat pump
- Cooling operation range: 32° F to 115° F
- Heating operation range: 5° F to 75° F
- Multiple control options available:
 - Hand-held Remote Controller (provided with unit)
 - kumo cloud® smart device app for remote access
 - Third-party interface options
 - Wired or wireless controllers
- 12-hour timer
- ECONO COOL mode
- AUTO restart
- The outdoor unit powers the indoor unit and should a power outage occur, the system is automatically restarted when the power returns.

SPECIFICATIONS: MSZ-WR18NA & MUZ-WR18NA

Cooling at 95°F ¹	Maximum Capacity	BTU/H	18,000
	Rated Capacity	BTU/H	17,200
	Minimum Capacity	BTU/H	5,800
	Maximum Power Input	W	2,170
	Rated Power Input	W	1,720
	Moisture Removal	Pints/h	2.1
	Sensible Heat Factor		0.86
	Power Factor (208/230V)	%	98/98
Cooling at 82°F	Maximum Capacity	BTU/H	19,872
	Rated Capacity	BTU/H	18,700
	Minimum Capacity	BTU/H	6,404
	Maximum Power Input	W	1,956
	Rated Power Input	W	1,548
Heating at 47°F ²	Maximum Capacity	BTU/H	20,900
	Rated Capacity	BTU/H	18,000
	Minimum Capacity	BTU/H	5,400
	Maximum Power Input	W	2,360
	Rated Power Input	W	1,670
	Power Factor	%	97/97
Heating at 17°F ³	Maximum Capacity	BTU/H	15,000
	Rated Capacity	BTU/H	11,500
	Maximum Power Input	W	2,040
	Rated Power Input	W	1,360
Heating at 5°F ⁴	Maximum Capacity	BTU/H	12,780
	Maximum Power Input	W	1,770
Efficiency	SEER		16.0
	EER ¹		10.0
	HSPF (IV)		8.5
	COP at 47°F ²		3.16
	COP at 17°F in Maximum Capacity ³		2.16
	COP at 5°F in Maximum Capacity ⁴		2.12
Electrical	Voltage, Phase, Frequency		208/230V, 1 phase, 60Hz
	Guaranteed Voltage Range	V AC	187-253
	Voltage: Indoor - Outdoor, S1-S2	V AC	208/230
	Voltage: Indoor - Outdoor, S2-S3	V DC	24
	Short-circuit Current Rating (SCCR)	kA	5
	Recommended Fuse/Breaker Size (Outdoor)	A	15
	Recommended Wire Size (Indoor - Outdoor)	AWG	14
Indoor Unit	MCA	A	1
	Blower Motor Full Load Amperage	A	0.67
	Blower Motor Output	W	30
	Airflow Rate at Cooling, Dry	CFM	625-530-431-328
	Airflow Rate at Cooling, Wet	CFM	562-477-388-295
	Airflow Rate at Heating, Dry	CFM	625-530-431-307
	Sound Pressure Level (Cooling)	dB(A)	47-42-37-30
	Sound Pressure Level (Heating)	dB(A)	47-42-37-30
	Drain Pipe Size	In. (mm)	5/8 (15.88)
	Heat Exchanger Type		Plate fin coil
	External Finish Color		Munsell 1.0Y 9.2/0.2
	Unit Dimensions	W: In. (mm)	36-5/16 (923)

SPECIFICATIONS: MSZ-WR18NA & MUZ-WR18NA

	Package Dimensions	D: In. (mm)	9-13/16 (250)
		H: In. (mm)	12 (305)
		W: In. (mm)	39 (990)
		D: In. (mm)	13 (330)
		H: In. (mm)	15 (380)
	Unit Weight	Lbs. (kg)	28 (13)
	Package Weight	Lbs. (kg)	33 (15)
Indoor Unit Operating Temperature Range	Cooling Intake Air Temp (Maximum / Minimum)*	°F	90F D.B / 73F W.B // 67F D.B / 57F W.B
	Heating Intake Air Temp (Maximum / Minimum)	°F	80F D.B // 70F D.B
Outdoor Unit	MCA	A	10
	MOCP	A	15
	Fan Motor Full Load Amperage	A	0.5
	Fan Motor Output	W	55
	Airflow Rate	CFM	1,243 / 1,229
	Refrigerant Control		LEV
	Defrost Method		Reverse cycle
	Heat Exchanger Type		Plate fin coil
	Blue Fin Coating on Heat Exchanger		Yes
	Sound Pressure Level, Cooling ¹	dB(A)	53
	Sound Pressure Level, Heating ²	dB(A)	51
	Compressor Type		DC INVERTER-driven Twin Rotary
	Compressor Model		SNB130FQBMT
	Compressor Rated Load Amps	A	7.4
	Compressor Locked Rotor Amps	A	9.3
	Compressor Oil Type // Charge	oz.	FV50S // 11.8
	External Finish Color		Ivory Munsell 3Y 7.8/1.1
	Base Pan Heater		Optional
	Unit Dimensions	W: In. (mm)	31-1/2 (800)
		D: In. (mm)	11-1/4 (285)
H: In. (mm)		21-5/8 (550)	
Package Dimensions	W: In. (mm)	38-9/16 (980)	
	D: In. (mm)	16-9/16 (420)	
	H: In. (mm)	39 (990)	
Unit Weight	Lbs. (kg)	81 (37)	
Package Weight	Lbs. (kg)	88 (40)	
Outdoor Unit Operating Temperature Range	Cooling Air Temp (Maximum / Minimum)*	°F	115 / 32
	Cooling Thermal Lock-out / Re-start Temperatures**	°F	-1 / 3
	Heating Air Temp (Maximum / Minimum)	°F	75 / 5
	Heating Thermal Lock-out / Re-start Temperatures**	°F	-9 / -4
Refrigerant	Type		R410A
	Charge	Lbs, oz	2, 10
Piping	Gas Pipe Size O.D. (Flared)	In.(mm)	1/2 (12.7)
	Liquid Pipe Size O.D. (Flared)	In.(mm)	1/4 (6.35)
	Maximum Piping Length	Ft. (m)	65 (20)
	Maximum Height Difference	Ft. (m)	40 (12)
	Maximum Number of Bends		10

SPECIFICATIONS: MSZ-WR18NA & MUZ-WR18NA

Notes

AHRI Rated Conditions (Rated data is determined at a fixed compressor speed)	¹ Cooling (Indoor // Outdoor)	°F	80 DB, 67 WB // 95 DB, 75 WB
	² Heating at 47°F (Indoor // Outdoor)	°F	70 DB, 60 WB // 47 DB, 43 WB
	³ Heating at 17°F (Indoor // Outdoor)	°F	70 DB, 60 WB // 17 DB, 15 WB
Conditions	⁴ Heating at 5°F (Indoor // Outdoor)	°F	70 DB, 60 WB // 5 DB, 4 WB

*Applications should be restricted to comfort cooling only; equipment cooling applications are not recommended for low ambient temperature conditions.
**System cuts out in heating mode to avoid thermistor error and automatically restarts at these temperatures.

ACCESSORIES: MSZ-WR18NA

Anti-allergy Enzyme Filter	□ MAC-408FT-E
Remote Controller Holder	□ U01A01083
kumo touch™ RedLINK™ Wireless Controller	□ MHK2
Deluxe MA Remote Controller ¹	□ PAR-40MAAU
Simple MA Controller ¹	□ PAC-YT53CRAU-J
Touch MA Controller ¹	□ PAR-CT01MAU-SB
Wireless Temperature and Humidity Sensor	□ PAC-USWHS003-TH-1
System Control Interface ²	□ MAC-334IF-E
Wireless Interface 2	□ PAC-USWHS002-WF-2
Thermostat Interface	□ PAC-US444CN-1
kumo station®	□ PAC-WHS01HC-E
USNAP Interface	□ PAC-WHS01UP-E
IT Extender	□ PAC-WHS01IE-E
BACnet® and MODBUS® Interface	□ PAC-UKPRC001-CN-1
Lockdown Bracket for Hand-held Remote Controllers	□ RCMKP1CB
Blue Diamond Sensor Extension Cable — 15 Ft.	□ C13-103
Blue Diamond Alarm Extension Cable — 6.5 Ft.	□ C13-192
Blue Diamond MultiTank — collection tank for use with multiple pumps	□ C21-014
Blue Diamond Rubber Foot Pads	□ F10-010
Mini Condensate Pump — 230 volt application	□ SI30-230
MegaBlue Advanced Blue Diamond Condensate Pump w/ Reservoir & Sensor	□ X87-835 - 110 to 250V
MaxiBlue Advanced Blue Diamond Mini Condensate Pump w/ Reservoir & Sensor (110V) up to 48,000 BTU/H[recommended]	□ X87-711 - 110V
Advanced Blue Diamond Mini Condensate Pump w/ Reservoir & Sensor (208/230V) [recommended]	□ X87-721 - 208/230V
MicroBlue Blue Diamond Mini Condensate Pump (110/208/230V) up to 18,000 BTU/H	□ X85-003
Fascia Kit for MicroBlue Pump – mounts the MicroBlue and sensor directly beneath the indoor unit	□ T18-016
Drain Pan Level Sensor	□ SS610E
(30A/600V/UL) [fits 2" X 4" utility box] - Black	□ TAZ-MS303
(30A/600V/UL) [fits 2" X 4" utility box] - White	□ TAZ-MS303W

¹ Requires MAC-334IF-E

² Allows indoor units to connect to an MA Controller

ACCESSORIES: MUZ-WR18NA

Air Outlet Guide	<input type="checkbox"/> MAC-881SG
Drain Socket	<input type="checkbox"/> MAC-860DS
Optional Defrost Heater	<input type="checkbox"/> MAC-640BH-U
Hail Guard	<input type="checkbox"/> HG-B4
Outdoor Unit 3-1/4 inch Mounting Base (Pair) - Plastic	<input type="checkbox"/> DSD-400P
Condensing Unit Mounting Pad 16" x 36" x 3"	<input type="checkbox"/> ULTRILITE1
Outdoor Unit Stand — 12" High	<input type="checkbox"/> QSMS1201M
Outdoor Unit Stand — 18" High	<input type="checkbox"/> QSMS1801M
Outdoor Unit Stand — 24" High	<input type="checkbox"/> QSMS2401M
Heavy Duty Wall Mounting Bracket— Coated Steel	<input type="checkbox"/> QSWB2000M-1
Heavy Duty Wall Mounting Bracket — 316 Series Stainless Steel	<input type="checkbox"/> QSWBSS
15' x 1/4" x 15' / 1/2" Lineset (Twin-Tube Insulation)	<input type="checkbox"/> MLS141212T-15
30' x 1/4" x 30' / 1/2" Lineset (Twin-Tube Insulation)	<input type="checkbox"/> MLS141212T-30
50' x 1/4" x 50' / 1/2" Lineset (Twin-Tube Insulation)	<input type="checkbox"/> MLS141212T-50
65' x 1/4" x 65' / 1/2" Lineset (Twin-Tube Insulation)	<input type="checkbox"/> MLS141212T-65
100' x 1/4" x 100' / 1/2" Lineset (Twin-Tube Insulation)	<input type="checkbox"/> MLS141212T-100

DIMENSIONS: MSZ-WR18NA

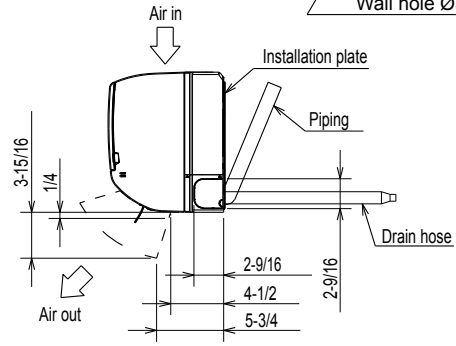
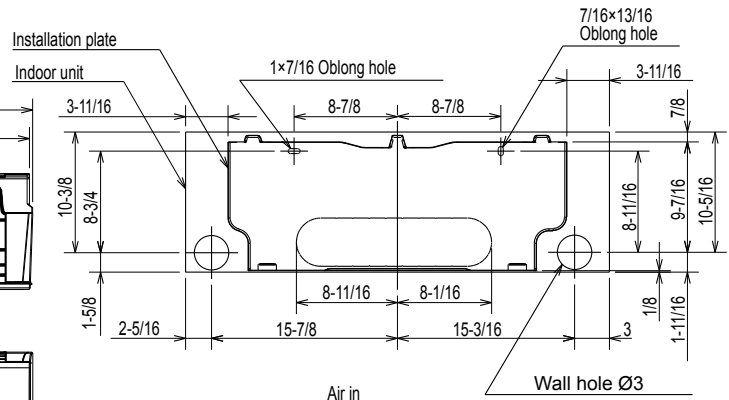
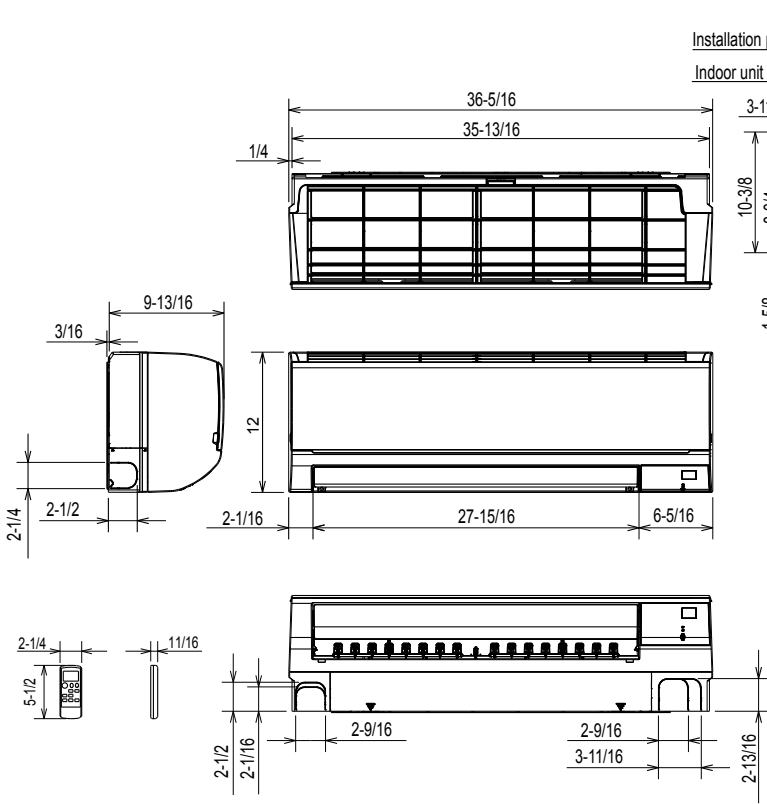

18 KBTU/H

Piping	Insulation	$\varnothing 2$ O.D
	Liquid line	$\varnothing 5/16$ 15-3/8 (Flared connection $\varnothing 1/4$)
	Gas line	$\varnothing 15/32$ 13-3/8 (Flared connection $\varnothing 1/2$)
Drain hose		Insulation $\varnothing 1-1/8$ Connected part $\varnothing 5/8$ O.D

24 KBTU/H

Piping	Insulation	$\varnothing 2$ O.D
	Liquid line	$\varnothing 5/16$ 15-3/8 (Flared connection $\varnothing 3/8$)
	Gas line	$\varnothing 15/32$ 13-3/8 (Flared connection $\varnothing 5/8$)
Drain hose		Insulation $\varnothing 1-1/8$ Connected part $\varnothing 5/8$ O.D

REQUIRED SPACE

*1 4 in. (100 mm) or more when front and sides of the unit are clear

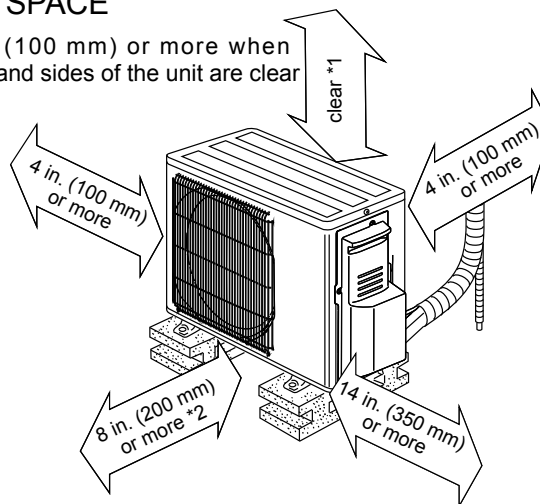

*2 When any 2 sides of left, right and rear of the unit are clear

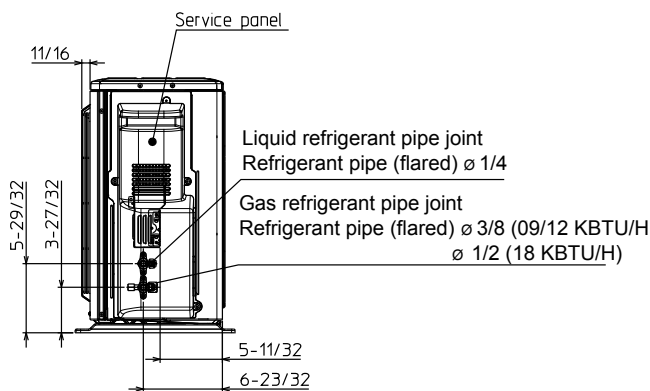
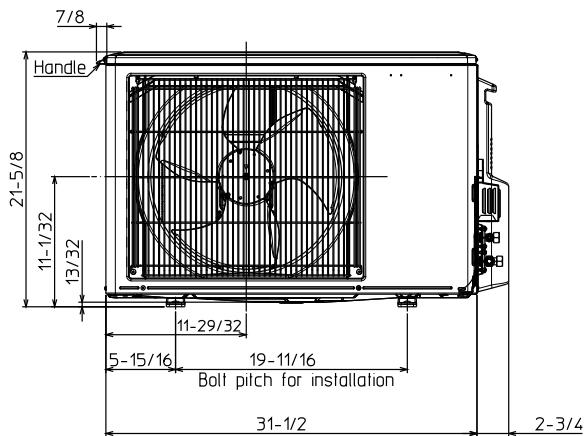
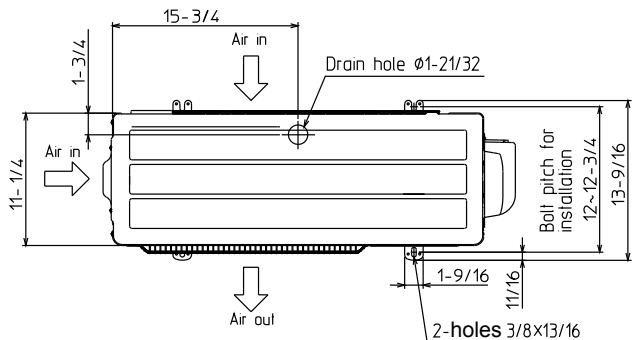

1340 Satellite Boulevard, Suwanee, GA 30024
Toll Free: 800-433-4822 www.mehvac.com