

INSTALLATION INSTRUCTIONS FOR RXGF-CA UPFLOW SIDE MOUNT EXTERNAL FILTER KIT

IMPORTANT

TO ENSURE PROPER INSTALLATION AND OPERATION OF THIS PRODUCT, COMPLETELY READ ALL INSTRUCTIONS PRIOR TO ATTEMPTING TO ASSEMBLE, INSTALL, OPERATE, MAINTAIN OR REPAIR THIS PRODUCT. UPON UNPACKING OF FILTER KIT, INSPECT ALL PARTS FOR DAMAGE PRIOR TO INSTALLATION AND START UP.

1. If there is not an opening in the side of the cabinet one must be cut. It should be cut the full width of the embosses on the unit.
2. Make sure all jacket insulation is removed from the opening.
3. Place the filter frame in position on the side of the furnace jacket. Make sure it is centrally located over the hole. Mark the location of the pre-drilled holes on the filter kit onto the furnace jacket.
4. Using a 1/8" drill bit, drill holes in the furnace jacket where the markings were made in Step 3.
5. Align the holes on the filter frame kit with the holes in the jacket and attach the filter frame with the 3/8" screws provided.
6. Check to ensure the solid bottom base has not been removed.

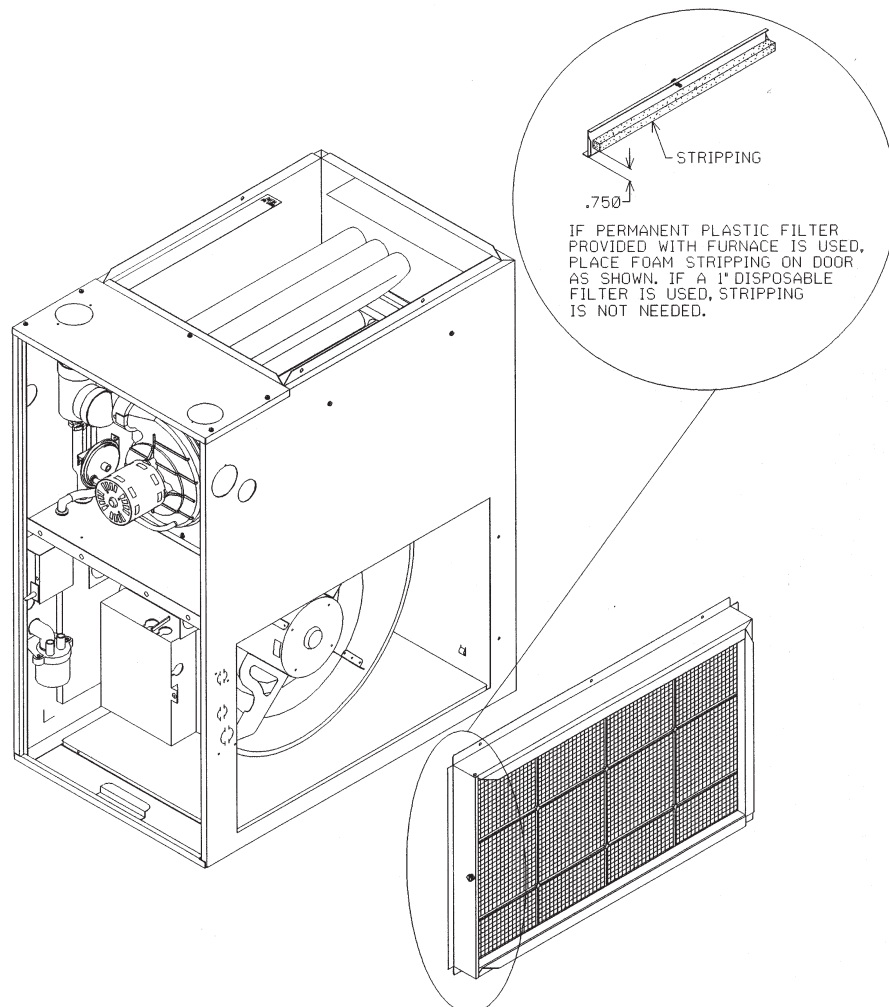

UPFLOW SIDE MOUNT - RXGF-CA

1445A