



## Ruud Air Handler



### **RF1T- Series**

X-13 (ECM) Motor

Efficiencies up to 16 SEER

### **RF1P- Series**

PSC Motor

Efficiencies up to 14.5 SEER



- Front or Bottom Return with aluminum tube and fin coil
- Flow Check Piston for cooling or heat pump operation
- Wall-hanging brackets
- Built in Filter Rack
- AHRI Certified
- UL Certified
- Molex Plug Connections for field installed heater kits
- Dual Voltage Direct Drive Blower with multi-speed motor

- Thermoplastic Drain Pan with bottom primary and secondary connections
- Optional Decorative Grill for front return applications
- Optional Factory Installed Condensate Float Switch which shuts off the outdoor unit in event the condensate pan becomes clogged
- Cabinet air leakage less than 2% at 1 inch H<sub>2</sub>O when tested in accordance with ASHRAE standard 193

# TABLE OF CONTENTS

Engineering Features .....	3
Model Number Identification .....	4
Dimensional Data .....	5-6
Airflow Performance Data .....	7-9
Piston Sizing Chart.....	10
Electrical Data .....	11
Accessories .....	12
Limited Warranty .....	13

## Engineering Features

### RF1T/RF1P- Series

- The most compact unit design available, all standard heat air handler models only 36" [915 mm].
- Rugged wall steel cabinet construction, designed for added strength and versatility.
- 1.0" foil faced insulation for excellent thermal and sound performance.
- Four leg blower motor mount.
- Traditional open wire element design for heat applications.
- Indoor coil design provides low air side pressure drop, high performance and extremely compact size.
- Coils are constructed of aluminum fins and internally grooved aluminum tubing.
- Molded polymer corrosion resistant condensate drain pan is provided for all indoor coils.
- Connection point for high voltage wiring is inside the air handler cabinet. Low voltage connection is made on the outside of the air handler cabinet.
- Concentric knockouts are provided for power connection to cabinet. Installer may pull desired hole size up to 1<sup>3</sup>/<sub>8</sub> inch inches [35 mm] for 7/8 inch [22 mm] conduit.

[ ] Designates Metric Conversions

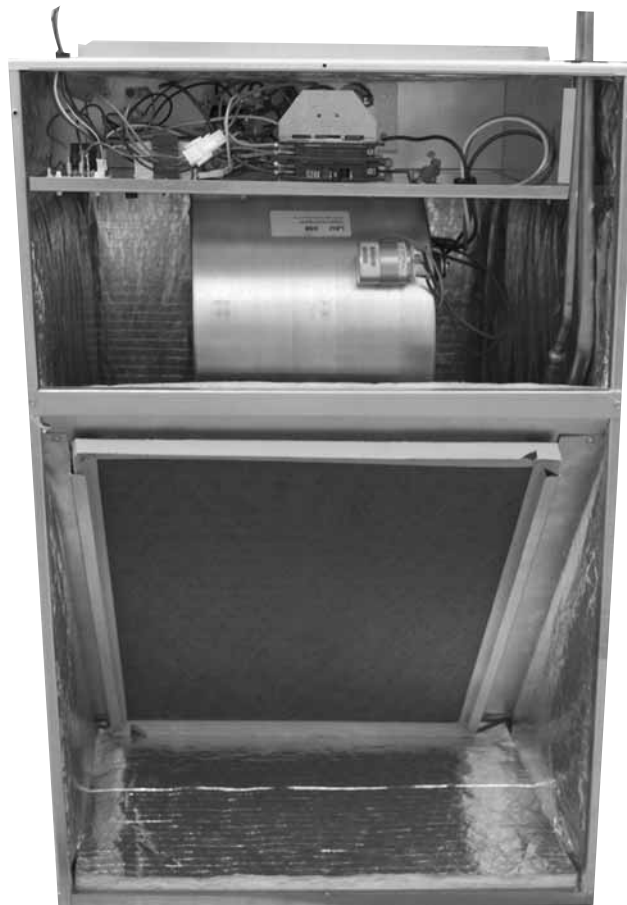

## Model Number Identification

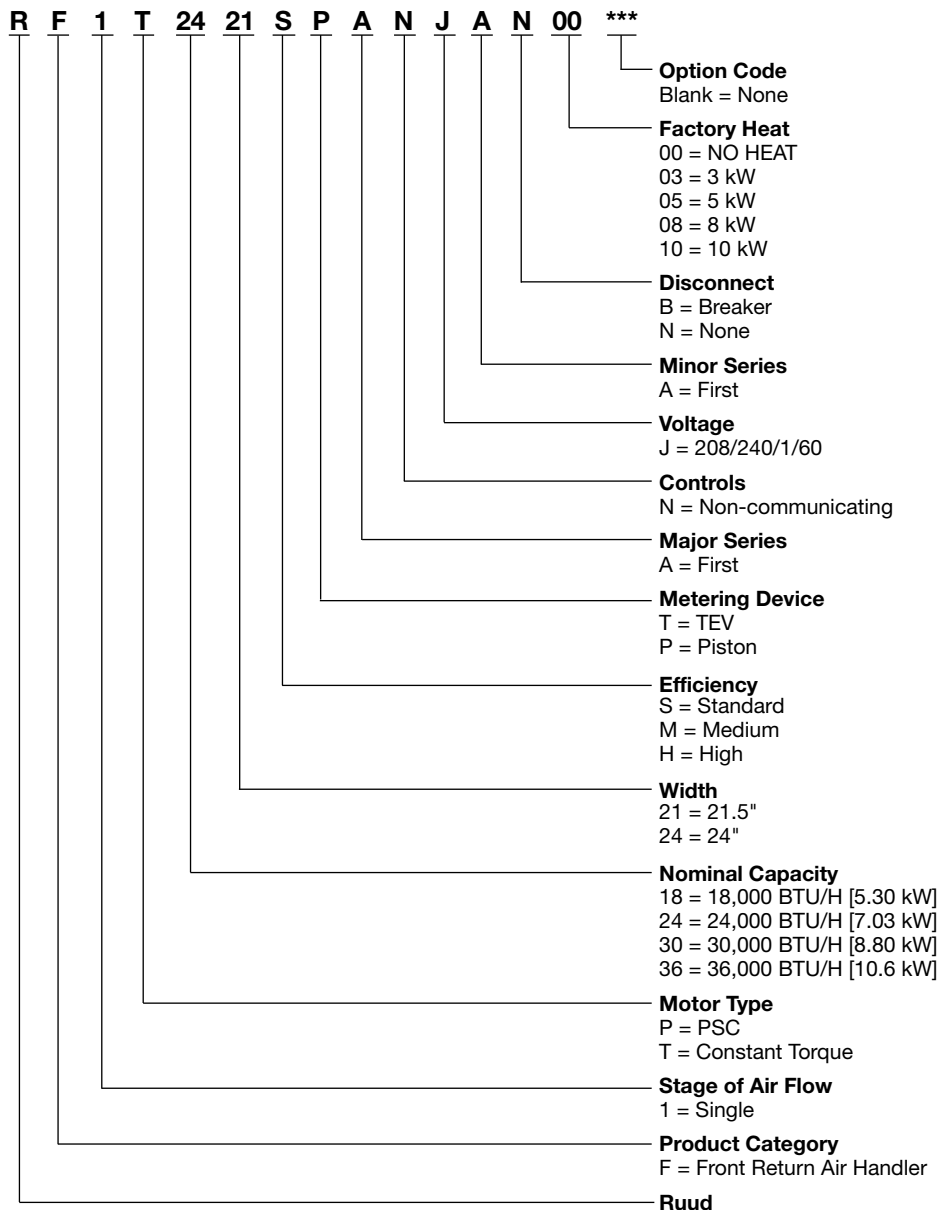

**Note:** All models available with option code 417 (float switch)

- Supply circuit protective devices may be fuses or “HACR” type circuit breakers.
- Largest motor load is included in single circuit.
- If non-standard fuse size is specified, use the next larger fuse size.
- J Voltage (230V) single-phase air handler is designed to be used with single or three phase 230 volt power. In the case of connecting 3-phase power to the air handler terminal block, bring only two leads to the terminal block. Cap, insulate and fully secure the third lead.
- The air handlers are shipped from the factory with the proper indoor coil installed, and cannot be ordered without a coil.

### Available Models

RF1P1821SPANJAB03
RF1P1821SPANJAB05
RF1P1821SPANJAB08
RF1P1821SPANJAN00
RF1P1821STANJAN00
RF1P1821STANJAB03
RF1P1821STANJAB05
RF1P1821STANJAB08
RF1P2421SPANJAB03
RF1P2421SPANJAB05
RF1P2421SPANJAB08
RF1P2421SPANJAB10
RF1P2421SPANJAN00
RF1P2421STANJAN00
RF1P2421STANJAB03
RF1P2421STANJAB05
RF1P2421STANJAB08
RF1P2421STANJAB10
RF1P3024SPANJAB03
RF1P3024SPANJAB05
RF1P3024SPANJAB08
RF1P3024SPANJAB10
RF1P3024SPANJAN00
RF1P3024STANJAN00
RF1P3024STANJAB03
RF1P3024STANJAB05
RF1P3024STANJAB08
RF1P3024STANJAB10
RF1P3624SPANJAB03
RF1P3624SPANJAB05
RF1P3624SPANJAB10
RF1P3624SPANJAN00
RF1P3624STANJAB03
RF1P3624STANJAB05
RF1P3624STANJAB08
RF1P3624STANJAB10
RF1P3624STANJAN00
RF1T2421MTANJAB03
RF1T2421MTANJAB05
RF1T2421MTANJAB08
RF1T2421MTANJAB10
RF1T2421MTANJAN00
RF1T3624MTANJAB03
RF1T3624MTANJAB05
RF1T3624MTANJAB08
RF1T3624MTANJAB10
RF1T3624MTANJAN00

## Unit Dimensions

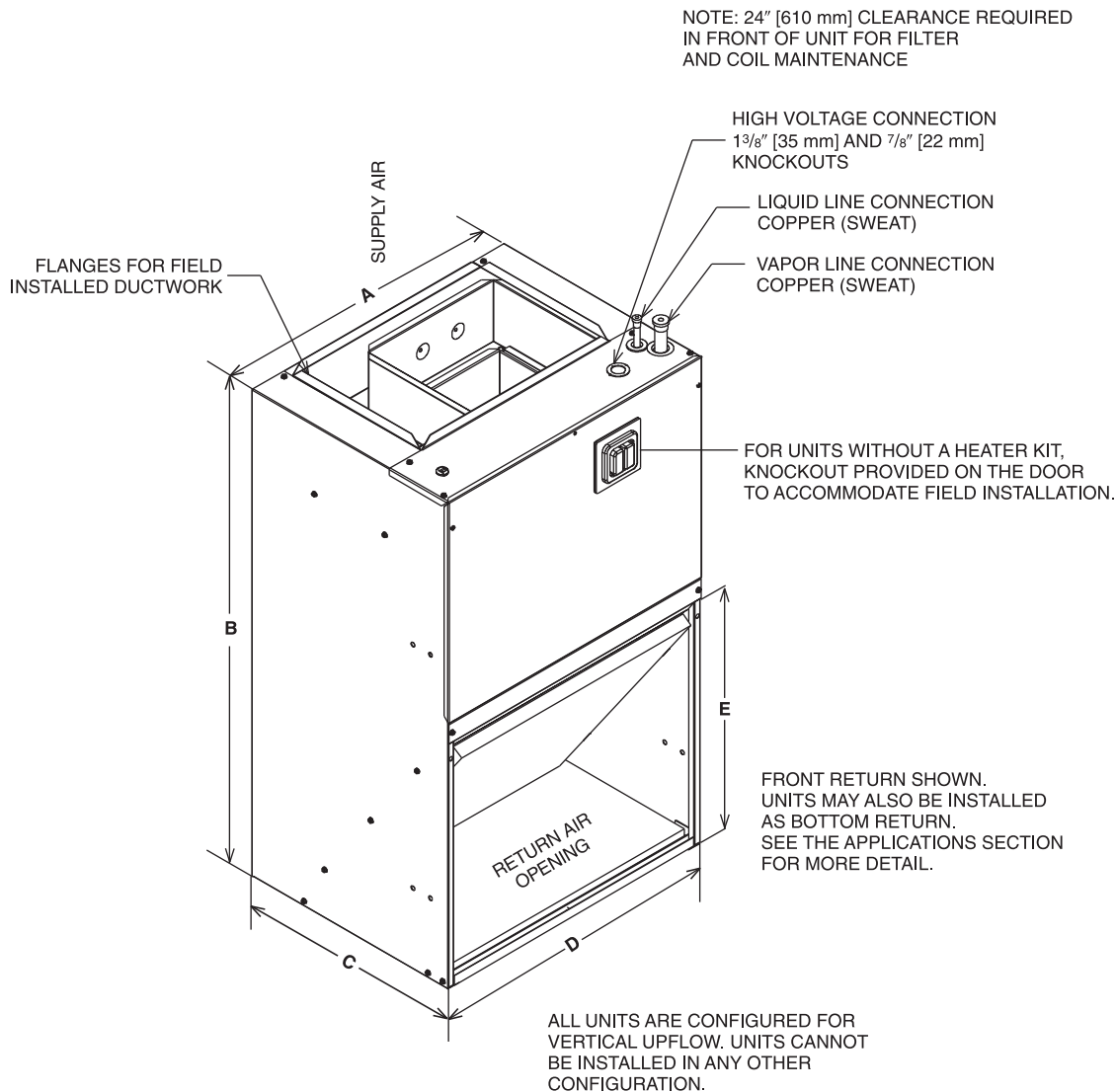

## Unit Dimensions & Weights

Dimensional Data									
Model	(A) Unit Width In. [mm]	(B) Unit Height In. [mm]	(C) Unit Depth In. [mm]	(D) Return Air Opening Width In. [mm]	(E) Return Air Opening Height In. [mm]	Filter Size in. x in. x in. [mm x mm x mm]	Air Flow CFM (Nom.) [L/s]		Unit Weight/ Shipping Weight (Lbs.) [kg]
							Low	High	
RF1P18	21 <sup>1</sup> / <sub>2</sub> [546.1]	36 [914.4]	17 [431.8]	20 [508]	17 <sup>7</sup> / <sub>16</sub> [442.9]	20 X 20 X 1 [508 X 508 X 25.4]	600 [283]	—	80 [36] / 90 [41]
RF1P24	21 <sup>1</sup> / <sub>2</sub> [546.1]	36 [914.4]	17 [431.8]	20 [508]	17 <sup>7</sup> / <sub>16</sub> [442.9]	20 X 20 X 1 [508 X 508 X 25.4]	800 [378]	—	80 [36] / 90 [41]
RF1P30	24 [609.6]	36 [914.4]	21 [533.4]	23 [584.2]	21 <sup>3</sup> / <sub>8</sub> [542.9]	20 X 25 X 1 [508 X 635 X 25.4]	1000 [472]	—	95 [43] x 105 [48]
RF1P36	24 [609.6]	36 [914.4]	21 [533.4]	23 [584.2]	21 <sup>3</sup> / <sub>8</sub> [542.9]	20 X 25 X 1 [508 X 635 X 25.4]	1200 [566]	—	95 [43] x 105 [48]
RF1T24	21 <sup>1</sup> / <sub>2</sub> [546.1]	36 [914.4]	17 [431.8]	20 [508]	17 <sup>7</sup> / <sub>16</sub> [442.9]	20 X 20 X 1 [508 X 508 X 25.4]	600 [283]	800 [378]	95 [43] x 105 [48]
RF1T36	24 [609.6]	36 [914.4]	21 [533.4]	23 [584.2]	21 <sup>3</sup> / <sub>8</sub> [542.9]	20 X 25 X 1 [508 X 635 X 25.4]	1000 [472]	1200 [566]	95 [43] x 105 [48]

[ ] Designates Metric Conversions

## Unit Dimensions (con't.)

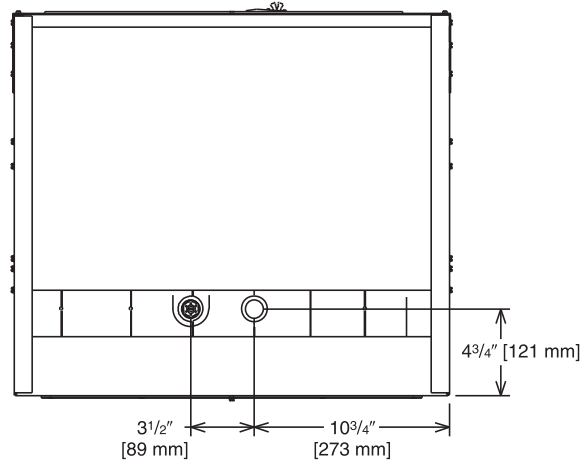
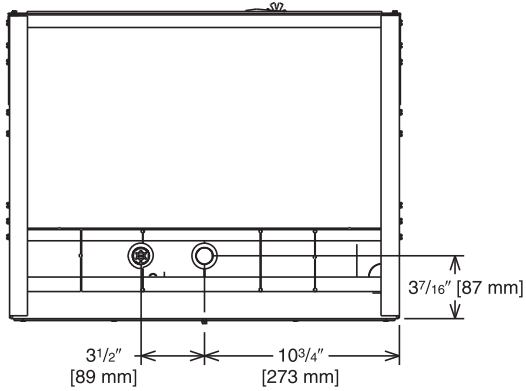
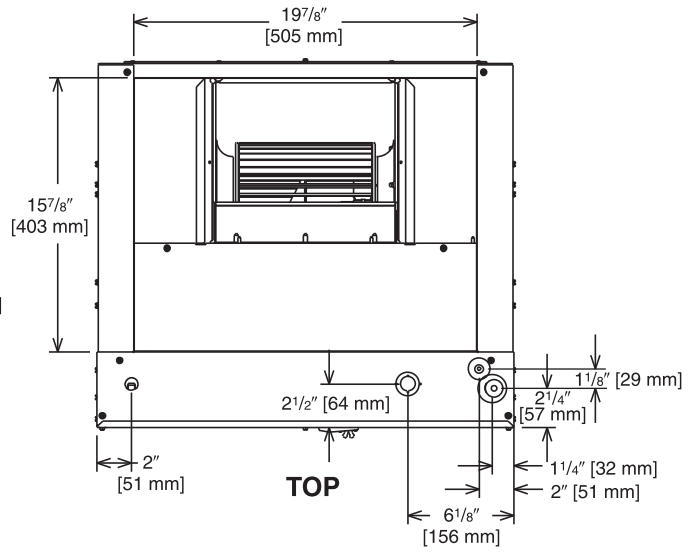
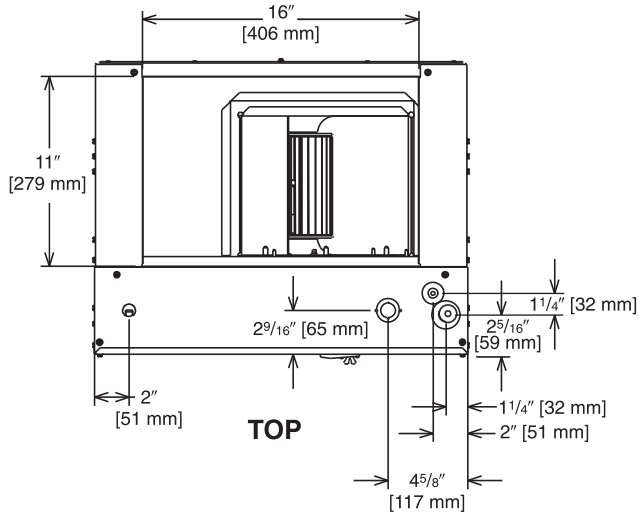

**1 1/2 & 2 TON [5.28 & 7.03 kW] MODELS**

**2 1/2 & 3 TON [8.79 & 10.6 kW] MODELS**

[ ] Designates Metric Conversions

## Airflow Performance

**Airflow performance data is based on cooling performance with a coil and filter in place.** Select performance table for appropriate unit size, voltage and number of electric heaters to be used. Make sure external static applied to unit allows operation within the minimum and maximum limits shown in table

below for both cooling and electric heat operation. For optimum blower performance, operate the unit in the .3 [8 mm] to .7 inches [18 mm] W.C. external static range. Units with coils should be applied with a minimum of .1 inch [3 mm] W.C. external static range.

## Airflow Operating Limits

Cooling BTUH x 1,000 Cooling Tons Nominal	-18 1.5	-24 2	-30 2.5	-36 3
Heat Pump or Air Conditioning Maximum Heat/Cool CFM [L/s] (37.5 CFM [18 L/s]/1,000 BTUH) (450 CFM [212 L/s]/Ton Nominal)	675 [319]	900 [425]	1125 [531]	1350 [637]
Heat Pump or Air Conditioning Nominal Heat/Cool CFM [L/s] (33.3 CFM [16 L/s]/1,000 BTUH) (400 CFM [189 L/s]/Ton Nominal)	600 [283]	800 [378]	1000 [472]	1200 [566]
Heat Pump or Air Conditioning Minimum Heat/Cool CFM [L/s] (30.0 CFM [14 L/s]/1,255 BTUH) (360 CFM [170 L/s]/Ton Nominal)	540 [255]	720 [340]	900 [425]	1080 [510]
Maximum kW Electric Heating & Minimum Electric Heat CFM [L/s]	8 450 [212]	10 690 [326]	10 808 [381]	10 976 [461]
Maximum Electric Heat Rise °F [°C]	54 [12]	44 [7]	44 [7]	44 [7]

[ ] Designates Metric Conversions

## 208V/240V Airflow Performance Data—RF1P (PSC Motor)

Nominal Cooling Capacity Tons [kW]	Manufacturer Recommended Air-Flow Range (Min/Max) CFM	Blower Size/ Motor HP [W] & # of Speeds	Motor Speed from Factory	Motor Speed	PSC							
					CFM Dry Delivery/filter/heaters/RPM/Watts							
					External Static Pressure-Inches W.C. [kPa]							
					0.1 [.02]	0.2 [.05]	0.3 [.07]	0.4 [.10]	0.5 [.12]	0.6 [.15]	0.7 [.17]	
1.5	873/438	10X6 1/5 Hp 2 speed dual voltage	High	High	CFM	873	828	785	751	707	—	—
					RPM	897	923	948	955	981	—	—
					Watts	288	286	283	280	274	—	—
				Low	CFM	572	543	508	477	438	—	—
					RPM	706	753	791	830	869	—	—
					Watts	184	181	187	178	172	—	—
2	1137/764	10X6 1/5 Hp 2 speed dual voltage	High	High	CFM	1137	1097	1034	985	933	868	810
					RPM	1101	1104	1114	1118	1124	1130	1136
					Watts	438	444	446	421	391	377	360
				Low	CFM	867	855	827	798	764	—	—
					RPM	864	902	948	978	1002	—	—
					Watts	324	317	290	285	283	—	—
2.5	1148/802	10X8T 1/4 Hp 2 speed dual voltage	High	High	CFM	1148	1104	1040	980	926	855	750
					RPM	862	889	918	943	962	984	1012
					Watts	411	420	379	367	369	350	317
				Low	CFM	1000	958	910	853	802	—	—
					RPM	788	823	855	889	914	—	—
					Watts	343	344	346	322	317	—	—
3	1363/1048	10X8T 1/3 Hp 2 speed dual voltage	High	High	CFM	1363	1303	1240	1169	1096	1030	—
					RPM	1029	1047	1060	1082	1095	1104	—
					Watts	515	514	468	428	428	394	—
				Low	CFM	1196	1158	1105	1048	—	—	—
					RPM	958	984	1012	1037	—	—	—
					Watts	423	402	402	360	—	—	—

- Notes:
- All 208/240V PSC motors have voltage taps for 208 and 240 volts.
  - All 208/240V PSC motors are shipped on high speed and 240 volts.
  - If the application external static is less than 0.5" WC, adjust the motor speed to the low static speed as described below:
    - Unplug the black motor wire off the relay on the control board and plug in the red motor wire.
    - Replace the cap on the black motor wire.
  - Voltage change (208/240V motors):
    - Move the orange lead to transformer 208V tap from 240V tap. Replace the wire cap on 240V tap.
    - Unplug the purple motor wire off the transformer and plug in the yellow motor wire.
    - Replace the cap on the purple motor wire.
  - The above airflow table lists the airflow information for air handlers with maximum heater allowed for each model.

[ ] Designates Metric Conversions



## 208V/240V Airflow Performance Data—RF1T (X-13 (ECM) Motor)

Nominal Cooling Capacity Tons [kW]	Manufacturer Recommended Air-Flow Range (Min/Max) CFM	Blower Size/ Motor HP [W] & # of Speeds	Motor Speed from Factory	Motor Speed	X-13							
					CFM Dry Delivery/filter/heaters/RPM/Watts							
					External Static Pressure-Inches W.C.							
					0.1 [.02]	0.2 [.05]	0.3 [.07]	0.4 [.10]	0.5 [.12]	0.6 [.15]	0.7 [.17]	
1.5	852/510	10X6 1/3 Hp 2 speed dual voltage	5	3	CFM	852	823	792	770	738	713	690
					RPM	847	881	915	949	989	1026	1057
					Watts	162	151	144	168	182	196	178
			5	2	CFM	669	628	593	552	510	—	—
					RPM	669	713	760	806	852	—	—
					Watts	80	87	82	94	86	—	—
2	973/733	10X6 1/3 Hp 2 speed dual voltage	5	5	CFM	973	945	922	896	872	852	833
					RPM	956	991	1020	1054	1083	1117	1145
					Watts	222	221	247	256	253	261	260
			5	4	CFM	841	807	780	753	733	—	—
					RPM	849	890	925	957	992	—	—
					Watts	160	168	179	187	187	—	—
2.5	1145/894	10X8 1/2 Hp 2 speed dual voltage	5	3	CFM	1145	1122	1084	1064	1055	1025	1002
					RPM	767	780	797	820	855	900	954
					Watts	240	237	239	245	274	276	306
			5	2	CFM	1037	1005	956	924	894	—	—
					RPM	798	845	901	945	980	—	—
					Watts	199	213	196	226	237	—	—
3	1306/1040	10X8 1/2 Hp 2 speed dual voltage	5	5	CFM	1306	1268	1223	1195	1162	1128	1093
					RPM	887	933	986	1019	1056	1096	1133
					Watts	307	313	313	339	373	356	370
			5	4	CFM	1201	1163	1129	1094	1065	1040	—
					RPM	866	914	964	999	1032	—	—
					Watts	278	286	301	324	348	—	—

Notes: X-13 motor speed changes.

All X-13 motors have 5 speed taps. Speed tap 1 is for continuous fan. Speed tap 2 (low static) and speed tap 3 (high static) are for lower tonnage. Speed tap 4 (low static) and speed tap 5 (high static) are for higher tonnage.

X-13 air handlers are always shipped from factory at speed tap 5. To change to 1.5-ton or 2.5-ton airflow, move the blue wire to speed tap 2 or 3 on the X-13 motor. The low static speed tap 2 (lower tonnage) and 4 (higher tonnage) are used for external static below 0.5" WC. The high static speed tap 3 (lower tonnage) and 5 (higher tonnage) are used for external static exceeding 0.5" WC. Move the blue wire to the appropriate speed tap as required by the application needs.

- The airflow for continuous fan (speed tap 1) is 50% of the speed tap 4 airflow.
- The above airflow table lists the airflow information for air handlers with maximum heater allowed for each model.

[ ] Designates Metric Conversions

## Piston Sizing Chart

Indoor Unit	Factory Piston	SEER Rating OD Unit	Nominal Tons	Refrigerant	Orifice Size
RF1P1821SPANJA	0.047	13	1.5	R410a	0.047
		14	1.5	R410a	0.049
		13	1.5	R22	0.049
		12	1.5	R22	0.051
		10	1.5	R22	0.053
RF1P2421SPANJA	0.053	13	2	R410a	0.053
		14	2	R410a	0.057
		13	2	R22	0.057
		12	2	R22	0.061
		10	2	R22	0.063
RF1P3024SPANJA	0.061	13	2.5	R410a	0.061
		14	2.5	R410a	0.063
		13	2.5	R22	0.065
		12	2.5	R22	0.065
		10	2.5	R22	0.065
RF1P3624SPANJA	0.065	13	3	R410a	0.065
		14	3	R410a	0.068
		13	3	R22	0.069
		12	3	R22	0.070
		10	3	R22	0.070

## RF1P/RF1T Electrical Data – Blower Motor Only – No Electric Heat

Model/Nominal Cooling Tons	Voltage	Phase	Hertz	HP [W]	RPM	Speeds	Circuit Amps.	Minimum Circuit Ampacity	Maximum Circuit Protector
RF1P1821	208/230	1	60	1/5 [149]	1075	2	1.5	3	15
RF1P2421	208/230	1	60	1/5 [149]	1075	2	1.5	3	15
RF1P3024	208/230	1	60	1/4 [186]	1075	2	2.5	4	15
RF1P3624	208/230	1	60	1/3 [249]	1075	2	2.5	4	15
RF1T2421	208/230	1	60	1/3 [249]	300-1100	4	1.6	3	15
RF1T3624	208/230	1	60	1/2 [373]	300-1100	4	2.7	4	15

\*Blower motors are all single phase motors.

## RF1P/RF1T Electrical Data – with Electric Heat

Installation of the U.L. Listed original equipment manufacturer provided heater kits listed in the table below is recommended for all auxiliary heating requirements.

Cooling Capacity Tons	Model No.	Heater kW (208/240V)	PH/Hz	No. Elements - kW Per	Type Supply Circuit	Circuit Amps.	Motor Ampacity	Minimum Circuit Ampacity	Maximum Circuit Protection
RF1P/RF1T 18	RXHJ-21B/T03J	2.25/3.0	1/60	1-3.0	Single	10.8/12.5	1.5	16/18	20/20
	RXHJ-21B/T05J	3.6/4.8	1/60	1-4.8	Single	17.3/20.0	1.5	24/27	25/30
	RXHJ-21B/T08J	5.4/7.2	1/60	2-3.6	Single	26.0/30.0	1.5	35/40	35/40
RF1P/RF1T 24	RXHJ-21B/T03J	2.25/3.0	1/60	1-3.0	Single	10.8/12.5	1.5	16/18	20/20
	RXHJ-21B/T05J	3.6/4.8	1/60	1-4.8	Single	17.3/20.0	1.5	24/27	25/30
	RXHJ-21B/T08J	5.4/7.2	1/60	2-3.6	Single	26.0/30.0	1.5	35/40	35/40
	RXHJ-21B/T10J	7.2/9.6	1/60	2-4.8	Single	34.6/40.0	1.5	46/52	50/60
RF1P/RF1T 30	RXHJ-24B/T03J	2.25/3.0	1/60	1-3.0	Single	10.8/12.5	2.5	17/19	20/20
	RXHJ-24B/T05J	3.6/4.8	1/60	1-4.8	Single	17.3/20.0	2.5	25/29	25/30
	RXHJ-24B/T08J	5.4/7.2	1/60	2-3.6	Single	26.0/30.0	2.5	36/41	40/45
	RXHJ-24B/T10J	7.2/9.6	1/60	2-4.8	Single	34.6/40.0	2.5	47/54	50/60
RF1P/RF1T 36	RXHJ-24B/T03J	2.25/3.0	1/60	1-3.0	Single	10.8/12.5	2.5	17/19	20/20
	RXHJ-24B/T05J	3.6/4.8	1/60	1-4.8	Single	17.3/20.0	2.5	25/29	25/30
	RXHJ-24B/T08J	5.4/7.2	1/60	2-3.6	Single	26.0/30.0	2.5	36/41	40/45
	RXHJ-24B/T10J	7.2/9.6	1/60	2-4.8	Single	34.6/40.0	2.5	47/54	50/60

- Electric heater BTUH - (heater watts + motor watts) x 3.414 (see airflow table for motor watts.)
- Supply circuit protective devices may be fused or "HACR" type circuit breakers.
- If non-standard fuse size is specified, use next size larger standard fuse size.
- Largest motor load is included in single circuit or circuit 1 of multiple circuits.
- No electrical heating elements are permitted to be used with A Voltage (115V) air handler.

- J voltage (230V) single phase air handler is designed to be used with single or three phase 230 volt electric heaters. In the case of connecting 3 phase power to air handler terminal block without the heater, bring only two leads to terminal block, cap, insulate and fully secure the third lead.
- Do not use 480 volts electrical heaters on 230 volts air handler.

## Electrical Wiring:

### Power Wiring

- Field wiring must comply with the National Electrical Code (C.E.C. in Canada) and any applicable local ordinance.
- Supply wiring must be 75°C minimum copper conductors only.
- See electrical data for product Ampacity rating and Circuit Protector requirement.

### Grounding

- This product must be sufficiently grounded in accordance with National Electrical Code (C.E.C. in Canada) and any applicable local ordinance.
- A grounding lug is provided.

[ ] Designates Metric Conversions

## 16.0 Accessories-Kits-Parts

- **Drain Pan Over Flow Switch RXHK-A01** is used to detect condensate drain blockage and will shut down the outdoor unit in order to prevent structural damage to the surrounding structures of the air handler.

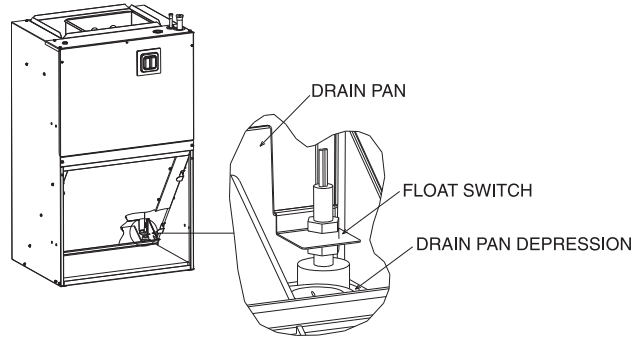

- **Bottom Return Conversion Kit RXHK-** is used to divert the return air from the factory standard front return to a bottom return.

Accessory Number	Indoor Unit
RXHK-B01	RF1P-FR18
	RF1P-FR24
	RF1T-FR24
RXHK-B02	RF1P-FR30
	RF1P-FR36
	RF1T-FR36

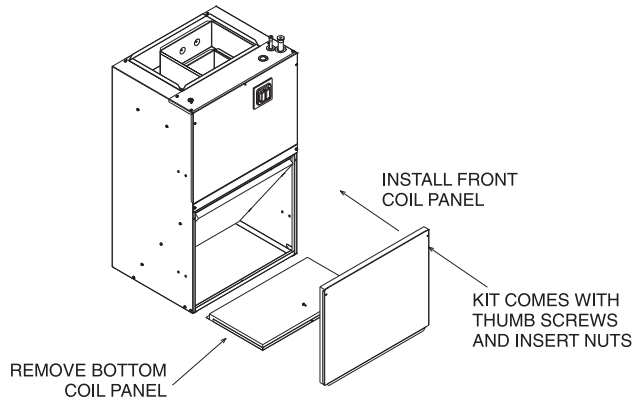

- **Louvered Cabinet Grill RXHK-** is used as a decorative grill which covers the return air opening of the front return air handler.

Accessory Number	Indoor Unit
RXHK-C01	RF1P-FR18
	RF1P-FR24
	RF1T-FR24
RXHK-C02	RF1P-FR30
	RF1P-FR36
	RF1T-FR36

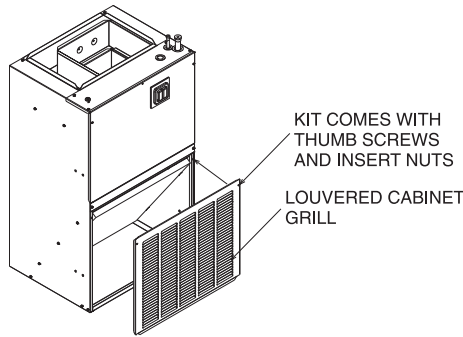

- **Decorative Wall Grill RXHK-D01 or RXHK-D02** is used in applications where the air handler is installed in a closet or interior wall and allows adequate return air back to the unit. Please refer to RXHD-D01/RXHK-D02 installation instructions for complete dimensional information when selecting a decorative wall grill.

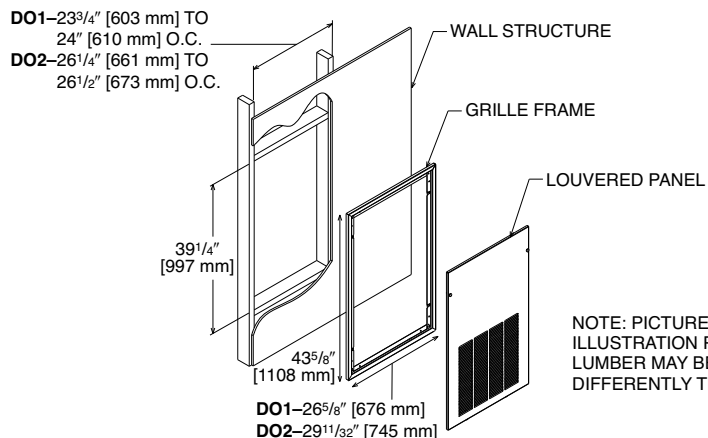

[ ] Designates Metric Conversions

**GENERAL TERMS OF LIMITED WARRANTY\***

Ruud will furnish a replacement for any part of this product which fails in normal use and service within the applicable periods stated, in accordance with the terms of the limited warranty.

Conditional Parts (Registration Required) .....Ten (10) Years

**\*For complete details of the Limited and Conditional Warranties, including applicable terms and conditions, contact your local contractor or the Manufacturer for a copy of the product warranty certificate.**







*In keeping with its policy of continuous progress and product improvement, Ruud reserves the right to make changes without notice.*

Ruud Heating, Cooling & Water Heating • 5600 Old Greenwood Road  
Fort Smith, Arkansas 72908 • [www.ruud.com](http://www.ruud.com)

Ruud Canada • 125 Edgeware Road, Unit 1  
Brampton, Ontario • L6Y 0P5

**RELY ON RUUD.™**

PRINTED IN U.S.A. 3/19 QG FORM NO. H22-555 REV. 3