



# SINGLE-ZONE CEILING-CONCEALED DUCTED SYSTEM ENGINEERING MANUAL

## Single-Zone Ceiling-Concealed Ducted Heat Pump Systems 3/4 to 3 Tons



Low Static  
LD097HV4 (9,000 Btu/h)  
LD127HV4 (12,000 Btu/h)  
LD187HV4 (18,000 Btu/h)

High Static  
LH248HV4 (24,000 Btu/h)

High Static  
LH368HV4 (36,000 Btu/h)

## **PROPRIETARY DATA NOTICE**

**This document, as well as all reports, illustrations, data, information, and other materials are the property of LG Electronics U.S.A., Inc., and are disclosed by LG Electronics U.S.A., Inc. only in confidence.  
This document is for design purposes only.**

A summary list of safety precautions is on page 4.

**For more technical materials such as submittals, catalogs, installation, owner's, and service manuals, visit [www.lghvac.com](http://www.lghvac.com).**

# TABLE OF CONTENTS

<b>Unit Nomenclature</b> .....	<b>4</b>
<b>LG Air Conditioner Technical Solution (LATS)</b> .....	<b>5-6</b>
<b>Ducted System Data</b> .....	<b>7-51</b>
<i>Mechanical Specifications</i> .....	8-9
<i>General Data</i> .....	10-12
<i>Electrical Data</i> .....	13
<i>Functions, Controls, and Options</i> .....	14-15
<i>Dimensions</i> .....	16-21
<i>Acoustic Data</i> .....	22-25
<i>Refrigerant Flow Diagrams</i> .....	26-32
<i>Wiring Diagrams</i> .....	33-39
<i>Electrical Connections</i> .....	40-46
<i>External Static Pressure</i> .....	47-48
<i>Accessories</i> .....	49-51
<b>Performance Data</b> .....	<b>52-64</b>
<i>Cooling Capacity Tables</i> .....	53-57
<i>Heating Capacity Tables</i> .....	58-62
<i>Maximum Heating Capacity Tables</i> .....	63-64
<b>Application Guidelines</b> .....	<b>65-83</b>
<i>Equipment Selection Procedure</i> .....	66-67
<i>Placement Considerations</i> .....	68-77
<i>Clearances</i> .....	78-80
<i>Installing Outdoor Unit Indoors</i> .....	81-82
<i>Refrigerant Piping Design</i> .....	83

## TABLE OF SYMBOLS

 <b>DANGER</b>	<i>This symbol indicates an imminently hazardous situation which, if not avoided, will result in death or serious injury.</i>
 <b>WARNING</b>	<i>This symbol indicates a potentially hazardous situation which, if not avoided, could result in death or serious injury.</i>
 <b>CAUTION</b>	<i>This symbol indicates a potentially hazardous situation which, if not avoided, may result in minor or moderate injury.</i>
<b>Note:</b>	<i>This symbol indicates situations that may result in equipment or property damage accidents only.</i>
	<i>This symbol indicates an action that must not be performed.</i>

# UNIT NOMENCLATURE

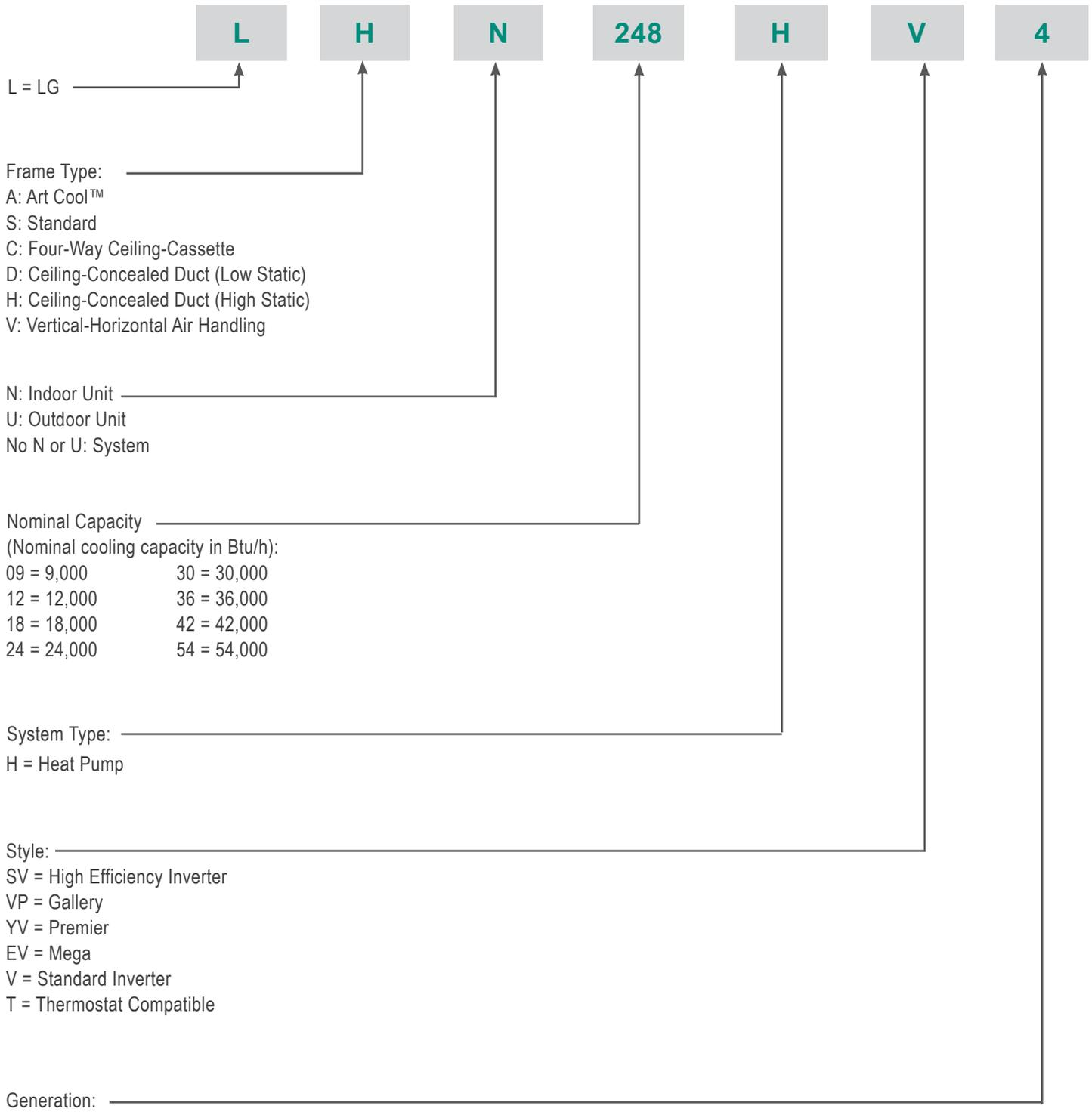

# LG AIR CONDITIONER TECHNICAL SOLUTION (LATS)

## LG Air Conditioner Technical Solution (LATS) Software

A properly designed and installed refrigerant piping system is critical to the optimal performance of LG air-conditioning systems. To assist engineers, LG offers, free of charge, LG Air Conditioner Technical Solution (LATS) software—a total design solution for LG air conditioning systems. Contact your LG Rep for the best software program for your application.

### Note:

To reduce the risk of designing an improper applied system or one that will not operate correctly, LG requires that LATS software be used on all projects.

### Formats

LATS is available to LG customers in three user interfaces: LATS HVAC, LATS CAD2, and LATS Revit. All three LATS formats are available through [www.myLGHVAC.com](http://www.myLGHVAC.com), or contact an LG Sales Representative.

**LATS HVAC** is a Windows®-based application that aids engineers in designing LG Variable Refrigerant Flow (VRF), Multi F / Multi F MAX, Single-Zone, and Energy Recovery Ventilator (ERV) systems.

\*Windows® is a registered mark of Microsoft® Corporation.

**LATS CAD2** combines the LG LATS program with AutoCAD® software\*\*. It permits engineers to layout and validate LG Multi V Variable Refrigerant Flow (VRF), Multi F / Multi F MAX, Single-Zone, and Energy Recovery Ventilator (ERV) systems directly into CAD drawings.

**LATS Revit** integrates the LG LATS program with Revit® software\*\*. It permits engineers to layout and validate Multi V VRF systems directly into Revit drawings.

\*\*AutoCAD® and Revit® are both registered marks of Autodesk, Inc.

### Features

All LG product design criteria have been loaded into the program, making LATS simple to use: double click or drag and drop the component choices. Build systems in Tree Mode where the refrigerant system can be viewed. Switch to a Schematic diagram to see the electrical and communications wiring.

LATS software permits the user to input region data, indoor and outdoor design temperatures, modify humidity default values, zoning, specify type and size of outdoor units and indoor units, and input air flow and external static pressure (ESP) for ducted indoor units.

The program can also:

- Import building loads from a separate Excel file.
- Present options for outdoor unit auto selection.
- Automatically calculate component capacity based on design conditions for the chosen region.
- Verify if the height differences between the various system components are within system limits.
- Provide the correct size of each refrigerant piping segment and LG Y-Branched and Headers.
- Adjust overall piping system length when elbows are added.
- Check for component piping limitations and flag if any parameters are broken.
- Factor operation and capacity for defrost operation.
- Calculate refrigerant charge, noting any additional trim charge.
- Suggest accessories for indoor units and outdoor units.
- Run system simulation.

### Note:

Features depend on which LATS program is being used, and the type of system being designed.

Figure 1: Example of LATS CAD2.



# LG AIR CONDITIONER TECHNICAL SOLUTION (LATS)

## LATS Generates a Complete Project Report

LATS software also generates a report containing project design parameters, cooling and heating design data, system component performance, and capacity data. The report includes system combination ratio and refrigerant charge calculations; and provides detailed bill of material, including outdoor units, indoor units, control devices, accessories, refrigerant pipe sizes segregated by building, by system, by pipe size, and by pipe segments. LATS can generate an Excel GERP report that can imported into the LG SOPS pricing and ordering system.

## Proper Design to Install Procedure

LG encourages a two report design-to-install-procedure. After the design engineer determines building / zone loads and other details, the engineer opens the LATS program and inputs the project's information. When the design is complete, the "Auto Piping" and "System Check" functions must be used to verify piping sizes, limitations, and if any design errors are present. If errors are found, engineers must adjust the design, and run Auto Piping and System Check again. When the design passes the checks, then the engineer prints out a project "Shop Drawing" (LATS Tree Diagram) and provides it to the installing contractor. The contractor must follow the LATS Tree Diagram when building the piping system, but oftentimes the design changes on the building site:

- Architect has changed location and/or purpose of room(s).
- Outdoor unit cannot be placed where originally intended.
- Structural elements prevent routing the piping as planned.
- Air conditioning system conflicts with other building systems (plumbing, gas lines, etc.).

The contractor must mark any deviation from the design on the Shop Drawing, including as-built straight lines and elbows. This "Mark Up" drawing must be returned to the design engineer or Rep, who must input contractor changes into the LATS file. (Copy the original LATS software file, save and rename as a separate file, and modify all piping lengths by double-clicking on each length and editing information.) Like the shop drawing, the Auto Piping and System Check must also be run on this new "As Built" drawing. The design engineer or Rep must then provide the final As Built file to the contractor. The Mark Up version must be compared to the As Built version for the following:

- Differences in pipe diameter(s). If incorrect diameters have been installed, the piping must be changed out. If pipe diameters have changed, check to see if Y-Branches will also need to be changed.
- Changes to outdoor unit and indoor unit capacities. Capacities changes may impact line length changes.
- Additional refrigerant charge quantity ("Trim Charge"). Trim charge will change if piping lengths and diameters change. The As Built version must reflect installed piping lengths to ensure correct trim charge.

All documents submitted by the contractor, as well as the Shop Drawing and the As Built Drawing files must be provided for commissioning purposes. Model and serial numbers for all system components must also be submitted. If the steps previously detailed are not followed, and all documents are not provided to the LG Commissioner, the project runs the risk of not being commissioned and voiding any limited warranty LG offers on the equipment.

Figure 2: Example of a LATS Tree Diagram.

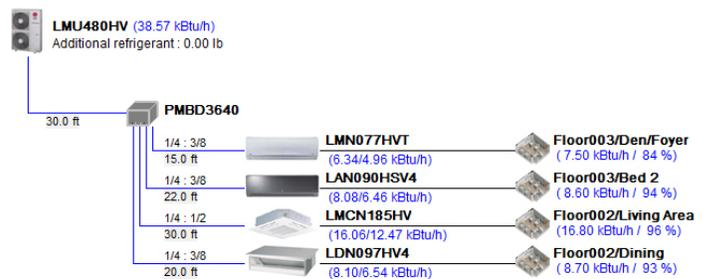

# CEILING-CONCEALED DUCTED UNIT PRODUCT DATA

**Mechanical Specifications on page 8**

**General Data on page 10**

**Electrical Data on page 13**

**Functions, Controls, and Options on page 14**

**Dimensions on page 16**

**Acoustic Data on page 22**

**Refrigerant Flow Diagrams on page 26**

**Wiring Diagrams on page 33**

**Electrical Connections on page 40**

**External Static Pressure on page 47**

**Accessories on page 49**

# MECHANICAL SPECIFICATIONS

## Ceiling-Concealed Ducted System

### General

#### System

LG single zone ceiling-concealed ducted system comprises of a single frame outdoor unit connected to a single indoor unit with a single refrigerant circuit. An LG single zone ceiling-concealed ducted system can operate in either cooling or heating mode. The system is capable of changing mode within a maximum time of three (3) minutes to ensure indoor temperature can be properly maintained. LG components are manufactured in a facility registered to ISO 9001 and ISO 14001, which is a set of standards applying to environmental protection set by the International organization for Standardization (ISO). The system components comply with Underwriters Laboratories (UL) 1995 Heating and Cooling Equipment Standard for Safety and bear the CSA label. Wiring in these units are in accordance with the national Electrical Code (NEC). LG single zone ceiling-concealed ducted systems have published performance ratings certified by AHRI (Air-Conditioning, Heating, and Refrigeration Institute) and are listed in the AHRI Standard 210/240 certified product directory.

#### Outdoor Unit

The outdoor unit has sound levels not exceeding 54 dB(A) tested in an anechoic chamber under ISO Standard 3745.

#### Indoor Unit

Ceiling-Concealed Ducted units are designed for air volume against an external static pressure up to 0.59"WG for the 24,000 Btu/h and 36,000 Btu/h model.

### Temperature Ranges

#### 9,000 and 12,000 Btu/h Low Static Operating Ranges

- Operating ranges for outdoor units of 0°F to +118°F (DB) for cooling (Cooling range can be extended from 0°F down to -4°F using the Low Ambient Wind Baffle Kit [sold separately]); -4°F to +64°F (WB) for heating.
- Operating ranges for indoor units of 57°F to 77°F (WB) for cooling; 59°F to 81°F (DB) for heating.
- Indoor unit temperature setting range of 65°F to 86°F (DB) for cooling; 61°F to 86°F (WB) for heating.

#### 18,000, 24,000, and 36,000 Btu/h Low Static Operating Ranges

- Operating ranges for outdoor units of 5°F to +118°F (DB) for cooling; -4°F to +64°F (WB) for heating.
- Operating ranges for indoor units of 57°F to 77°F (WB) for cooling; 59°F to 81°F (DB) for heating.
- Indoor unit temperature setting range of 65°F to 86°F (DB) for cooling; 61°F to 86°F (WB) for heating.
- Cooling range can be extended from 5°F down to -4°F using the Low Ambient Wind Baffle Kit (sold separately).

### Casing / Frame

#### Outdoor Unit

The outdoor condensing unit case is constructed from pre-coated metal (PCM) that has been tested in accordance with ASTM B-117 salt spray procedure for a minimum of 1,000 hours. Case has a removable panel to allow access to major internal components, and legs to secure the unit during installation.

#### Indoor Unit

The indoor unit casing is designed to mount fully concealed above a finished ceiling. Casing is manufactured of galvanized steel plate. Cold surfaces of the unit are covered internally with a coated polystyrene insulating material, and covered externally with sheet insulation made of ethylene propylene diene monomer (M-Class) (EPDM). External insulation is plenum rated and conforms to ASTM Standard D-1418. Hanger brackets are included on the casing to support the weight on four corners. The indoor unit has a front horizontal supply air discharge, and one dedicated rear horizontal return air. The supply air opening is flanged to accept field-installed ductwork that must not exceed the external static pressure limitation of the unit.

### Refrigerant System

The system is designed for use with R410A refrigerant, and consists of a single refrigeration circuit. The refrigeration circuit is pressure-tested at the factory and shipped with a holding charge of helium gas. The outdoor unit is provided with factory installed components, including a refrigerant strainer, accumulator, four-way reversing valve, electronic expansion valve (EEV), high and low side charging ports, service valves, and interconnecting piping. All refrigerant lines from the outdoor unit to the indoor unit are field-installed and must be insulated separately.

Figure 3: Ceiling-Concealed Ducted System (LH248HV4 High Static Model).



# MECHANICAL SPECIFICATIONS

## Ceiling-Concealed Ducted System

### Compressors

The 9,000 ~ 24,000 Btu/h outdoor units are equipped with one hermetically sealed, digitally controlled, inverter-driven twin rotary compressor to modulate capacity (modulation in 1 Hz increments). The 36,000 Btu/h outdoor unit is equipped with one hermetically sealed, digitally controlled, inverter-driven scroll compressor to modulate capacity (modulation in 1 Hz increments). Teflon coated bearings, overcurrent protection, and vibration isolation are integrated with the compressor.

Frequency ranges for the 9,000 ~ 36,000 Btu/h outdoor units are:

9k Btu/h = 20 Hz to 100 Hz

12k Btu/h = 20 Hz to 100 Hz

18 Btu/h = 15 to 80 Hz Cooling; 15 to 100 Hz Heating

24k Btu/h = 15 to 80 Hz Cooling; 15 to 100 Hz Heating

36k Btu/h = 15 to 120 Hz Cooling; 15 to 130 Hz Heating

### Coil

#### Outdoor Unit

Heat pump outdoor unit coils are made of nonferrous louvered aluminum fins protected with an integral coil guard. The coil for each outdoor unit has a minimum of 14 fins per inch (FPI); heat exchanger has two rows. The coil fins have a factory applied corrosion resistant GoldFin™ material with hydrophilic coating tested in accordance with ASTM B-117 salt spray test procedure for a minimum of 1,000 hours. Coils are factory tested to a pressure of 551 psig.

#### Indoor Unit

Indoor unit coils are factory built and are comprised of aluminum fins mechanically bonded to copper tubing. Each indoor unit has a minimum of three rows of coils, which are pressure tested to 551 psig at the factory. Each unit is provided with a factory installed condensate drain pan below the coil.

### Fans and Motors

#### Outdoor Unit

The 9,000 Btu/h (LUU097HV), 12,000 Btu/h (LUU127HV), 18,000 Btu/h (LUU189HV), and 24,000 Btu/h (LUU249HV) outdoor units include one direct drive, variable speed axial / propeller type fan with a horizontal air discharge; the 36,000 Btu/h outdoor unit (LUU369HV) includes two fans. Fan blades are made of Acrylonitrile Butadiene Styrene (ABS) material, and have a Brushless Digitally Controlled (BLDC) fan motor. The fan motor has inherent protection, permanently lubricated bearings, and variable speed with a maximum speed up to 950 rpm. Raised guards are provided to limit contact with moving parts.

#### Indoor Unit

The 9,000 Btu/h (LDN097HV4) indoor unit has 2 direct-drive Sirocco fans. The 12,000 Btu/h (LDN127HV4) and 18,000 Btu/h (LDN187HV4) indoor units have three direct-drive Sirocco fans. The 24,000 Btu/h (LHN248HV) indoor unit has one direct-drive Sirocco fan.

The 36,000 Btu/h (LHN368HV) indoor unit has two direct-drive, Sirocco fans made of high strength ABS GP-2200 polymeric resin. The fans are statically and dynamically balanced, mounted on a common brushless digitally controlled (BLDC) motor, and mounted on vibration-attenuating rubber grommets. Fan speed is controlled using a microprocessor-based direct digital control algorithm. The indoor fan has Low, Med, High, and Auto settings for Cooling mode; and has Low, Med, High, and Auto settings for Heating mode. The Auto setting adjusts the fan speed based on the difference between the controller set-point and space temperature.

### Air Filter - Indoor Unit

The return air inlet on the indoor unit includes a factory-supplied removable, washable filter that is accessible from the back of the unit. Options include a return filter box that holds a field-provided high efficiency one or two inch MERV-rated filters, and a LG-supplied air cleaner (each sold separately).

### Electrical

The system is designed to operate using 208–230 / 60 / 1 power with voltage variances of  $\pm 10\%$  and includes overcurrent protection. The indoor unit is powered through the outdoor unit.

### Controls

Indoor and outdoor units are factory wired with necessary electrical control components, printed circuit boards, thermistors, sensors, terminal blocks, and lugs for power wiring. Factory installed microprocessor controls in the outdoor unit and indoor unit perform functions to efficiently operate the single zone system, communicating via an 14 AWG four stranded and shielded conductor power/transmission cable. Microprocessor-based algorithms provide component protection, soft-start capability, refrigeration system pressure, temperature, defrost, and ambient control. System can be operated through a simple wired remote controller (required, but sold separately).

### Condensate Lift/Pump

The indoor unit is provided with a factory installed and wired condensate lift/pump capable of providing a minimum 27-9/16 inch lift from the bottom surface of the unit. Drain pump has a safety switch to shut off the indoor unit if the condensate rises too high in the drain pan.

Figure 4: Ceiling-Concealed Ducted System (LD187HV4 Low Static Model).



# GENERAL DATA

## Ceiling Concealed Ducted Pairing Table

The following table shows the available outdoor and indoor unit.

Table 1: Ceiling-Concealed Ducted System Pairing Table

Outdoor Unit Model	Indoor Unit Model
<i>Low Static</i>	
LUU097HV LUU127HV 	LDN097HV4 LDN127HV4 
LUU189HV 	LDN187HV4 
<i>High Static</i>	
LUU249HV 	LHN248HV 
LUU369HV 	LHN368HV 

### Note:

The above units require any LG wired remote controller for operation. The LG wired remote controller is sold separately.

# GENERAL DATA / SPECIFICATIONS

## Low Static Ducted

Table 2: Ceiling-Concealed Ducted (Low Static) System General Data.

Type	Single Zone Ceiling-Concealed Ducted (Low Static)		
System (Model) (Indoor Unit / Outdoor Unit)	LD097HV4 (LDN097HV4 / LUU097HV)	LD127HV4 (LDN127HV4 / LUU127HV)	LD187HV4 (LDN187HV4 / LUU189HV)
Cooling Capacity (Min / Rated / Max) (Btu/h)	3,600 ~ 9,000 ~ 9,900	4,640 ~ 11,600 ~ 12,760	7,400 ~ 18,000 ~ 21,100
Cooling Power Input <sup>1</sup> (kW)	0.20 ~ 0.71 ~ 0.89	0.26 ~ 0.9 ~ 1.13	0.55 ~ 1.56 ~ 2.00
EER (OD 95°F)	12.7	12.9	11.5
SEER	18.5	19.6	18
Heating Capacity (Min / Rated / Max) (Btu/h)	5,600 ~ 14,000 ~ 15,400	6,400 ~ 16,000 ~ 17,600	6,800 ~ 20,000 ~ 21,800
Heating Power Input <sup>1</sup> (kW)	0.26 ~ 1.43 ~ 1.80	0.37 ~ 1.29 ~ 1.63	0.52 ~ 2.00 ~ 2.10
COP (OD 47°F)	2.86	3.64	2.93
HSPF	10.3	10.5	10
<b>Rated Low Heating Capacity (Btu/h)</b>			
Outdoor 17°F (WB)/Indoor 70°F (DB)	9,500	10,000	12,700
Low COP (OD 17°F)	2.54	2.7	2.42
<b>Maximum Heating Capacity (Btu/h)</b>			
Outdoor 17°F (DB) / Indoor 70°F (DB)	11,900 (85%)	13,600 (85%)	18,000 (90%)
Outdoor 5°F (DB) / Indoor 70°F (DB)	10,500 (75%)	12,000 (75%)	16,000 (80%)
Outdoor -4°F (DB) / Indoor 70°F (DB)	8,960 (64%)	10,240 (64%)	14,000 (70%)
Power Supply V, Ø, Hz <sup>2</sup>	208-230 / 1 / 60		
<b>Outdoor Unit Operating Range</b>			
Cooling (°F DB)	0 to 118 <sup>6</sup>	0 to 118 <sup>6</sup>	5 to 118 <sup>6</sup>
Heating (°F WB)	-4 to 64	-4 to 64	-4 to 64
<b>Indoor Unit Operating Range</b>			
Cooling (°F WB)	57 to 77	57 to 77	57 to 77
Heating (°F DB)	59 to 81	59 to 81	59 to 81
<b>Indoor Temperature Setting Range</b>			
Cooling (°F DB)	65 to 86		
Heating (°F WB)	61 to 86		
<b>Unit Data</b>			
Refrigerant Type <sup>3</sup>	R410A		
Refrigerant Control	EEV		
Indoor Unit Sound Pressure Level dB(A) (H/M/L) <sup>4</sup>	30 / 26 / 23	31 / 28 / 27	36 / 34 / 31
Outdoor Unit Sound Pressure Level dB(A) (Cool/Heat) <sup>4</sup>	47 / 51	49 / 52	48 / 52
Indoor Unit Net / Shipping Weight (lbs.)	38.6 / 45.2	50.7 / 59.5	48.5 / 57.3
Outdoor Unit Net / Shipping Weight (lbs.)	81.5 / 88.2	81.5 / 88.2	127.8 / 140.0
Power Wiring / Communications Cable (No. x AWG) <sup>2</sup>	4 x 14		
Compressor (Type x Qty.)	Twin Rotary x 1	Twin Rotary x 1	Twin Rotary x 1
Dehumidification Rate (pts./hr.)	1.5	2.28	2.4
<b>Fan</b>			
Indoor Unit Type x Qty.	Sirocco x 2	Sirocco x 3	Sirocco x 3
Outdoor Unit Type x Qty.	Propeller x 1	Propeller x 1	Propeller x 1
Motor / Drive	Brushless Digitally Controlled / Direct		
<b>Airflow Rate</b>			
Indoor Unit (H / M / L [CFM])	318 / 247 / 194	353 / 300 / 247	530 / 441 / 353
Outdoor Unit (CFM)	988	988	2,048
<b>Piping</b>			
Liquid (in.) (Connection size / Pipe size)	1/4 / 1/4		1/4 / 3/8
Vapor (in.) (Connection size / Pipe size)	3/8 / 3/8		1/2 / 5/8
Indoor Unit Condensate Drain O.D. / I.D. (in.)	1-1/4 / 1		1-1/4 / 1
Additional Refrigerant Charge (oz./ft.)	0.22		0.43
Maximum Pipe Length (ft.)	66		164
Piping Length <sup>5</sup> (no additional refrigerant, ft.)	24.6		24.6
Maximum Elevation Difference (ft.)	49		98.4

EEV: Electronic Expansion Valve, IDU: Indoor Unit, ODU: Outdoor Unit. This unit comes with a dry helium charge.  
 This data is rated 0 ft above sea level, with 24.6 ft of refrigerant line per indoor unit and a 0 ft level difference between outdoor and indoor units.  
 Cooling capacity rating obtained with air entering the indoor coil at 80°F dry bulb (DB) and 67°F wet bulb (WB); and outdoor ambient conditions of 95°F dry bulb (DB) and 75°F wet bulb (WB).  
 Heating capacity rating obtained with air entering the indoor unit at 70°F dry bulb (DB) and 60°F wet bulb (WB); and outdoor ambient conditions of 47°F dry bulb (DB) and 43°F wet bulb (WB).  
<sup>1</sup>Power Input is rated at high speed.  
<sup>2</sup>All power wiring/communication cables from ODU to IDU are field supplied and are to be minimum 14 AWG, 4-conductor, stranded, shielded or unshielded (if shielded, must be grounded to chassis at

ODU only), and must comply with applicable local and national codes.  
<sup>3</sup>Take appropriate actions at the end of HVAC equipment life to recover, recycle, reclaim or destroy R410A refrigerant according to applicable regulations (40 CFR Part 82, Subpart F) under section 608 of CAA.  
<sup>4</sup>Sound pressure levels are tested in an anechoic chamber under ISO Standard 3745 and are the same in both cooling and heating mode. These values can increase due to ambient conditions during operation.  
<sup>5</sup>Piping lengths are equivalent.  
<sup>6</sup>Cooling range can be extended from 0°F/ 5°F down to -4°F using the Low Ambient Wind Baffle Kit (sold separately).



# GENERAL DATA / SPECIFICATIONS

## High Static Ducted

Table 3: Ceiling-Concealed Ducted (High Static) System General Data.

Type System (Model) (Indoor Unit / Outdoor Unit)	Single Zone Ceiling-Concealed Ducted (High Static)	
	LH248HV4 (LHN248HV / LUU249HV)	LH368HV4 (LHN368HV / LUU369HV)
Cooling Capacity (Min / Rated / Max) (Btu/h)	9,600 ~ 24,000 ~ 27,000	14,400 ~ 36,000 ~ 41,400
Cooling Power Input <sup>1</sup> (kW)	0.72 ~ 2.00 ~ 4.00	0.72 ~ 2.98 ~ 4.00
EER (OD 95°F)	12.0	12.1
SEER	19.0	19.0
Heating Capacity (Min / Rated / Max) (Btu/h)	10,800 ~ 27,000 ~ 30,000	16,000 ~ 40,000 ~ 42,200
Heating Power Input <sup>1</sup> (kW)	0.58 ~ 2.08 ~ 3.10	0.77 ~ 3.08 ~ 3.50
COP (OD 47°F)	3.81	3.81
HSPF	10.5	9.7
Power Supply V, Ø, Hz <sup>2</sup>	208-230 / 1 / 60	
<b>Rated Low Heating Capacity (Btu/h)</b>		
Outdoor 17°F (WB) / Indoor 70°F (DB)	17,500	24,000
Low COP (OD 17°F)	2.73	2.69
<b>Maximum Heating Capacity (Btu/h)</b>		
Outdoor 17°F (DB) / Indoor 70°F (DB)	26,000	41,500
Outdoor 5°F (DB) / Indoor 70°F (DB)	23,600	35,000
Outdoor -4°F (DB) / Indoor 70°F (DB)	20,760	27,310
<b>Outdoor Unit Operating Range</b>		
Cooling (°F DB)	5 to 118	
Optional Wind Baffle Cooling (°F DB)	Yes (-4)	
Heating (°F WB)	-4 to 64	
<b>Indoor Unit Operating Range</b>		
Cooling (°F WB)	57 to 77	
Heating (°F DB)	59 to 81	
<b>Indoor Temperature Setting Range</b>		
Cooling (°F)	65 to 86	
Heating (°F)	61 to 86	
<b>Unit Data</b>		
Refrigerant Type <sup>3</sup>	R410A	
Refrigerant Control	EEV	
Indoor Unit Sound Pressure Level ±1 dB(A) (H/M/L) <sup>4</sup>	37 / 35 / 34	44 / 42 / 40
Outdoor Unit Sound Pressure Level ±1 dB(A) (Cool/Heat) <sup>4</sup>	48 / 52	52 / 54
Indoor Unit Net / Shipping Weight (lbs.)	58.6 / 71.9	85.3 / 99.4
Outdoor Unit Net / Shipping Weight (lbs.)	130.0 / 143.3	198.9 / 223.1
Power Wiring / Communications Cable (No. x AWG) <sup>2</sup>	4 x 14	
Compressor (Type x Qty.)	Twin Rotary x 1	Scroll x 1
Dehumidification Rate (pts./hr.)	5.1	5.9
<b>Fan</b>		
Indoor Unit Type x Qty.	Sirocco x 1	Sirocco x 2
Outdoor Unit Type x Qty.	Propeller x 1	Propeller x 2
Motor / Drive	Brushless Digitally Controlled / Direct	
<b>Airflow Rate</b>		
Indoor Unit (Max. / H / M / L [CFM])	777 / 706 / 636	1,130 / 989 / 848
Outdoor Unit (CFM)	2,048	3,884
Factory Set (High) External Static Pressure (in. wg)	0.24	
<b>Piping</b>		
Liquid (in.) (Connection size / Pipe size)	3/8 / 3/8	
Vapor (in.) (Connection size / Pipe size)	5/8 / 5/8	
Indoor Unit Condensate Drain O.D. / I.D. (in.)	1-1/4 / 1	
Additional Refrigerant Charge (oz./ft.)	0.43	
Maximum Pipe Length (ft.)	164	246
Piping Length (no additional refrigerant, ft.)	24.6	
Maximum Elevation Difference (ft.)	98.4	

EEV: Electronic Expansion Valve, IDU: Indoor Unit, ODU: Outdoor Unit. This unit comes with a dry helium charge.

This data is rated 0 ft above sea level, with 24.6 ft of refrigerant line per indoor unit and a 0 ft level difference between outdoor and indoor units.

Cooling capacity rating obtained with air entering the indoor coil at 80°F dry bulb (DB) and 67°F wet bulb (WB); and outdoor ambient conditions of 95°F dry bulb (DB) and 75°F wet bulb (WB). Heating capacity rating obtained with air entering the indoor unit at 70°F dry bulb (DB) and 60°F wet bulb (WB); and outdoor ambient conditions of 47°F dry bulb (DB) and 43°F wet bulb (WB).

1 Power Input is rated at high speed.

2 All power wiring / communication cables from ODU to IDU are field supplied and are to be minimum

four-conductor, 14 AWG, stranded, shielded or unshielded (if shielded, it must be grounded to the chassis of ODU only), and must comply with applicable local and national codes.

3 Take appropriate actions at the end of HVAC equipment life to recover, recycle, reclaim or destroy R410A refrigerant according to applicable regulations (40 CFR Part 82, Subpart F) under section 608 of CAA.

4 Sound pressure levels are tested in an anechoic chamber under ISO Standard 3745 and are the same in both cooling and heating mode. These values can increase due to ambient conditions during operation.

5 Piping lengths are equivalent.

# ELECTRICAL DATA

## Electrical Data

Table 4: Electrical Data.

Nominal Tons	Unit Model No.	Hertz	Voltage	Voltage Range (Min. to Max.)	MCA	MOP	Compressor Quantity	Compressor Motor RLA (Cooling)	Condenser Fan Motor(s)	
									Condenser Fan Quantity.	Condenser Fan Motor FLA
<i>Low Static</i>										
3/4	LUU097HV	60	208 - 230	187 - 253	11.9	15	1	9.0	1	0.25
1	LUU127HV				12.3					
1.5	LUU189HV				20	30		13.5		
<i>High Static</i>										
2	LUU249HV	60	208 - 230	187 - 253	20	30	1	13.5	1	1.6
3	LUU369HV				32	40		22	2	1.6 x 2

Voltage tolerance is ±10%.

Maximum allowable voltage unbalance is 2%.

RLA = Rated Load Amps.

MCA = Minimum Circuit Ampacity.

Maximum Overcurrent Protection (MOP) is calculated as follows:  
 (Largest motor FLA x 2.25) + (Sum of other motor FLA) rounded down to the nearest standard fuse size.

# FUNCTIONS, CONTROLS, AND OPTIONS

## Indoor Unit

### Functions, Controls, and Options for LDN097HV4, LDN127HV4, LDN187HV4, LHN248HV, LHN368HV

Table 5: Indoor Unit—Functions, Controls, and Options.

Indoor Unit Type		Ceiling Concealed Ducted (Low Static)	Ceiling Concealed Ducted (High Static)	
Air-flow	Air supply outlets	1	2	
	Airflow steps (fan/cool/heat)	3 / 3 / 3	3 / 3 / 3	
	Washable anti-fungal filter <sup>1</sup>	√	√	
Operation	Drain pump	√	√	
	E.S.P. control	√	√	
	Hot Start	√	√	
	Self diagnostics	√	√	
	Auto changeover	√	√	
	Auto restart	√	√	
	Child lock	√	√	
	Sleep mode	√	√	
	Timer (on/off)	√	√	
	Weekly schedule	√	√	
	Two thermistor control	o	o	
	Controllers	7-Day programmable controller	o	o
		Simple wired remote controller	o	o
Wireless LCD remote control <sup>2</sup>		o	o	
Dry contact		o	o	
Dry contact (temperature setting)		o	o	
Central control (LGAP)		√	√	
Special Functions	Wi-Fi <sup>3</sup>	o	o	
	Auxiliary Heater Relay Kit (PRARH1)	o	o	

<sup>1</sup>Primary washable filters.

√ = Standard feature

<sup>2</sup>Requires wired zone controller.

o = Unit option

<sup>3</sup>Requires Wi-Fi module PWFMD200.

# FUNCTIONS, CONTROLS, AND OPTIONS

Outdoor Unit

## Functions, Controls, and Options for LUU097HV, LUU127HV, LUU189HV, LUU249HV, LUU369HV

Table 6: Outdoor Unit—Functions, Controls, and Options.

Outdoor Unit						
Category	Functions	LUU097HV	LUU127HV	LUU189HV	LUU249HV	LUU369HV
Reliability	Defrost / Deicing	O	O	O	O	O
	High pressure sensor	O	O	O	O	O
	Phase protection	X	X	X	X	X
	Restart delay (3-minutes)	O	O	O	O	O
	Self diagnosis	O	O	O	O	O
	Soft start	O	O	O	O	O
Convenience	Night Quiet Operation	O	O	O	O	O
	Mode Lock	O	O	O	O	O
	Pump Down (Forced Cooling Operation)	O	O	O	O	O
	Network solution (LGAP)	O	O	O	O	O
Central Controller	AC Smart 5	PACS5A000	PACS5A000	PACS5A000	PACS5A000	PACS5A000
	ACP 5	PACP5A000	PACP5A000	PACP5A000	PACP5A000	PACP5A000
	PI485	PMNFP14A1	PMNFP14A1	PMNFP14A1	PMNFP14A1	PMNFP14A1
Remote Controller	MultiSITE CRC1	PREMTBVC0	PREMTBVC0	PREMTBVC0	PREMTBVC0	PREMTBVC0
	MultiSITE CRC1+	PREMTBVC1	PREMTBVC1	PREMTBVC1	PREMTBVC1	PREMTBVC1
Integration Solution	MultiSITE Communications Manager	PBACNBTR0A	PBACNBTR0A	PBACNBTR0A	PBACNBTR0A	PBACNBTR0A

√ = Standard feature

O = Unit option

X = Not Available

Product Data

# OUTDOOR UNIT DIMENSIONS

## Dimensions for LUU097HV, LUU127HV

Figure 5: LUU097HV, LUU127HV Dimensions.

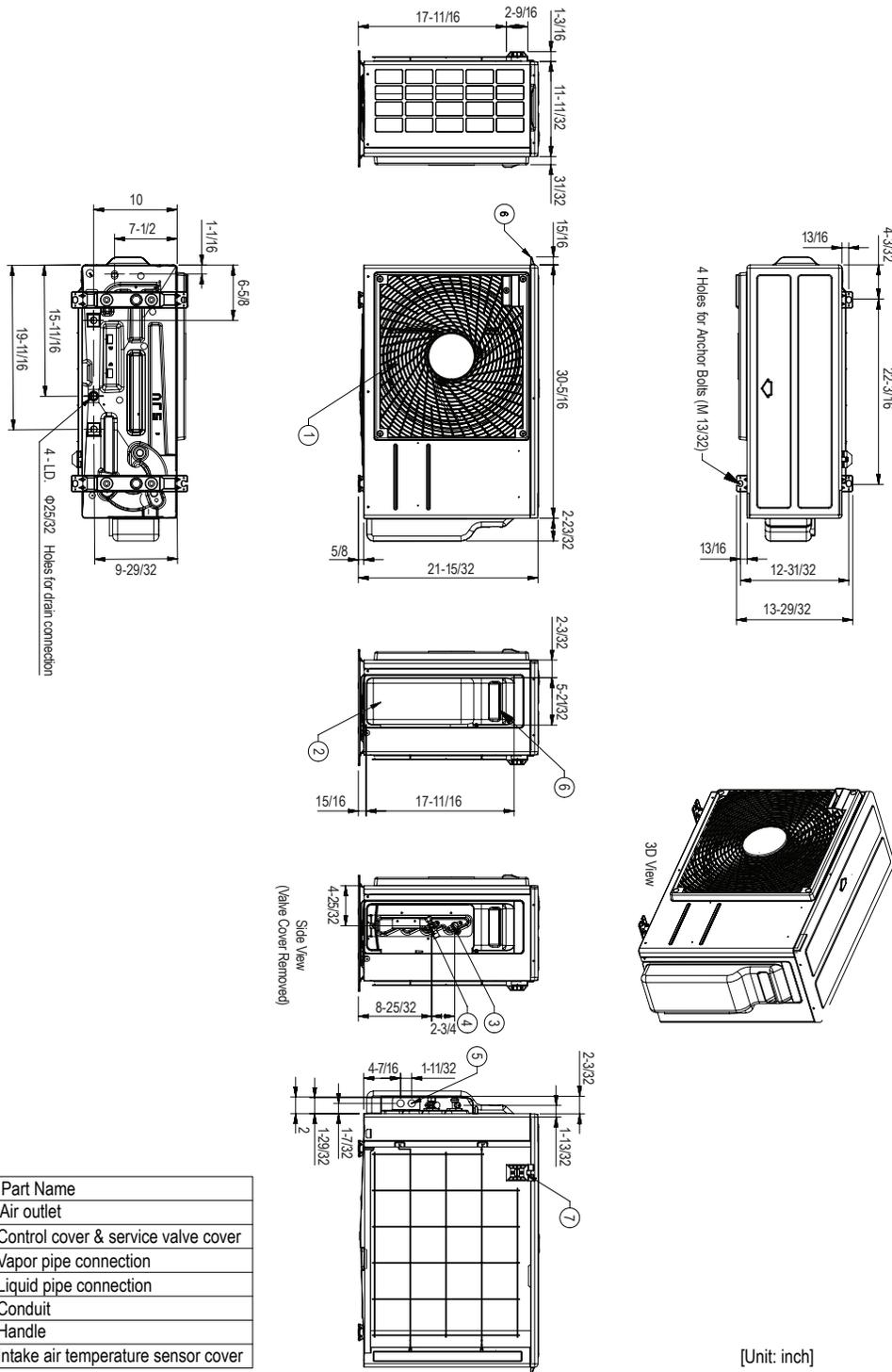

No.	Part Name
1	Air outlet
2	Control cover & service valve cover
3	Vapor pipe connection
4	Liquid pipe connection
5	Conduit
6	Handle
7	Intake air temperature sensor cover

# OUTDOOR UNIT DIMENSIONS

## Dimensions for LUU189HV, LUU249HV

Figure 6: LUU189HV, LUU249HV Dimensions.

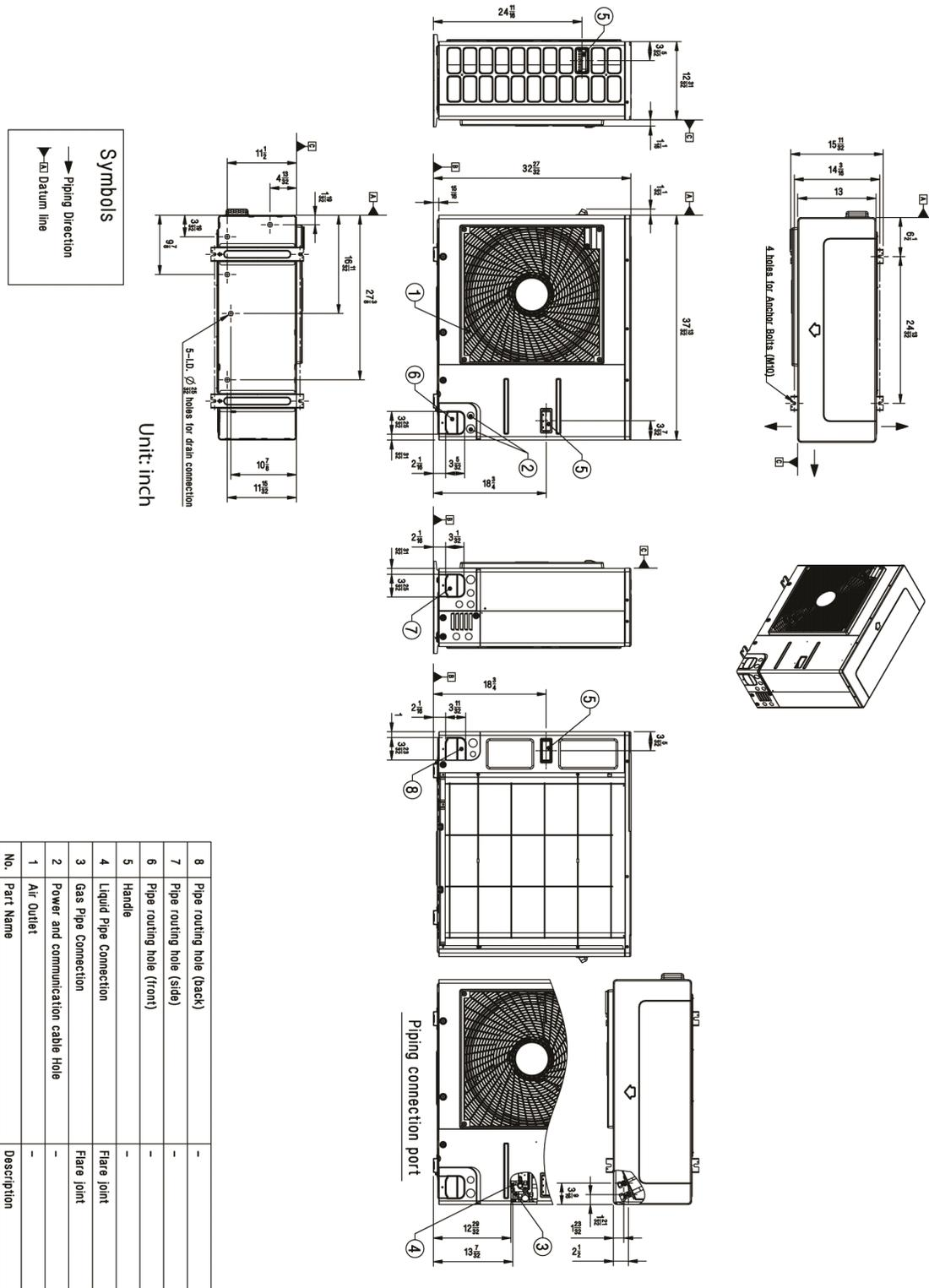

# OUTDOOR UNIT DIMENSIONS

## Dimensions for LUU369HV

Figure 7: LUU369HV Unit Dimensions.

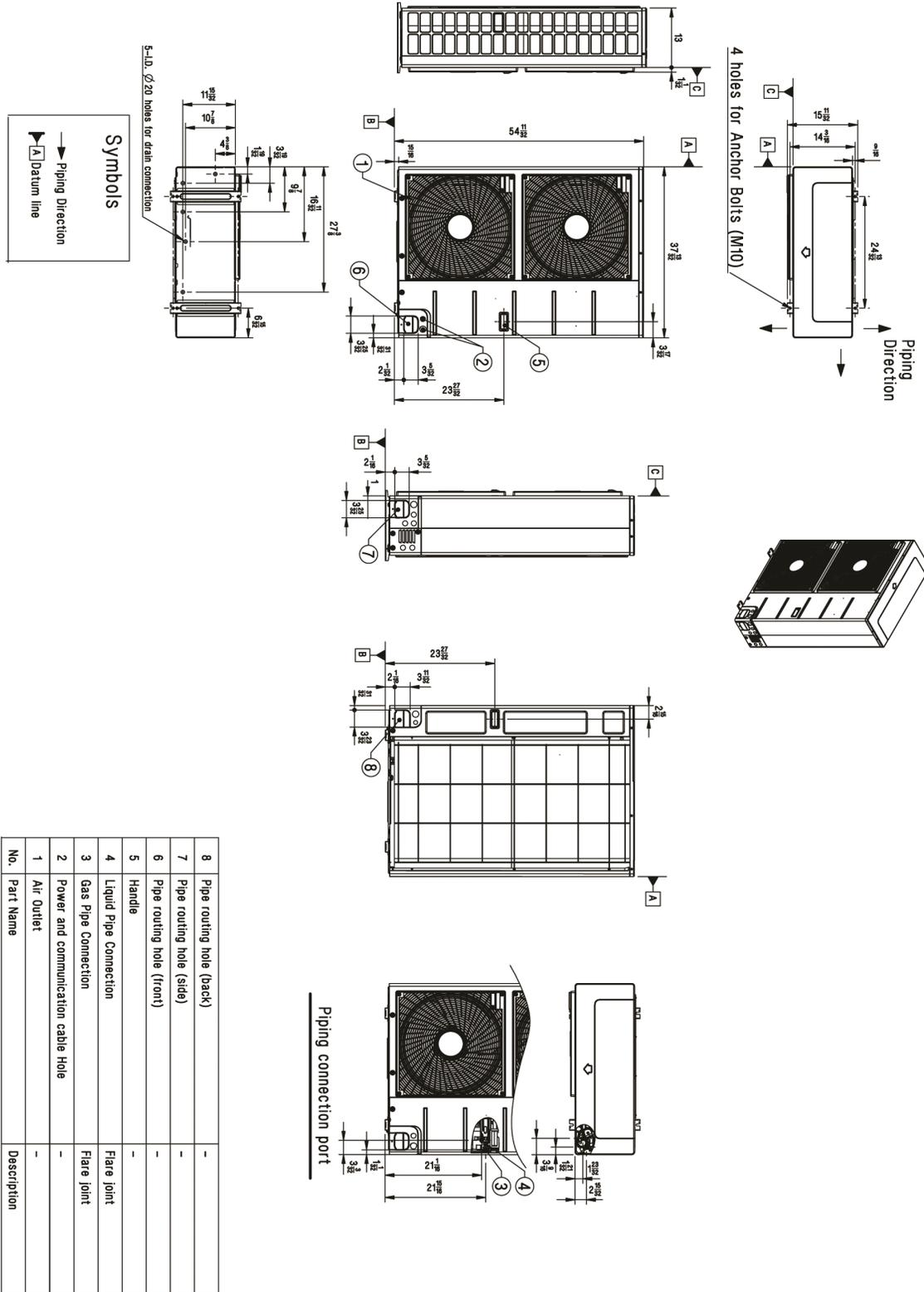

# INDOOR UNIT DIMENSIONS

## Dimensions for LDN097HV4, LDN127HV4, LDN187HV4

Figure 8: LDN097HV4, LDN127HV4, LDN187HV4 Indoor Unit Dimensions.

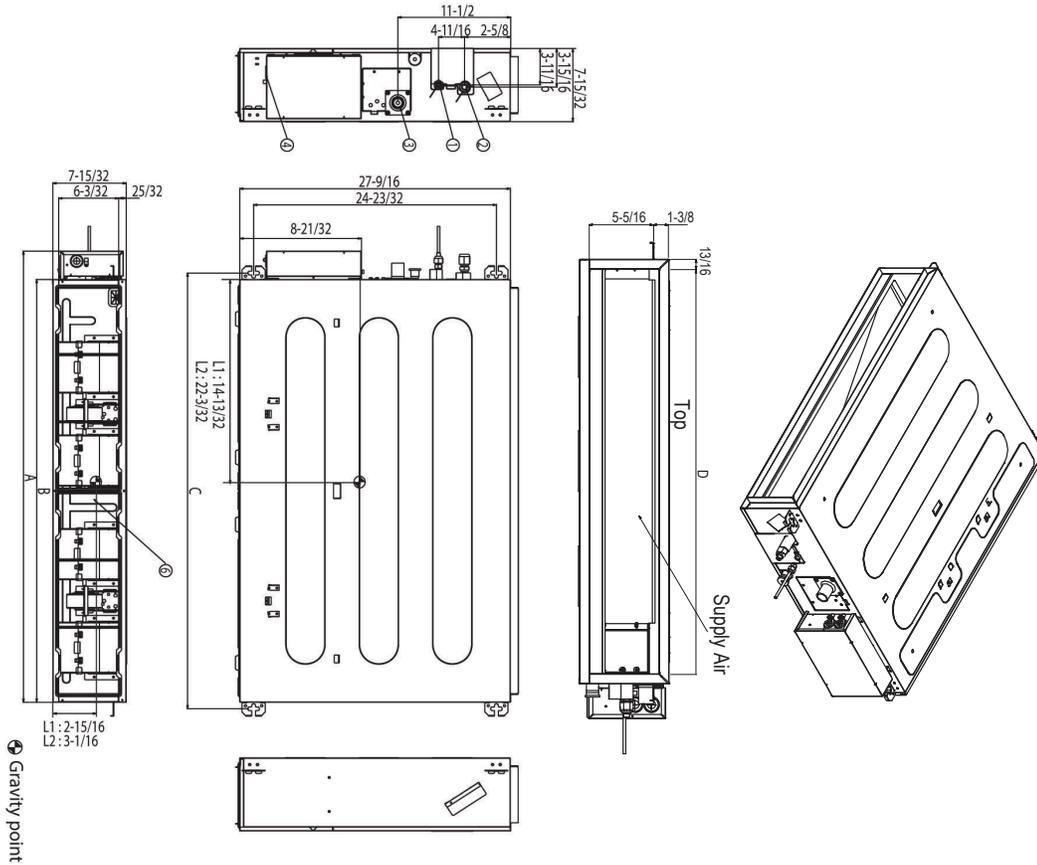

Number	Name	Description
1	Liquid pipe connection	
2	Gas pipe connection	
3	Drain pipe connection	
4	Power supply connection	
5	Air discharge	
6	Air suction	

(unit: inch)

Model Number	A	B	C	D
LDN097HV4	30-15/32	27-9/16	28-27/32	25-31/32
LDN127HV4 LDN187HV4	38-11/32	35-7/16	36-23/32	33-27/32

(unit: inch)



# INDOOR UNIT DIMENSIONS

## Dimensions for LHN368HV

Figure 10: LHN368HV Indoor Unit Dimensions.

[Unit: inch]

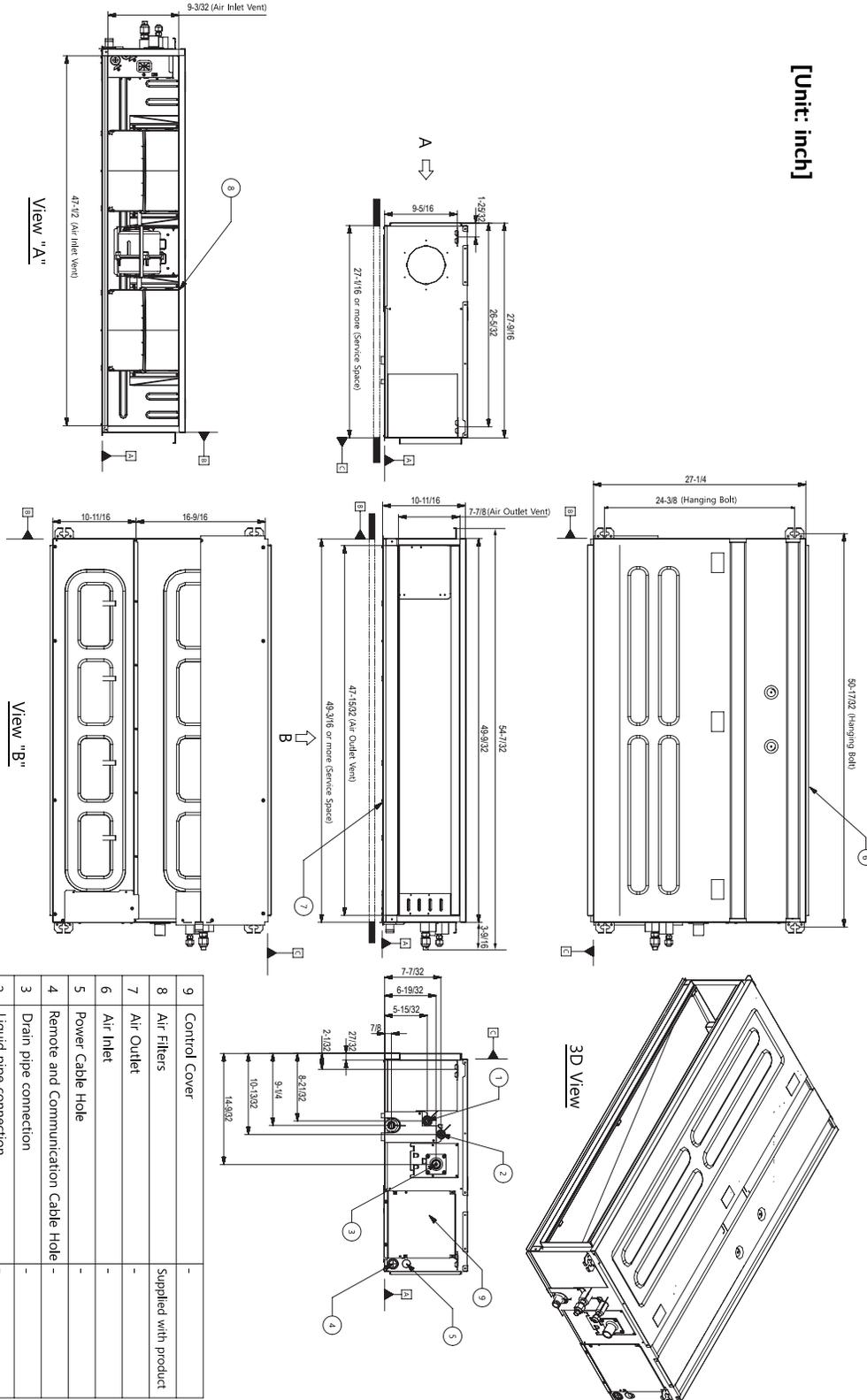

No.	Part Name	Description
9	Control Cover	-
8	Air Filters	Supplied with product
7	Air Outlet	-
6	Air Inlet	-
5	Power Cable Hole	-
4	Remove and Communication Cable Hole	-
3	Drain pipe connection	-
2	Liquid pipe connection	-
1	Gas pipe connection	-

# ACOUSTIC DATA

## Sound Pressure for Outdoor Units

### Outdoor Unit Sound Pressure Level Measurement

Figure 11: Ceiling-Concealed Ducted Outdoor Unit Sound Pressure Level Measurement Location.

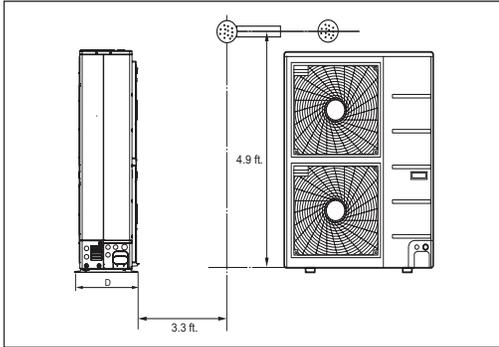

- Measurements taken with no attenuation and units operating at full load normal operating condition.
- Sound level will vary depending on a range of factors such as construction (acoustic absorption coefficient) of particular area in which the equipment is installed.
- Sound power levels are measured in dB(A)±1.
- Tested in anechoic chamber per ISO Standard 3745.

### Outdoor Unit Sound Pressure Levels

Table 7: Ceiling-Concealed Ducted Outdoor Unit Sound Pressure Levels (dB[A]).

Model	Sound Pressure Levels (dB[A])	
	Cooling	Heating
<i>Low Static</i>		
LUU097HV	47	51
LUU127HV	49	52
LUU189HV	48	52
<i>High Static</i>		
LUU249HV	48	52
LUU369HV	52	54

### Outdoor Unit Sound Pressure Diagrams

Figure 12: Ducted Outdoor Unit Sound Pressure Level Diagrams.

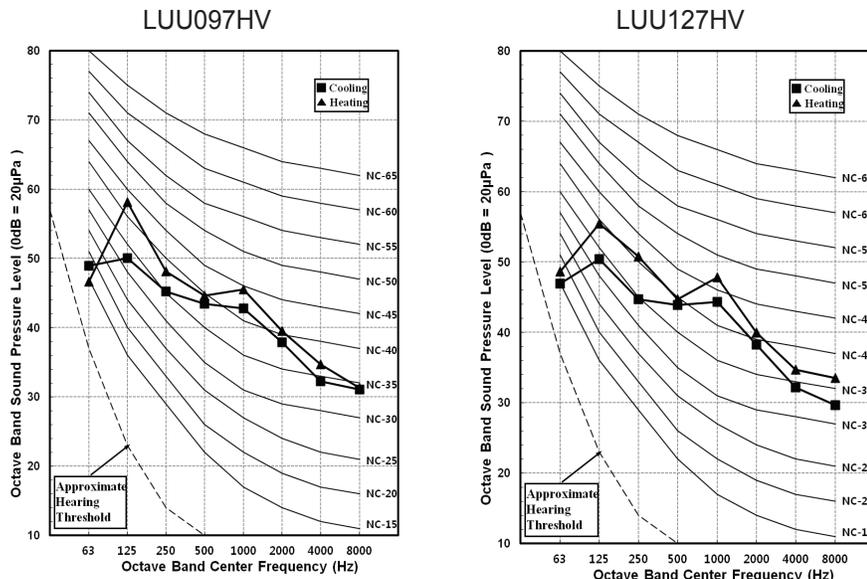

# ACOUSTIC DATA

## Sound Pressure for Outdoor Units

### Outdoor Unit Sound Pressure Diagrams

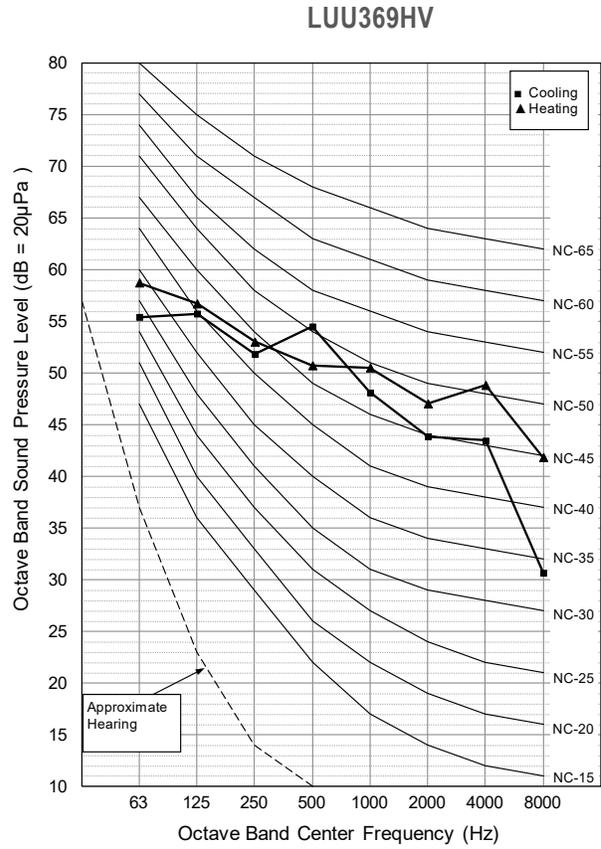
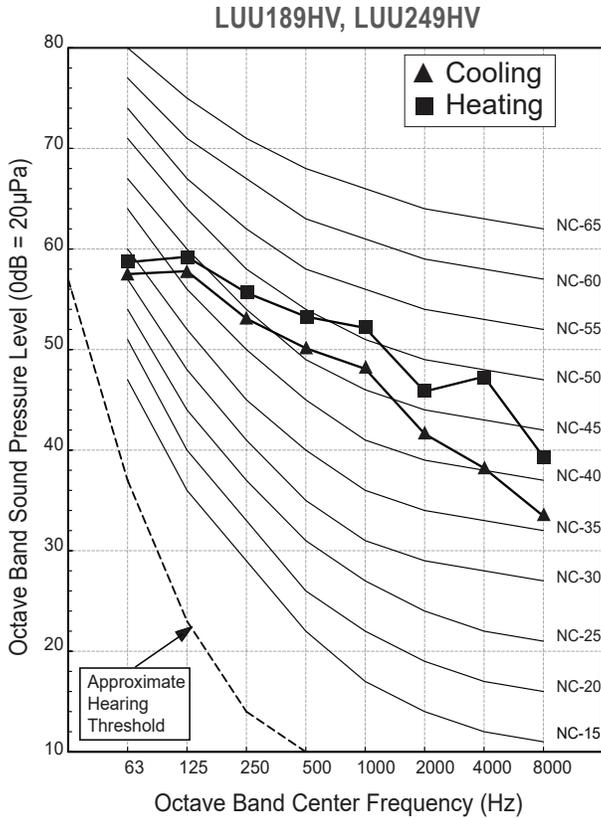

# ACOUSTIC DATA

## Sound Pressure for Indoor Units

### Indoor Unit Sound Pressure Measurement

Figure 13: Indoor Unit Sound Pressure Level Measurement Location.

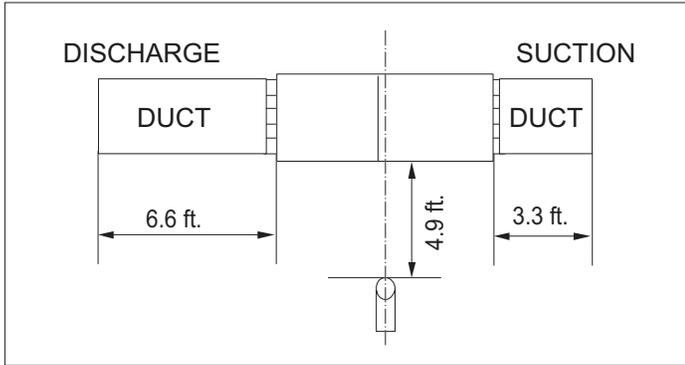

- Measurements taken with no attenuation and units operating at full load normal operating condition.
- Sound level will vary depending on a range of factors such as construction (acoustic absorption coefficient) of particular area in which the equipment is installed.
- Sound power levels are measured in dB(A)±1.
- Tested in anechoic chamber per ISO Standard 3745.

Table 8: Ducted Indoor Unit Sound Pressure Levels (dB[A]).

Model	Sound Pressure Levels (dB[A])		
	H	M	L
<i>Low Static</i>			
LDN097HV4	30	26	23
LDN127HV4	31	28	27
LDN187HV4	36	34	31
<i>High Static</i>			
LHN248HV	37	35	34
LHN368HV	44	42	40

### Indoor Unit Sound Pressure Diagrams

Figure 14: Ducted Indoor Unit Sound Pressure Level Diagrams.

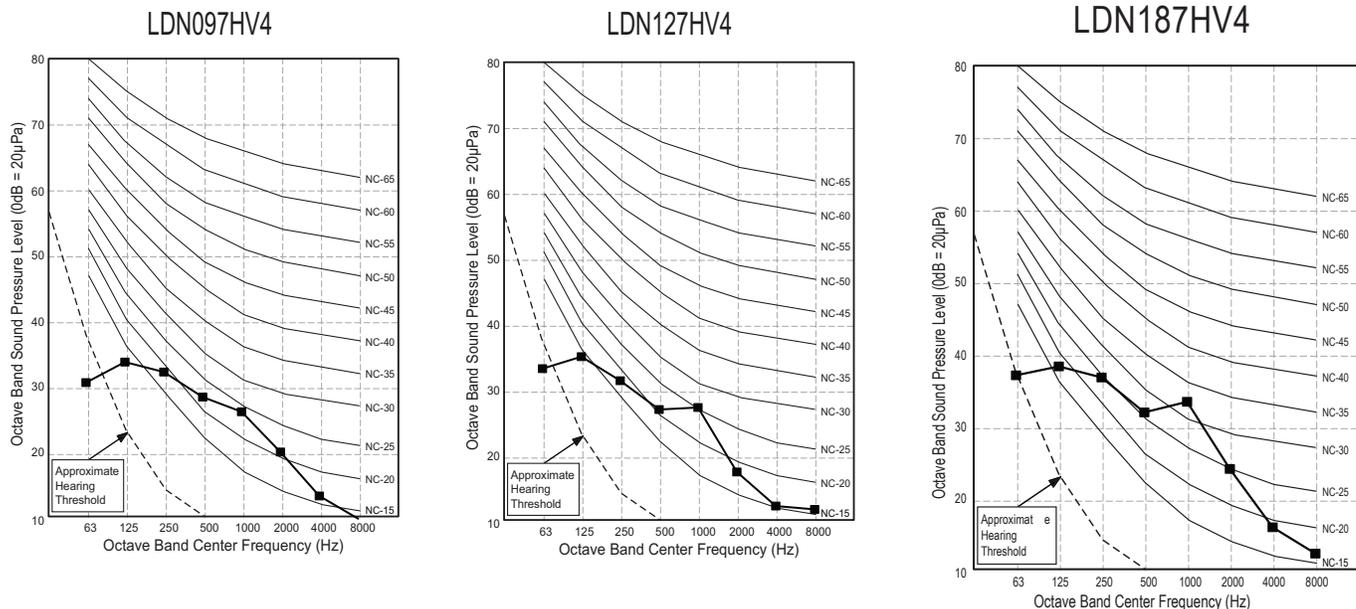

# ACOUSTIC DATA

## Sound Pressure for Indoor Units

### Indoor Unit Sound Pressure Diagrams

Figure 15: Ducted Indoor Unit Sound Pressure Level Diagrams.

LHN248HV

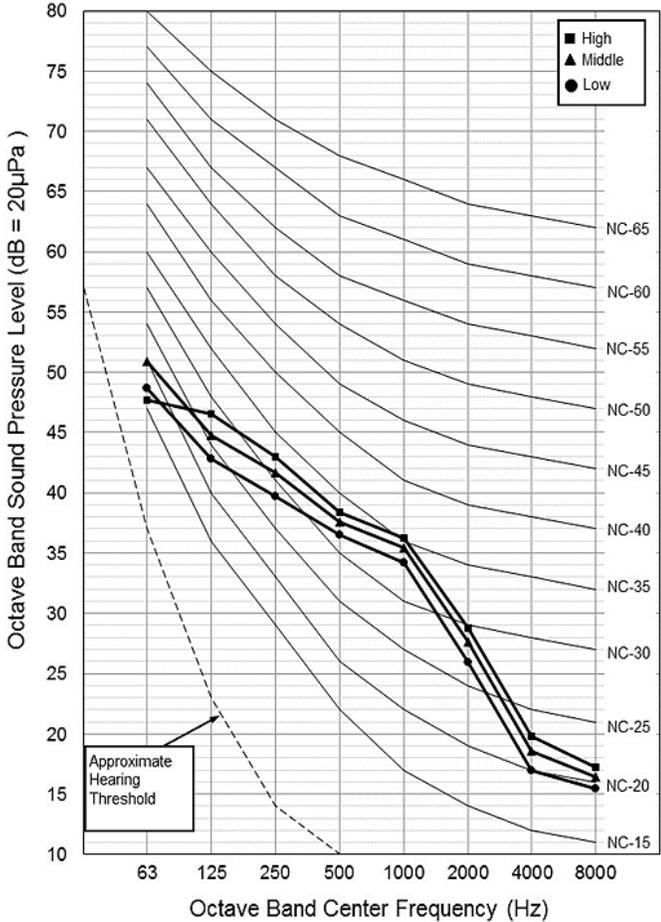

LHN368HV

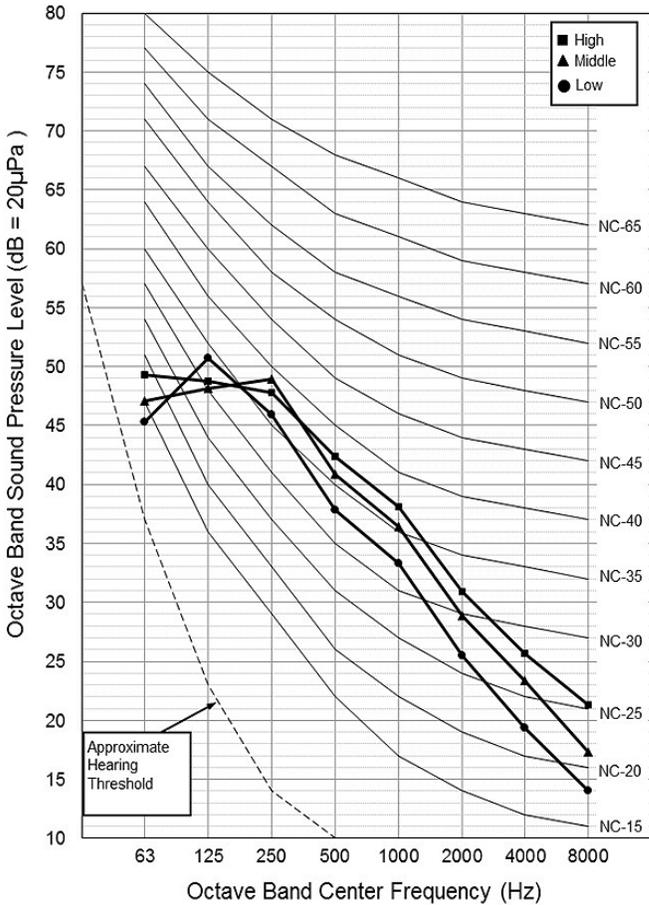

Product Data

# OUTDOOR UNIT REFRIGERANT FLOW DIAGRAM

## Refrigerant Flow Diagram for LUU097HV, LUU127HV

Figure 16: LUU097HV and LUU127HV Ceiling-Concealed Ducted (Low Static) Outdoor Unit Refrigerant Flow Diagram.

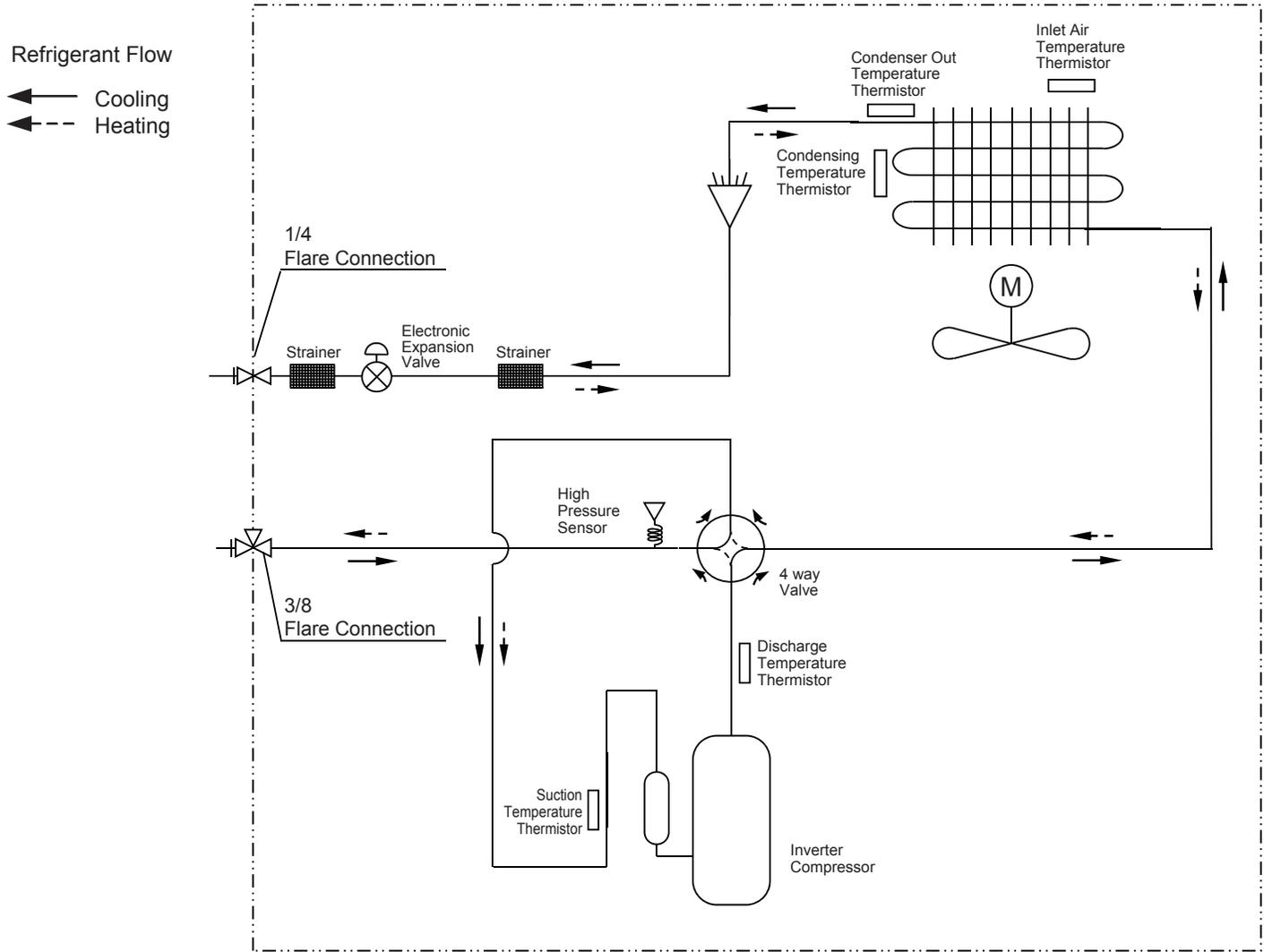

Table 9: LUU097HV and LUU127HV Ceiling-Concealed Ducted (Low Static) Outdoor Unit Thermistor Details.

Description	PCB Connector
Condenser Inlet Temperature Thermistor	CN-AIR
Condenser Outlet Temperature Thermistor	CN-C_PIPE
Discharge Temperature Thermistor	CN-DISCHARGE
Suction Temperature Thermistor	CN-SUCTION
Condensing Temperature Thermistor	CN-MID
High Pressure Sensor	CN-H_PRESSURE
Electronic Expansion Valve	CN-EEV_A

# OUTDOOR UNIT REFRIGERANT FLOW DIAGRAM

## Refrigerant Flow Diagram for LUU189HV, LUU249HV, LUU369HV

Figure 17: LUU189HV, LUU249HV, LUU369HV Refrigerant Flow Diagrams.

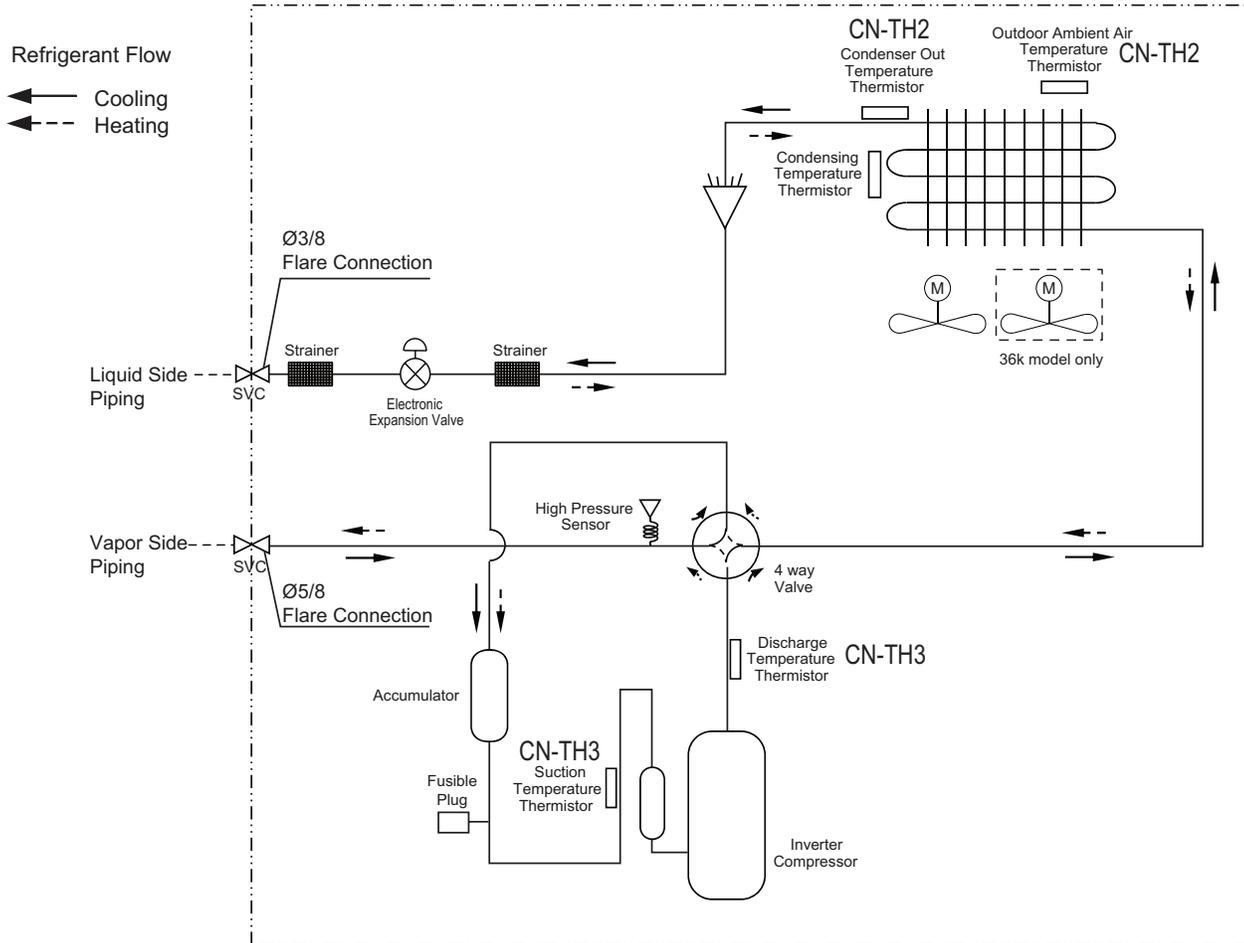

Table 10: LUU189HV, LUU249HV, LUU369HV Ceiling-Concealed Ducted (Low Static) Outdoor Unit Thermistor Details.

Description (Based on Cooling Mode)	PCB Connector	
Suction Temperature Thermistor	CN-TH3	CN-TH3
Discharge Temperature Thermistor		
Condenser Outlet Temperature Thermistor	CN-TH2	CN-TH2
Outdoor Ambient Air Temperature Thermistor		
Condenser Inlet Temperature Thermistor	CN-TH4	CN-TH4

# INDOOR UNIT REFRIGERANT FLOW DIAGRAM

## Refrigerant Flow Diagram for LDN097HV4

Figure 18: LDN097HV4 Ceiling-Concealed Ducted (Low Static) Refrigerant Flow Diagram.

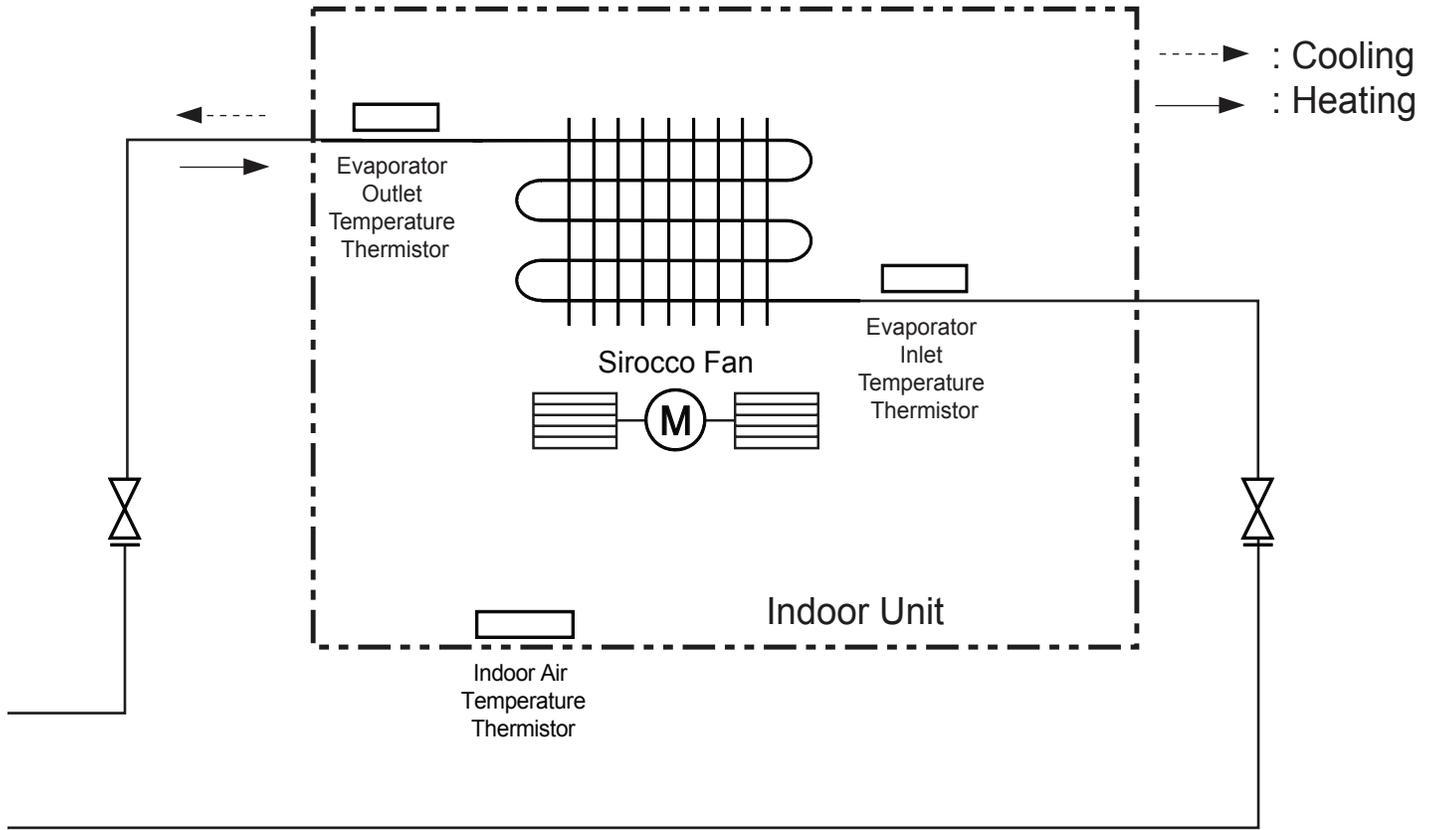

Table 11: LDN097HV4 Ceiling-Concealed Ducted (Low Static) Indoor Unit Thermistor Details.

Description (Based on Cooling Mode)	PCB Connector
Indoor Air Temperature Thermistor	CN-ROOM
Evaporator Inlet Temperature Thermistor	CN-PIPE/IN
Evaporator Outlet Temperature Thermistor	CN-PIPE/OUT

Table 12: LDN097HV4 Ceiling-Concealed Ducted (Low Static) Indoor Unit Refrigerant Pipe Connection Port Diameters.

Model No.	Vapor (inch)	Liquid (inch)
LDN097HV4	3/8	1/4

Table 13: LDN097HV4 Ceiling-Concealed Ducted (Low Static) Indoor Unit Refrigerant Pipe Connections.

Model No.	Vapor (inch)	Liquid (inch)
LDN097HV4	3/8	1/4

# INDOOR UNIT REFRIGERANT FLOW DIAGRAM

## Refrigerant Flow Diagram for LDN127HV4

Figure 19: LDN127HV4 Ceiling-Concealed Ducted (Low Static) Indoor Unit Refrigerant Flow Diagram.

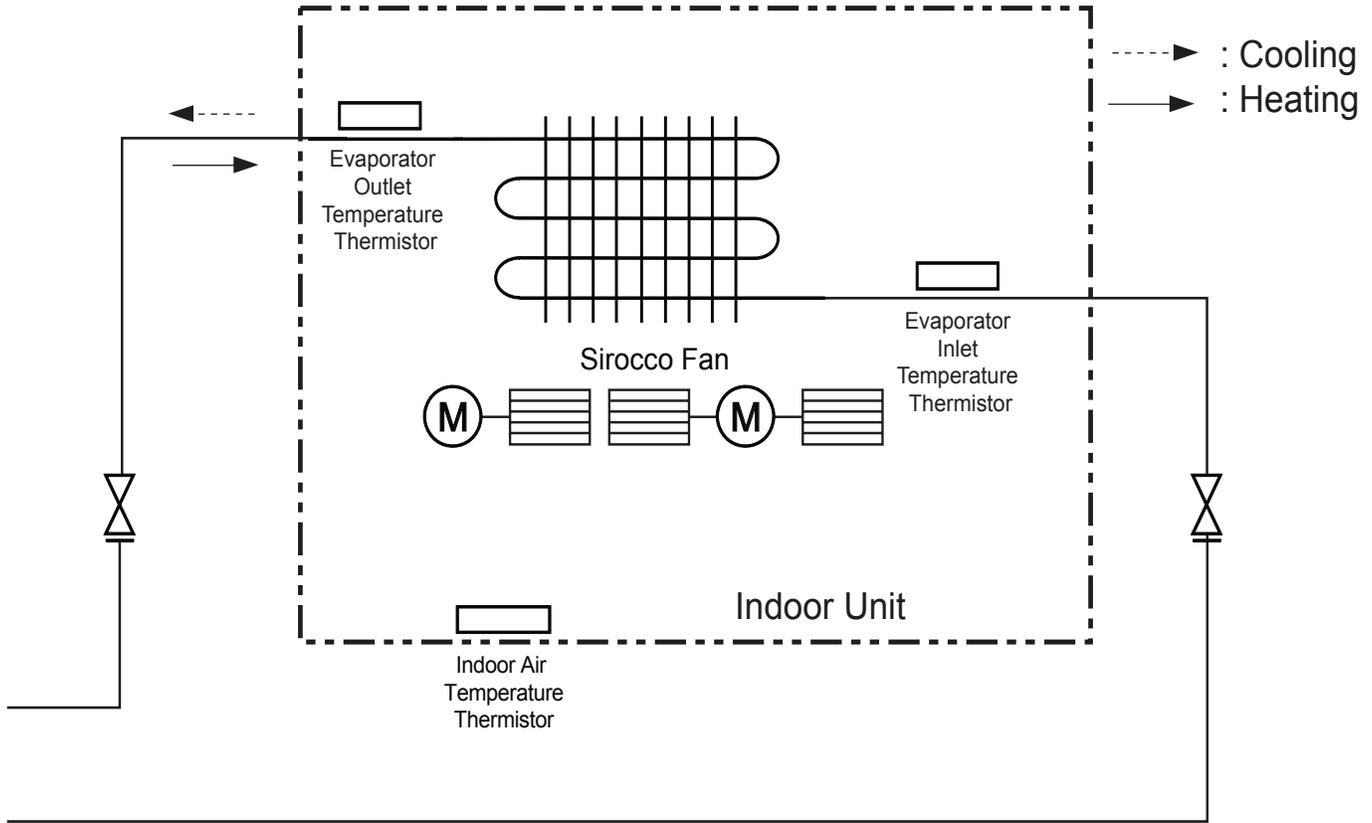

Table 15: LDN127HV4 Ceiling-Concealed Ducted (Low Static) Indoor Unit Thermistor Details.

Description (Based on Cooling Mode)	PCB Connector
Indoor Air Temperature Thermistor	CN-ROOM
Evaporator Inlet Temperature Thermistor	CN-PIPE/IN
Evaporator Outlet Temperature Thermistor	CN-PIPE/OUT

Table 14: LDN127HV4 Ceiling-Concealed Ducted (Low Static) Indoor Unit Refrigerant Pipe Connection Port Diameters.

Model No.	Vapor (inch)	Liquid (inch)
LDN127HV4	3/8	1/4

Table 16: LDN127HV4 Ceiling-Concealed Ducted (Low Static) Indoor Unit Refrigerant Pipe Connections.

Model No.	Vapor (inch)	Liquid (inch)
LDN127HV4	3/8	1/4

# INDOOR UNIT REFRIGERANT FLOW DIAGRAM

## Refrigerant Flow Diagram for LDN187HV4

Figure 20: LDN187HV4 Ceiling-Concealed Ducted Refrigerant Flow Diagram.

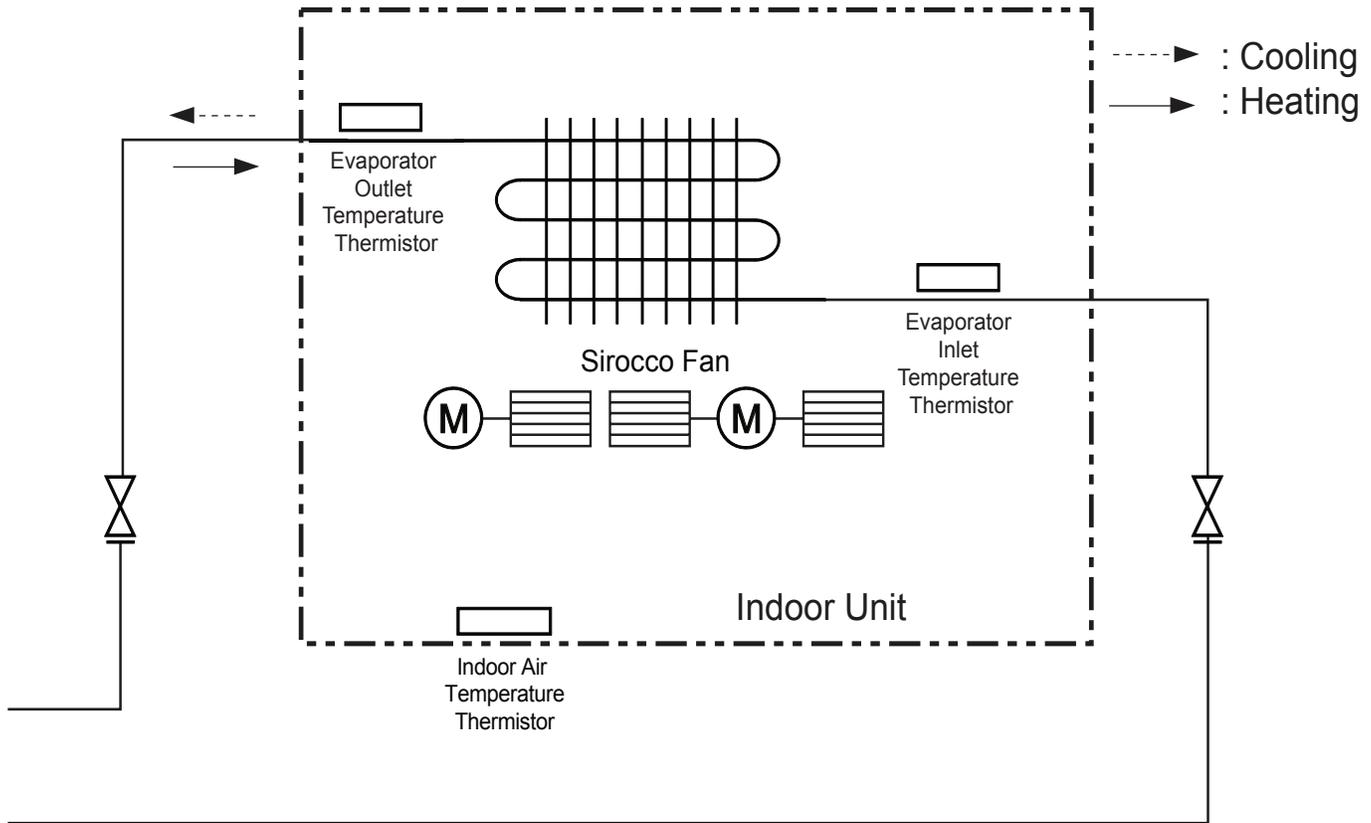

Table 17: LDN187HV4 Ceiling-Concealed Ducted (Low Static) Indoor Unit Thermistor Details.

Description (Based on Cooling Mode)	PCB Connector
Indoor Air Temperature Thermistor	CN-ROOM
Evaporator Inlet Temperature Thermistor	CN-PIPE/IN
Evaporator Outlet Temperature Thermistor	CN-PIPE/OUT

Table 18: LDN187HV4 Ceiling-Concealed Ducted (Low Static) Indoor Unit Refrigerant Pipe Connection Port Diameters.

Model No.	Vapor (inch)	Liquid (inch)
LDN187HV4	Ø1/2	Ø1/4

Table 19: LDN187HV4 Ceiling-Concealed Ducted (Low Static) Indoor Unit Refrigerant Pipe Sizes.

Model No.	Vapor (inch)	Liquid (inch)
LDN187HV4	5/8	3/8

Table 20: LDN187HV4 Ceiling-Concealed Duct (Low Static) Indoor Unit Refrigerant Pipe Connections.

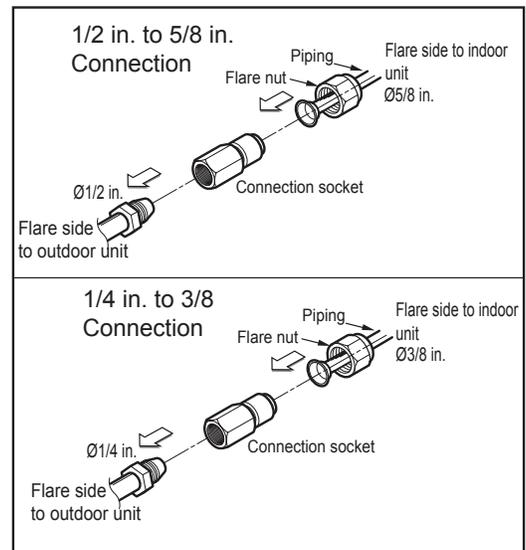

# INDOOR UNIT REFRIGERANT FLOW DIAGRAM

## Refrigerant Flow Diagram for LHN248HV

Figure 21: LHN248HV Ceiling-Concealed Ducted (High Static) Indoor Unit Refrigerant Flow Diagram.

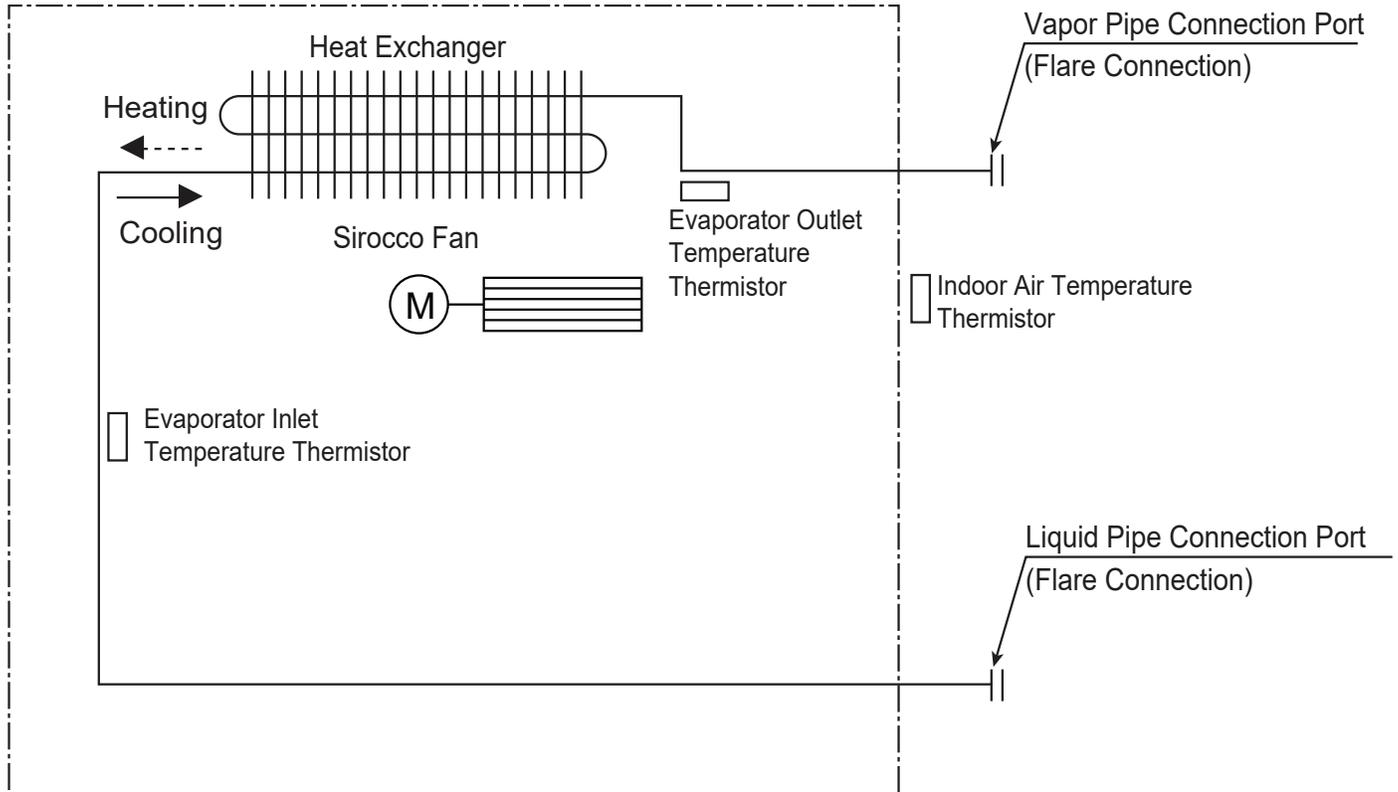

Product Data

Table 21: LHN248HV Ceiling-Concealed Ducted (High Static) Indoor Unit Thermistor Details.

Description (Based on Cooling Mode)	PCB Connector
Indoor Air Temperature Thermistor	CN-ROOM
Evaporator Inlet Temperature Thermistor	CN-PIPE / IN
Evaporator Outlet Temperature Thermistor	CN-PIPE / OUT

Table 22: LHN248HV Ceiling-Concealed Ducted (High Static) Indoor Unit Refrigerant Pipe Connection Port Diameters.

Model No.	Vapor (inch)	Liquid (inch)
LHN248HV	5/8	3/8

Table 23: LHN248HV Ceiling-Concealed Ducted (High Static) Indoor Unit Refrigerant Pipe Sizes.

Model No.	Vapor (inch)	Liquid (inch)
LHN248HV	5/8	3/8

# INDOOR UNIT REFRIGERANT FLOW DIAGRAM

## Refrigerant Flow Diagram for LHN368HV

Figure 22: LHN368HV Ceiling-Concealed Ducted (High Static) Indoor Unit Refrigerant Flow Diagram.

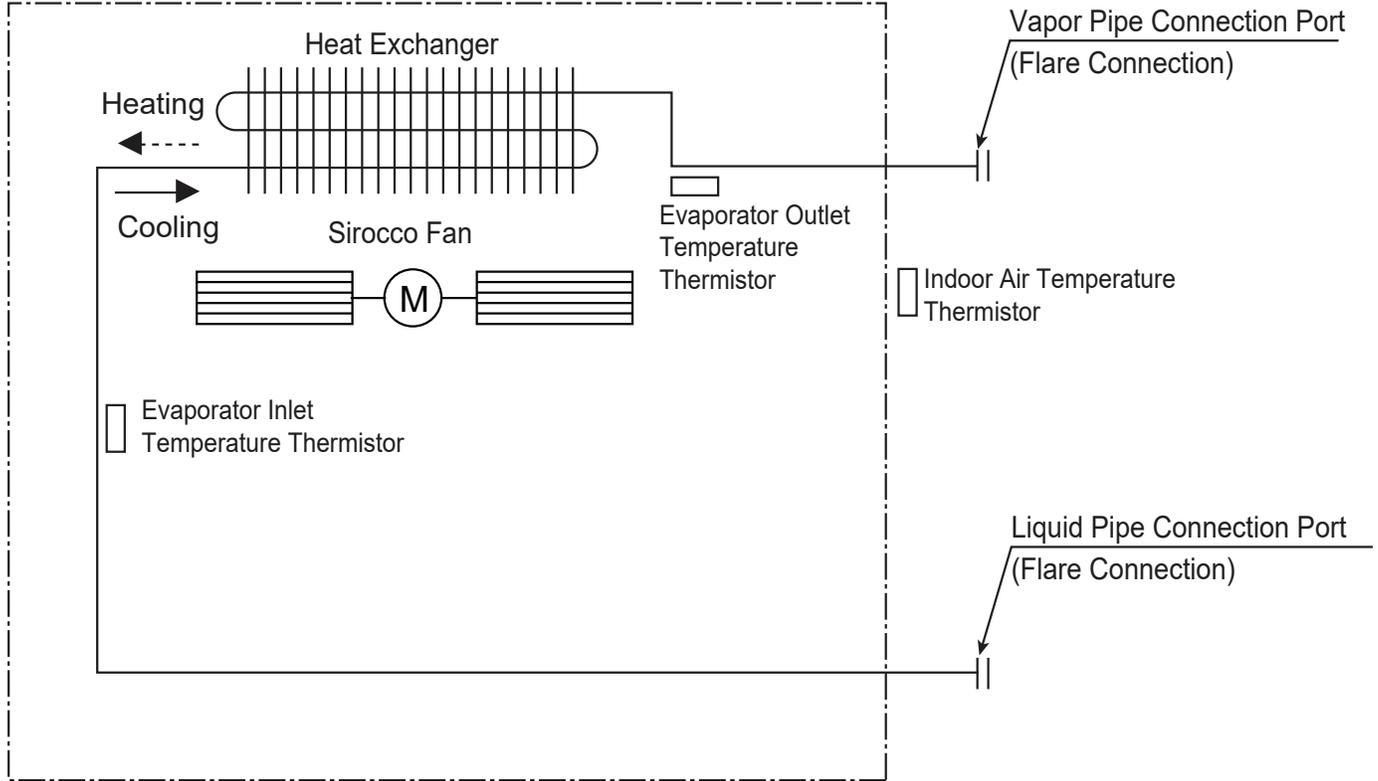

Table 24: LHN368HV Ceiling-Concealed Ducted (High Static) Indoor Unit Thermistor Details.

Description (Based on Cooling Mode)	PCB Connector
Indoor Air Temperature Thermistor	CN-ROOM
Evaporator Inlet Temperature Thermistor	CN-PIPE / IN
Evaporator Outlet Temperature Thermistor	CN-PIPE / OUT

Table 25: LHN368HV Ceiling-Concealed Ducted (High Static) Indoor Unit Refrigerant Pipe Connection Port Diameters.

Model No.	Vapor (inch)	Liquid (inch)
LHN368HV	5/8	3/8

Table 26: LHN368HV Ceiling-Concealed Ducted (High Static) Indoor Unit Refrigerant Pipe Sizes.

Model No.	Vapor (inch)	Liquid (inch)
LHN368HV	5/8	3/8

# OUTDOOR UNIT WIRING DIAGRAM

## Wiring Diagram for LUU097HV, LUU127HV

Figure 23: LUU097HV and LUU127HV Ceiling-Concealed (Low Static) Ducted Outdoor Unit Wiring Diagram.

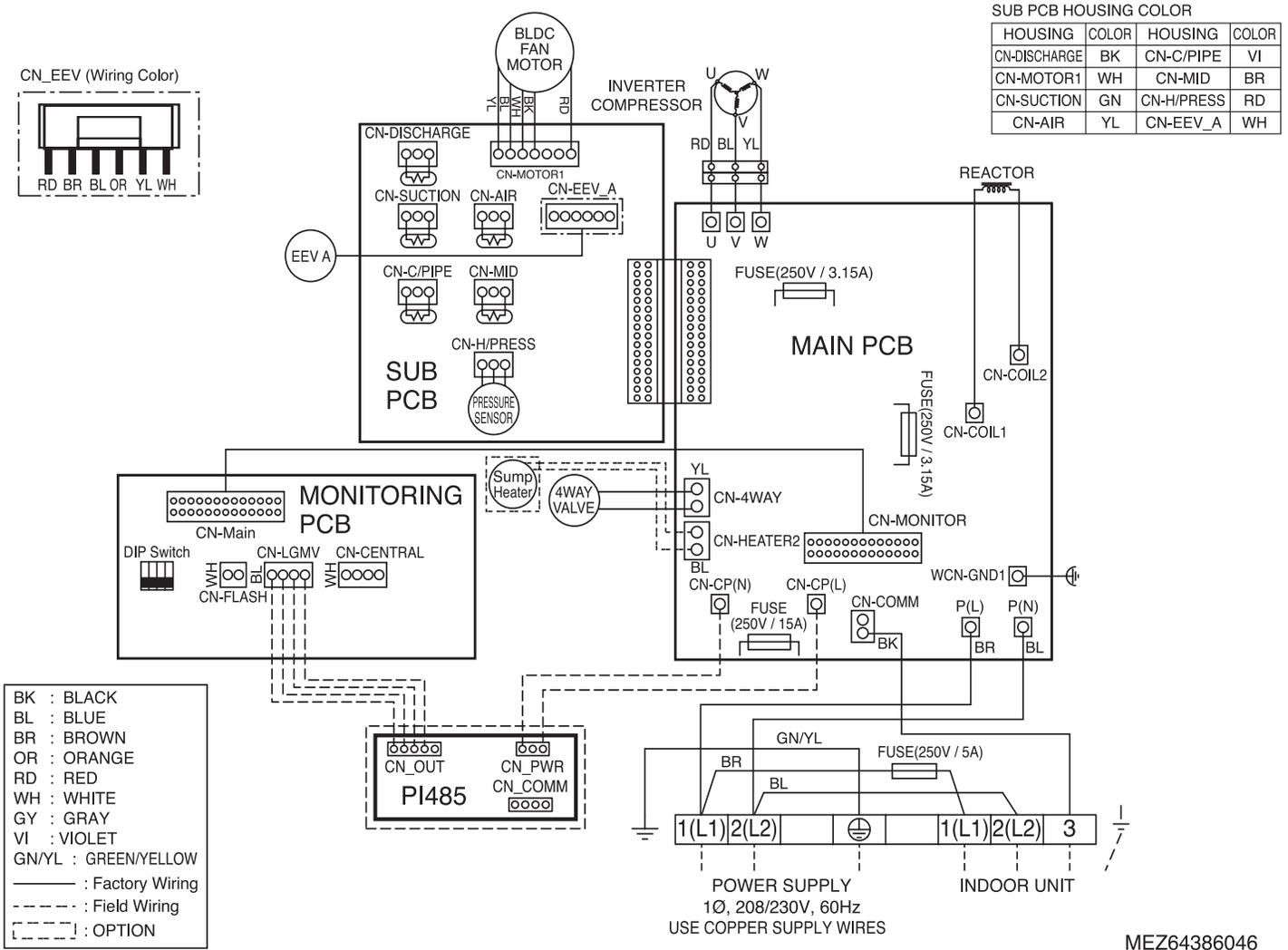

# OUTDOOR UNIT WIRING DIAGRAM

## Wiring Diagram for LUU189HV

Figure 24: LUU189HV Outdoor Unit Wiring Diagram.

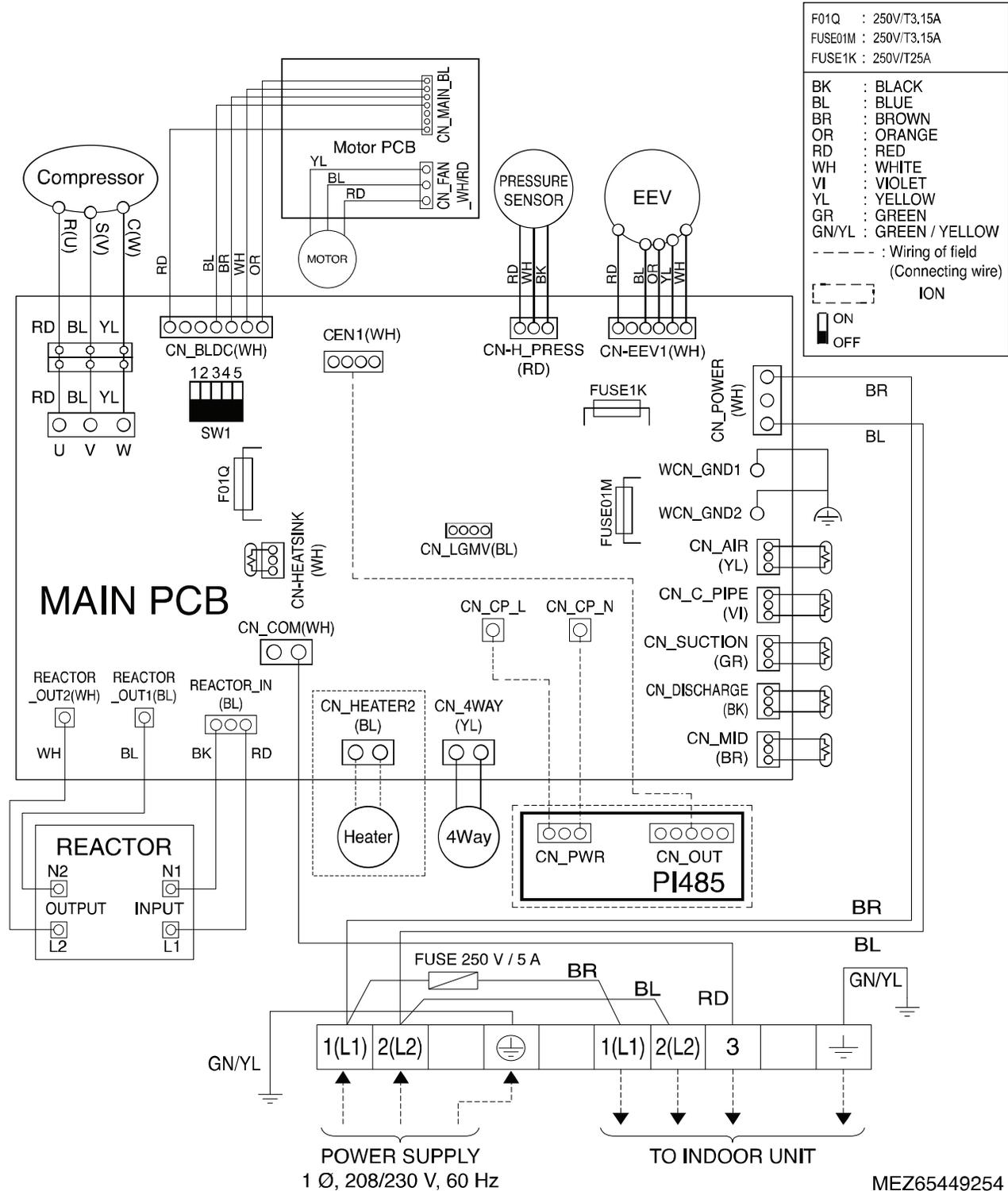

MEZ65449254

7.19

# OUTDOOR UNIT WIRING DIAGRAM

## Wiring Diagram for LUU249HV

Figure 25: LUU249HV Outdoor Unit Wiring Diagram.

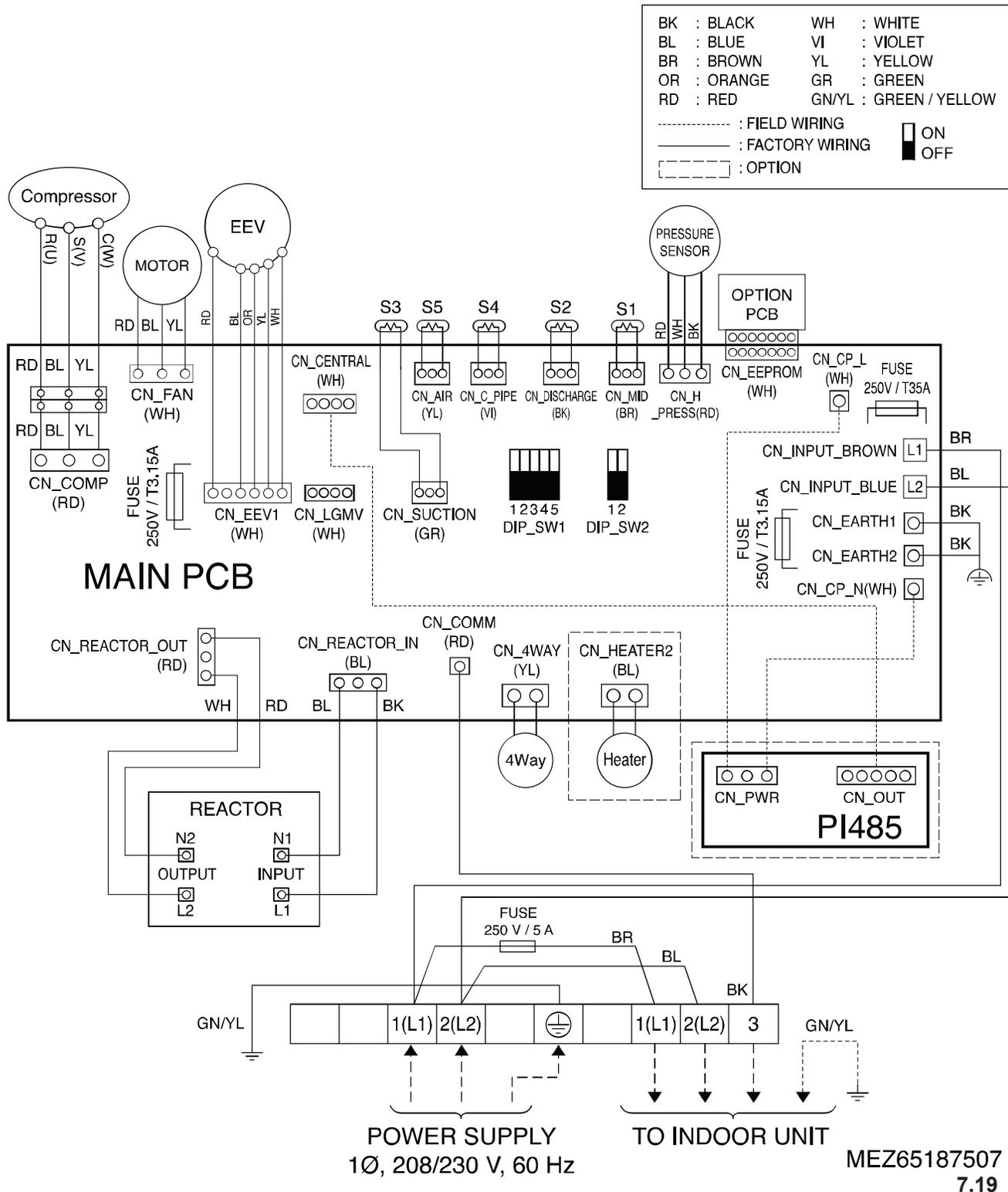

Product Data

# OUTDOOR UNIT WIRING DIAGRAM

## Wiring Diagram for LUU369HV

Figure 26: LUU369HV Outdoor Unit Wiring Diagram.

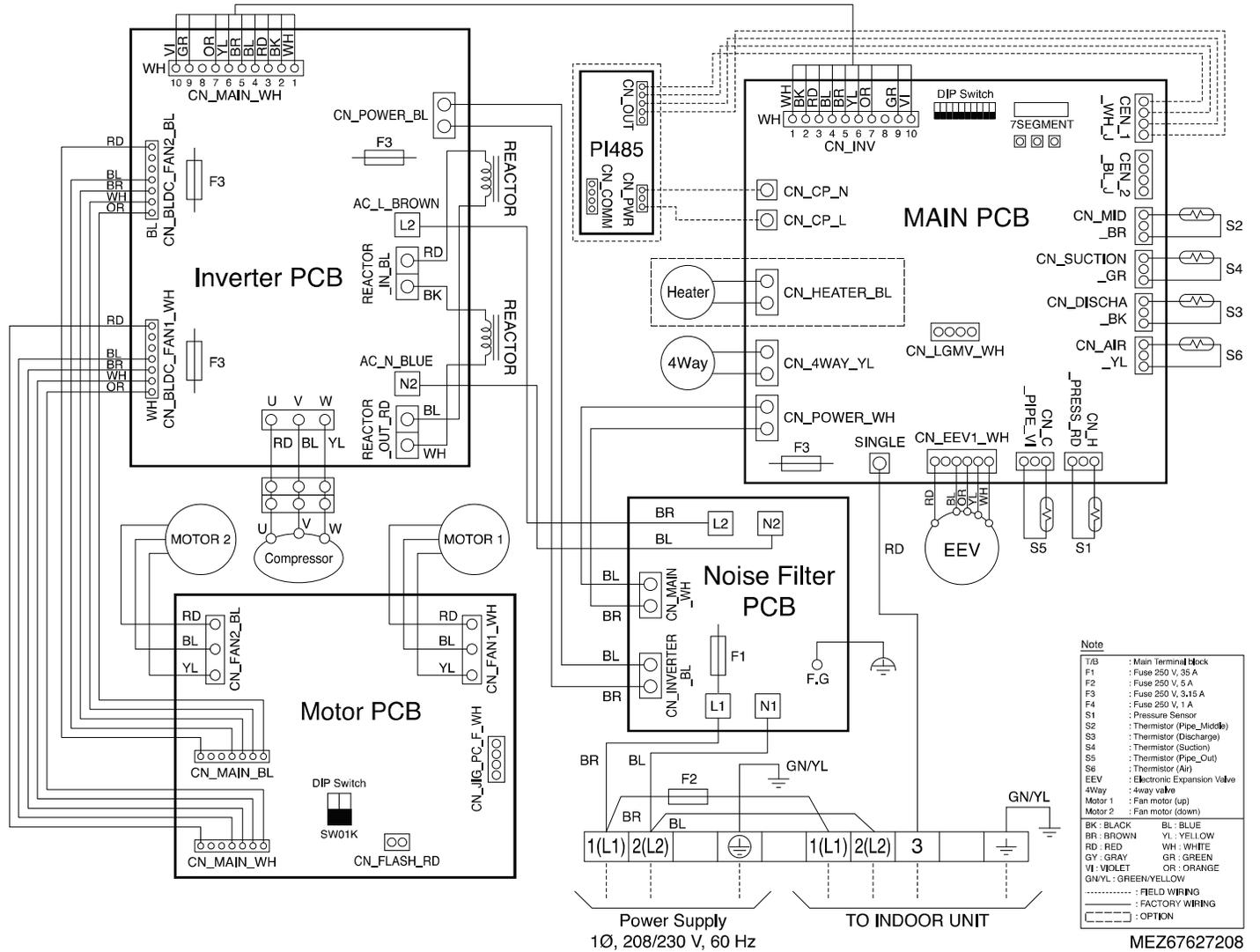

**Note**

T/B	: Main Terminal Block
F1	: Fuse 250 V, 35 A
F2	: Fuse 250 V, 5 A
F3	: Fuse 250 V, 3,15 A
F4	: Fuse 250 V, 1 A
S1	: Pressure Sensor
S2	: Thermistor (Pipe_Middle)
S3	: Thermistor (Discharge)
S4	: Thermistor (Suction)
S5	: Thermistor (Pipe_Out)
S6	: Thermistor (Air)
EEV	: Electronic Expansion Valve
4Way	: 4-way valve
Motor 1	: Fan motor (up)
Motor 2	: Fan motor (down)
BR	: BLACK
BL	: BLUE
BR	: BROWN
RD	: RED
WH	: WHITE
YL	: YELLOW
GY	: GRAY
GR	: GREEN
VI	: VIOLET
OR	: ORANGE
GN/YL	: GREEN/YELLOW
---	: FIELD WIRING
---	: FACTORY WIRING
---	: OPTION

MEZ67627208  
7.19

Single Zone Ceiling-Concealed Ducted System Engineering Manual



# INDOOR UNIT WIRING DIAGRAM

## Wiring Diagram for LDN097HV4

Figure 27: LDN097HV4 Ceiling-Concealed Ducted (Low Static) Indoor Unit Wiring Diagram.

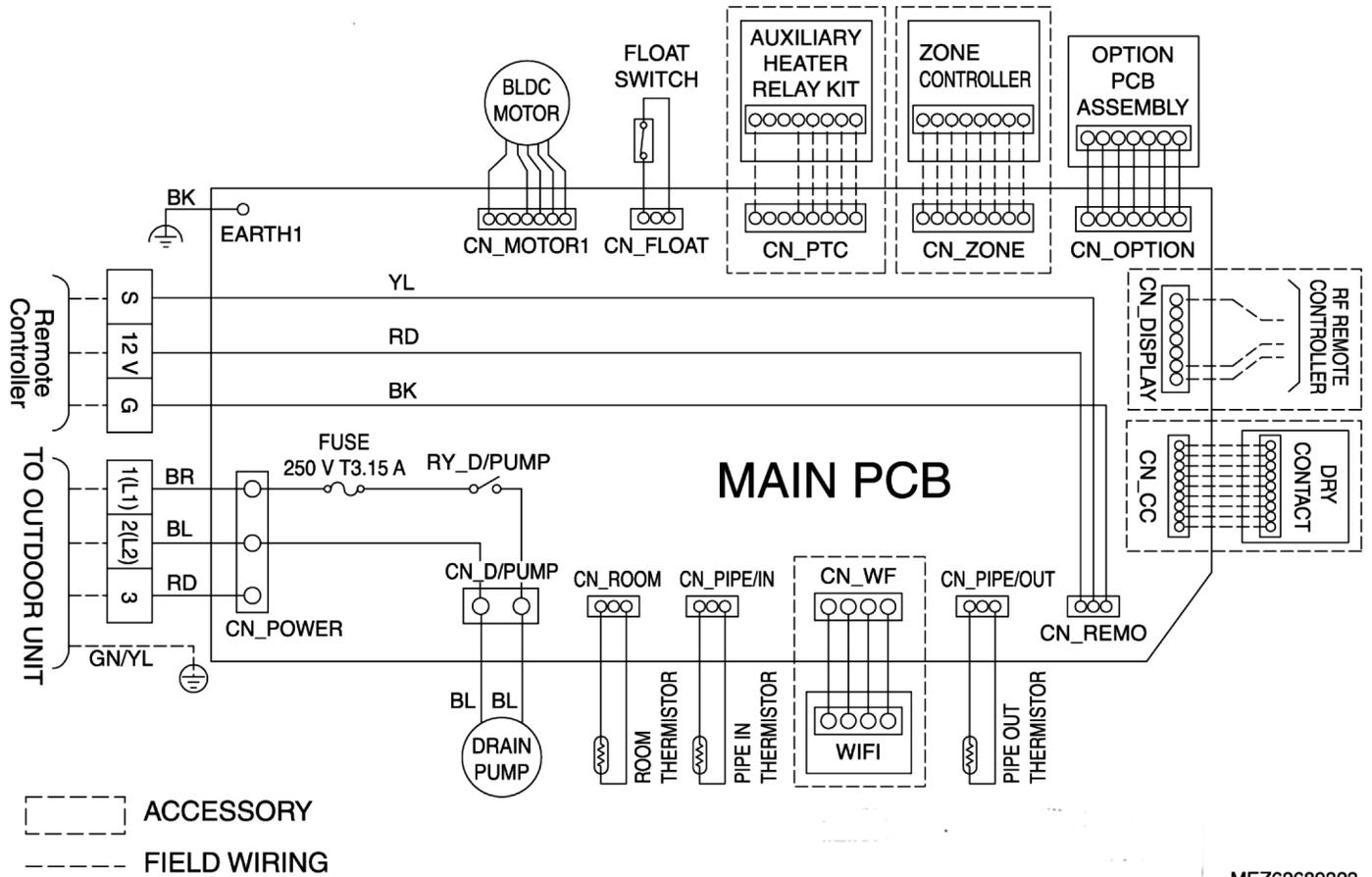

MEZ62689323

8.19.

Product Data

# INDOOR UNIT WIRING DIAGRAM

## Wiring Diagram for LDN127HV4, LDN187HV4

Figure 28: LDN127HV4, LDN187HV4 Ceiling-Concealed Ducted (Low Static) Indoor Unit Wiring Diagram.

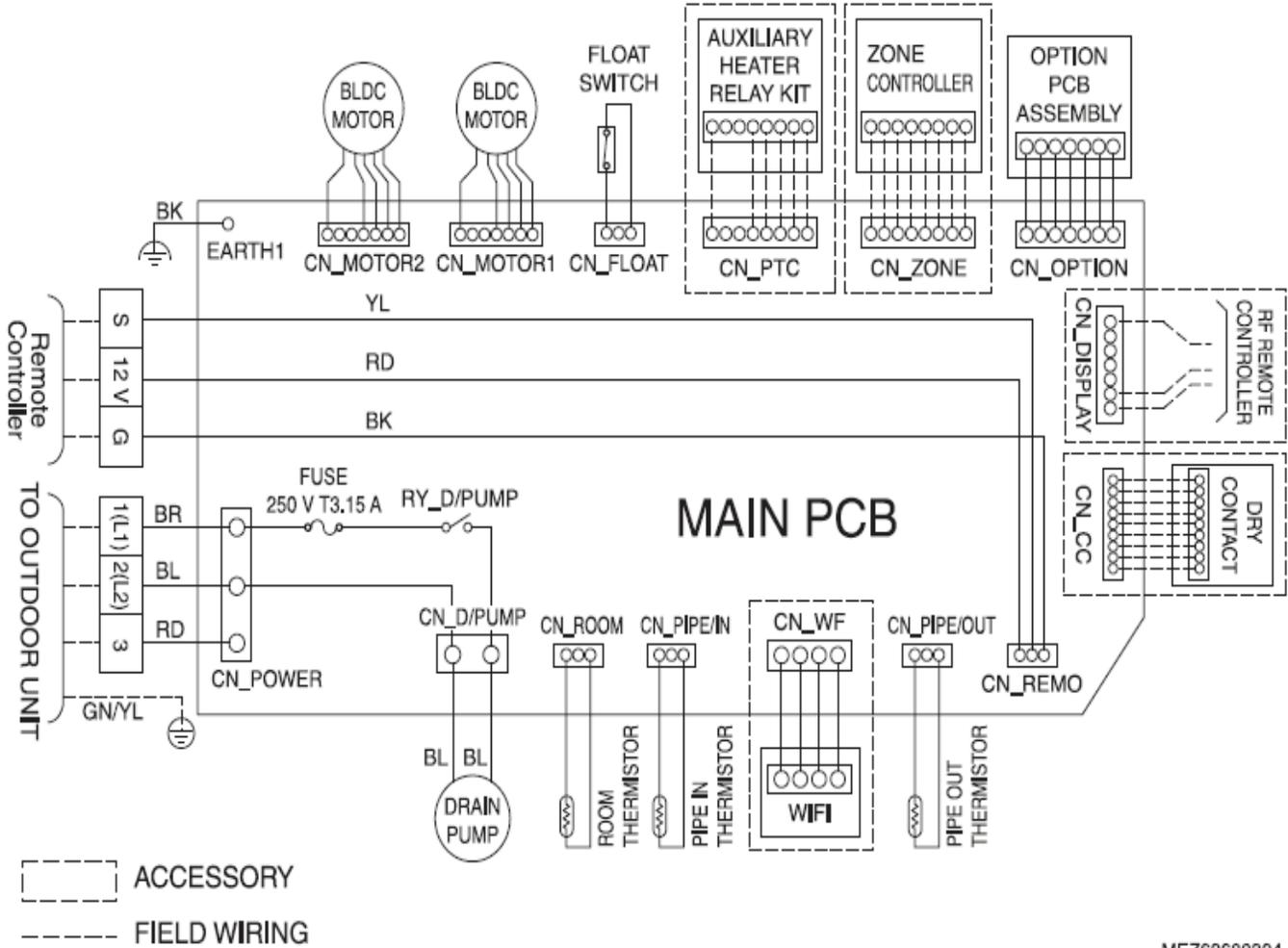

MEZ62689324

# INDOOR UNIT WIRING DIAGRAM

## Wiring Diagram for LHN248HV, LHN368HV

Figure 29: LHN248HV, LHN368HV Ceiling-Concealed Ducted (High Static) Indoor Unit Wiring Diagram.

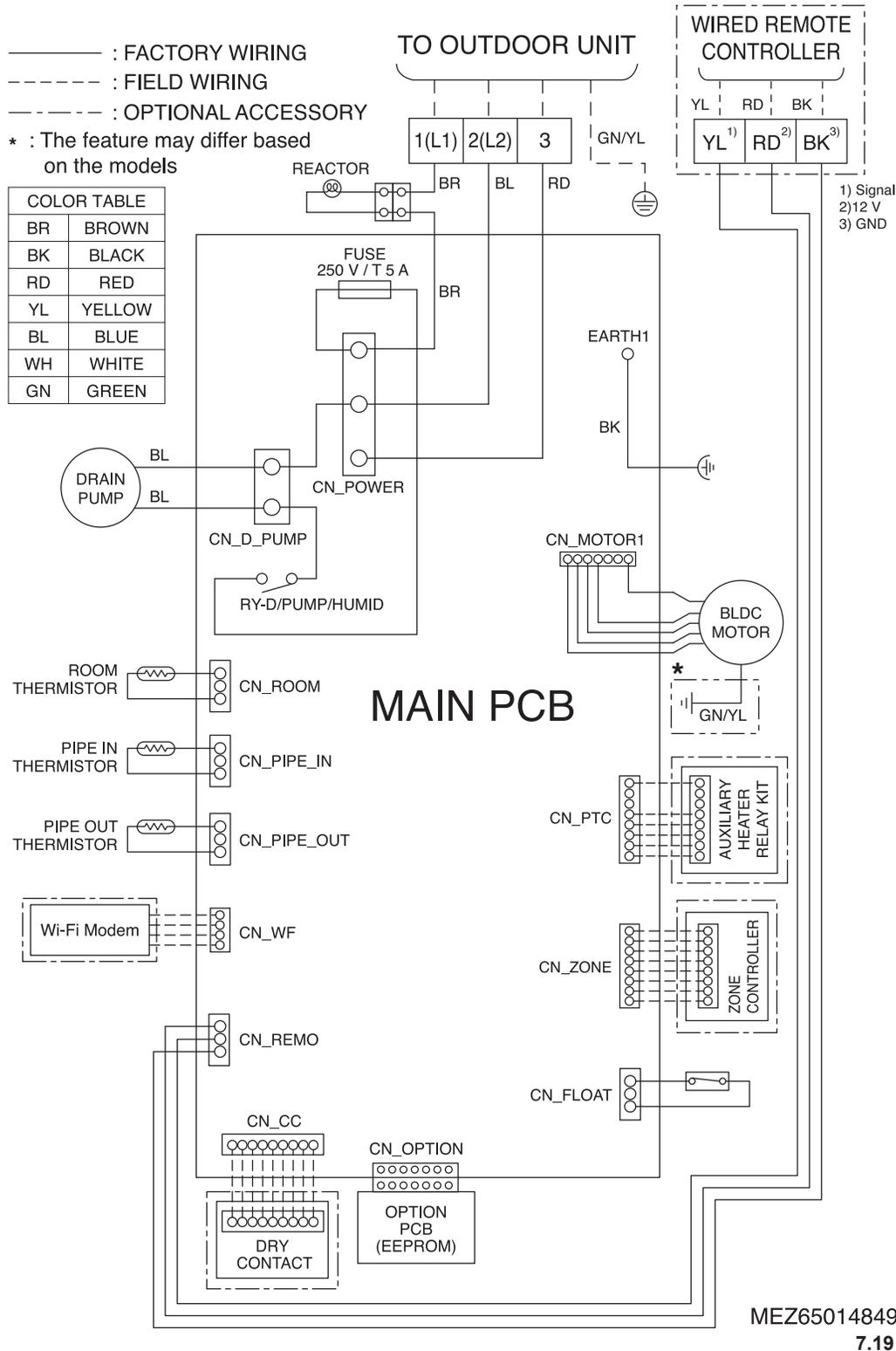

# ELECTRICAL CONNECTIONS

## General Power Wiring / Communications Cable Guidelines

- Follow manufacturer's circuit diagrams displayed on the inside of the control box cover.
- Have a separate power supply for the indoor units.
- Provide a circuit breaker switch between the power source and the indoor unit.
- Confirm power source specifications.
- Properly ground the outdoor unit and the indoor unit per NEC and local codes.
- Connect the wiring firmly so that the wires cannot be easily pulled out.
- Confirm that the electrical capacity is sufficient.
- Power supply to the outdoor unit must be selected based on NEC and local codes. Maximum allowable voltage fluctuation  $\pm 10\%$  or name-plate rated value.
- It is recommended that a circuit breaker is installed, especially if conditions could become wet or moist.
- Include a disconnect in the power wiring system. Add an air gap contact separation of at least 1/8 inch in each active (phase) conductor.
- Any openings where the field wiring enters the cabinet must be completely sealed.

⊘ Do not install power wiring to the outdoor unit and the communication / connection (power) cable to the indoor unit in the same conduit. Use separate conduits.

## Communication / Connection (Power) Cable Specifications from Outdoor Unit to Indoor Unit

- Power wiring to the outdoor unit must be solid or stranded, and must comply with the applicable local and national electric codes.
- For communication / connection (power) wires between the Single Zone outdoor unit and the indoor unit, use a minimum 14 gauge, four (4) conductor, stranded, shielded or unshielded wire. If shielded, the wire must be grounded to the chassis at the outdoor unit only. Wiring must comply with all applicable local and national codes.
- Communication cable from indoor unit to remote controller(s) is to be 22 AWG, 3-conductor, twisted, stranded, unshielded. Wiring must comply with all applicable local and national codes.
- Insulation material as required by local code.
- Firmly attach the cable; provide slack but secure in a way to prevent external forces from being imparted on the terminal block.
- Wiring must be completed without splices.

### WARNING

- Terminal screws may become loose during transport. Properly tighten the terminal connections during installation or risk electric shock, physical injury, or death.
- Loose wiring may cause unit to malfunction, overheat, and catch fire, resulting in severe injury or death.

### Note:

- Terminal screws may loosen during transport. Properly tighten the terminal connections during installation or risk equipment malfunction or property damage.
- Loose wiring may cause unit malfunction, the wires to burnout or the terminal to overheat and catch fire. There is a risk of equipment malfunction or property damage.

A voltage drop may cause the following problems:

- Magnetic switch vibration, fuse breaks, or disturbance to the normal function of an overload protection device.
- Compressor will not receive the proper starting current.

# ELECTRICAL CONNECTIONS

## Note:

- Always verify the communication cable is connected to a communications terminal on the Single Zone unit. Ⓣ Never apply line voltage power to the communication cable connection. If contact is made, the PCBs will be damaged.
- The shield of the communications cable connecting the outdoor unit to the indoor unit must be grounded only to the outdoor unit frame.
- Tie the shield of each cable segment together using a wire nut at the indoor unit. Maintain polarity throughout the communication network.
- Position the incoming power to the outdoor unit away from the power / communications cables from the outdoor unit to the indoor unit.
- Ⓣ Never use a common multiple-core communications cable.

Figure 30: Typical Single Zone Outdoor Unit to Indoor Unit Wiring and Communications Cable Diagram.

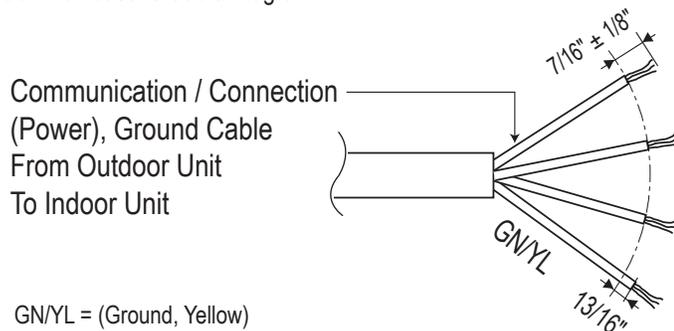

## ⚠ WARNING

All power wiring and communication cable installation must be performed by trained service providers working in accordance with local, state, and National Electrical Code (NEC) / UL / ETL federal regulations related to electrical equipment and wiring, and following the manufacturer product diagrams, requirements, and instructions in this manual. Failure to do so will lead to electric shock which can cause physical injury or death.

## Note:

- Use of 14 gauge, four (4) conductor, stranded, shielded or unshielded wire is allowed for lengths up to the published maximum pipe length, plus recommended slack at both ends.

# ELECTRICAL CONNECTIONS

## Outdoor Unit Power Wiring / Communications Cable Connections

### LUU097HV, LUU127HV, LUU189HV, LUU249HV, LUU369HV Outdoor Unit Connections

1. Remove the cover or control cover from the unit by loosening the fastening screws.
2. Take off the caps on the conduit panel.
3. Connect both the power supply and low voltage lines to the corresponding terminals on the terminal block.
4. Be sure to ground the unit by following local codes.
5. Allow for enough length (add several inches) for each wiring.
6. Secure the cable with the cord clamp.
7. Secure conduit tubes with lock nuts.
8. Reattach the control cover to the original position with the fastening screws.

Figure 31: LUU097HV, LUU127HV ODU Terminal Block Location.

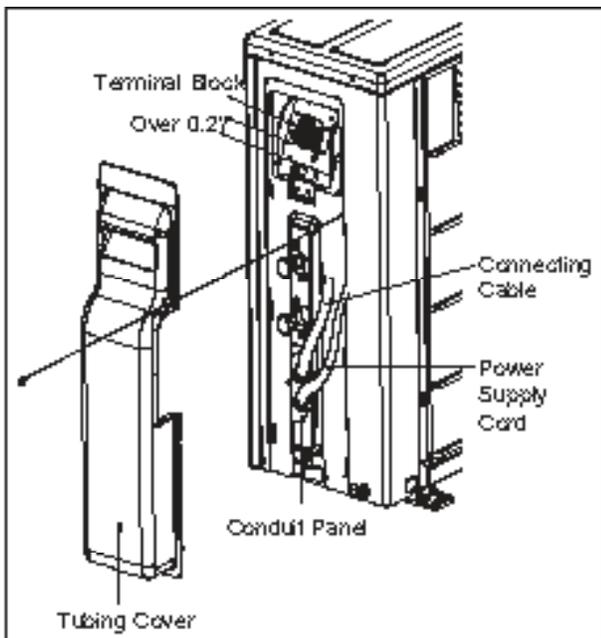

Figure 32: LUU189HV, LUU249HV ODU Terminal Block Location.

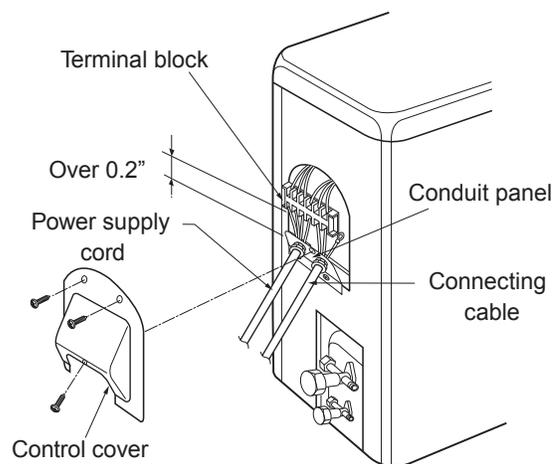
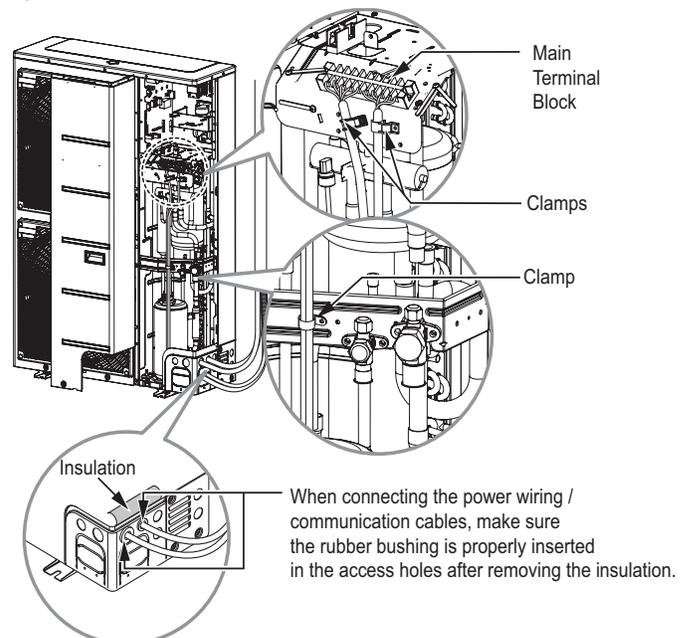

Figure 33: LUU369HV ODU Terminal Block Location.



### LUU369HV Outdoor Unit Connections

1. Remove the side panel.
2. Use the clamp to attach the wiring / cable.

# ELECTRICAL CONNECTIONS

## Ducted Indoor Unit Power Wiring / Communications Cable Connections

- To access the terminal block, first detach the cover from the control box.
- Insert the power wiring / communications cable from the outdoor unit through the sides of the indoor unit and control box. Pass the wiring through the designated access holes to prevent damage. To prevent electromagnetic interference and product malfunction, leave a space between the power wiring and communications cable outside of the indoor unit. (For power wiring / communications cable between the single zone outdoor unit and the indoor unit, use a four-conductor, stranded, shielded or unshielded wire. If shielded, the wire must be grounded to the chassis at the outdoor unit only.)
- Connect each wire to its appropriate terminal on the indoor unit control board. Verify that the color and terminal numbers from the outdoor unit wiring match the color and terminal numbers on the indoor unit.
- Secure the power wiring / communications cable with the cable restraint.
- Reattach the steel clamp to the inside of the control panel.
  - Place the wiring / cables in the clamp and tighten the plastic clamp to an open surface of the control panel.
  - Do not apply force to the wiring connections when clamping.
  - Neatly arrange the wiring. Do not catch the wiring in the electric box cover. Ensure the cover firmly closes.
- Fill in any gaps around the wiring access holes with sealant to prevent foreign particles from entering the indoor unit.

Figure 35: Accessing the Indoor Unit Terminal Block.

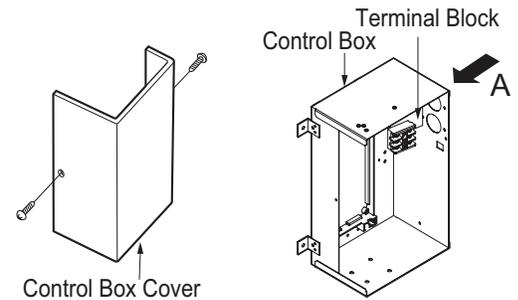

### Using a Conduit

- Remove the rubber stopper on the indoor unit. Pass the power wiring / communications cable through the conduit, the conduit mounting plate, and to / through the control panel of the indoor unit.
- Connect the power wiring / communications cable to the indoor unit terminal block.
- Screw the conduit mounting plate to the indoor unit.
- Tighten the conduit and the conduit mounting plate together.

Figure 36: Ducted Indoor Unit Terminal Block Location / Using a Conduit.

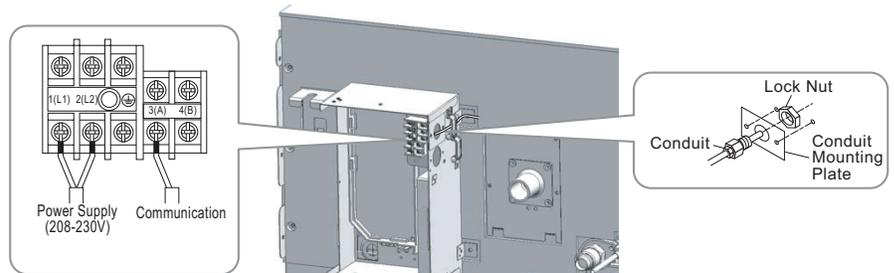

### Note:

Always use a circuit breaker or time delay fuse when connecting electrical wiring to the unit.

### ⚠ WARNING

- Separately wire the high and low voltage lines. There is a risk of electric shock, physical injury, or death.
- Use heat-proof electrical wire capable of withstanding temperatures up to 167°F to avoid wiring malfunction and electrical shock, which may cause physical injury or death.
- Ensure you connect the wire firmly. Loose wiring may cause unit malfunction, the wires to burnout or the terminal to overheat and catch fire. There is a risk of electric shock, physical injury or death.
- Use outdoor and waterproof connection cable rated up to 300V for the connection between the indoor and outdoor unit to avoid electrical shock, which may cause physical injury or death.

### Note:

- Separately wire the high and low voltage lines to avoid damage to unit.
- Use heat-proof electrical wire capable of withstanding temperatures up to 167°F to avoid damage to unit.
- Always use a circuit breaker or time delay fuse when connecting electrical wiring to the unit.
- Connect the wire firmly. Loose wiring may cause unit malfunction, the wires to burnout or the terminal to overheat and catch fire. There is a risk of equipment malfunction or property damage.
- Use outdoor and waterproof connection cable rated up to 300V for the connection between the indoor and outdoor unit to avoid damage to the unit.
- Comply with local codes while running wire from the indoor unit to the outdoor unit.
- Do not allow wire to touch refrigerant tubing, the compressor or any moving parts since it can lead to mechanical failure.

Figure 34: Circuit Breaker/Time Delay Fuse Connection.

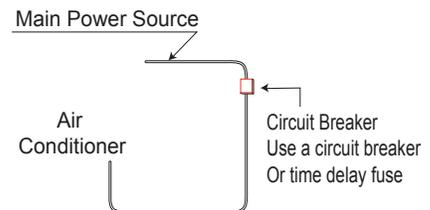

# ELECTRICAL CONNECTIONS

## Wiring Connections

Figure 37: Detailed Power / Communications System Schematic.

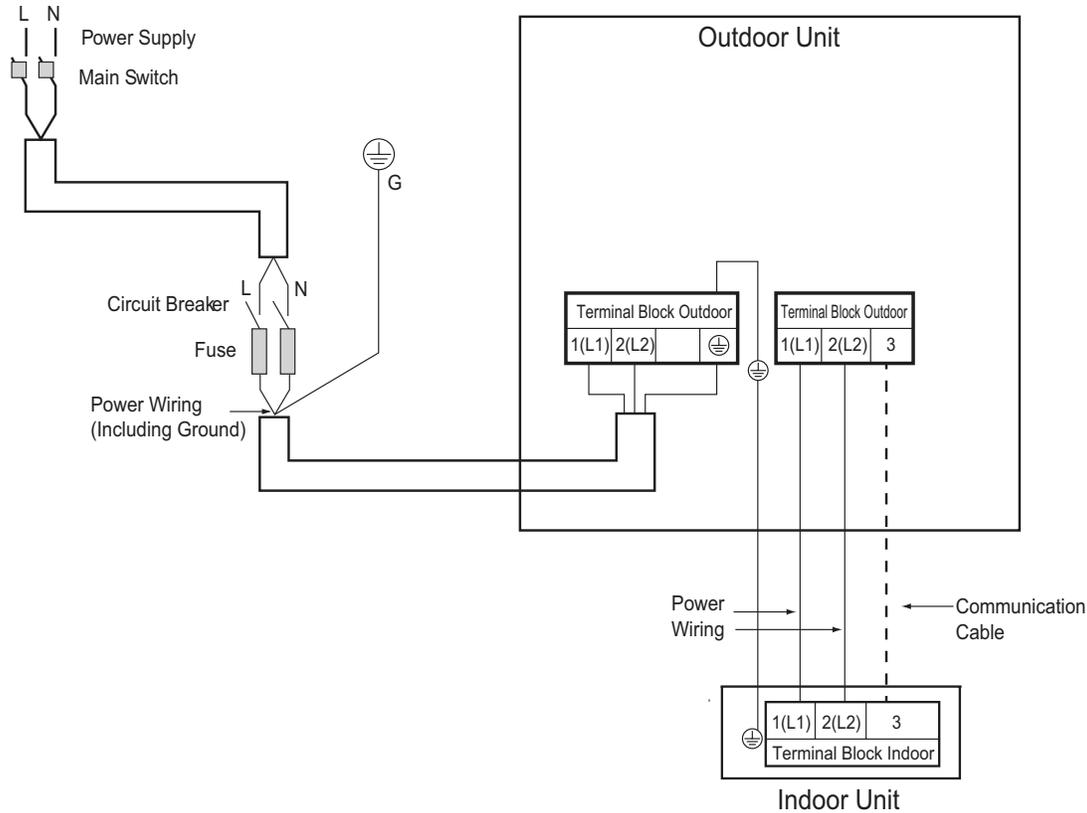

### Note:

- Power wiring and communications cable sizes must comply with applicable federal UL / ETL, state, and local codes.
- Separately wire the high and low voltage lines to avoid damage to the unit.
- Local codes may require field-installed disconnect switches from outdoor unit to indoor unit.
- Use heat-proof electrical wire capable of withstanding temperatures up to 167°F to avoid damage to unit.
- Always use a circuit breaker or time delay fuse when connecting electrical wiring to the unit.
- Firmly connect the wire. Loose wiring may cause unit malfunction, the wires to burnout or the terminal to overheat and catch fire. There is a risk of equipment malfunction or property damage.
- Use outdoor and waterproof connection cable rated up to 300V for the connection between the indoor and outdoor unit to avoid damage to the unit.
- Comply with local codes while running wire from the indoor unit to the outdoor unit.
- ⚠ Do not allow wire to touch refrigerant tubing, the compressor or any moving parts since it can lead to mechanical failure.

# ELECTRICAL CONNECTIONS

## Wired Controller Connections

Optional controllers can connect to the Single Zone Ducted indoor unit in one of two different ways.

1. LG Wired Remote Extension Cable with Molex plug (PZCWRC1; sold separately) that connects to the CN-REMO terminal on the indoor unit PCB.
2. Field-supplied controller cable that connects to the indoor unit terminal block (must be at least UL2547 or UL1007, and at least FT-6 rated if local electric and building codes require plenum cable usage). Communication cable from indoor unit to remote controller(s) is to be 22 AWG, 3-conductor, twisted, stranded, unshielded. Wiring must comply with all applicable local and national codes.

Figure 38: PZCWRC1 LG Wired Remote Extension Cable

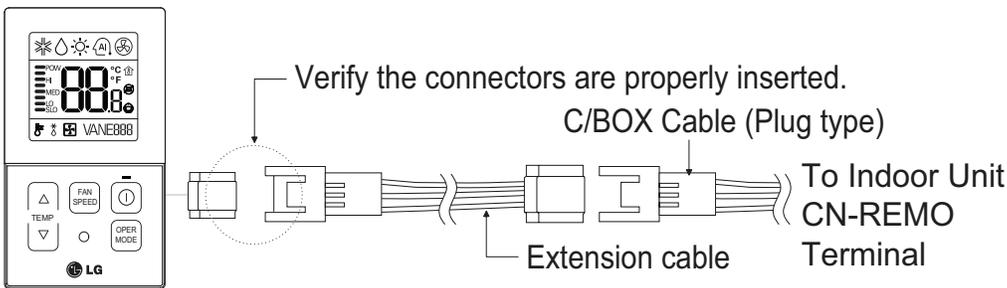
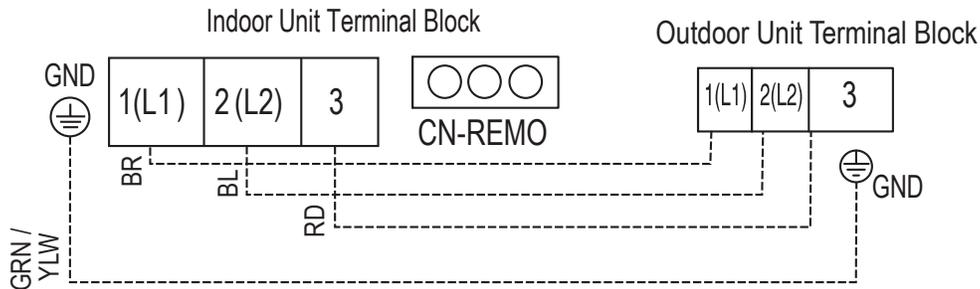

Figure 39: Wired Controller Connection on the Indoor Unit Terminal Block.



### Note:

When using field-supplied controller cable, make sure to connect the yellow to yellow (communications wire), red to red (12V power wire), and black to black (ground wire) terminals from the remote controller to the indoor unit terminal blocks.

# ELECTRICAL CONNECTIONS

## Wired Controller Placement

Wired controllers include a sensor to detect room temperature. To maintain comfort levels in the conditioned space, the wired controller must be installed in a location away from direct sunlight, high humidity, and where it could be directly exposed to cold air. Controller must be installed four (4) to five (5) feet above the floor where its LED display can be read easily, in an area with good air circulation, and where it can detect an average room temperature.

⊘ Do not install the wired controller near or in:

- Drafts or dead spots behind doors and in corners.
- Hot or cold air from ducts.
- Radiant heat from the sun or appliances.
- Concealed pipes and chimneys.
- An area where temperatures are uncontrolled, such as an outside wall.

Figure 40: Proper Location for the Wired Controller.

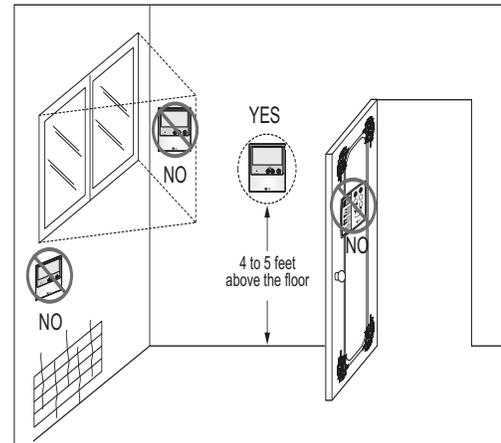

## Assigning the Thermistor for Temperature Detection

Each indoor unit includes a return air thermistor assigned to sense the temperature. If a wired controller is installed, there is a choice of sensing temperature with either the indoor unit return air thermistor or the thermistor in the wired controller. It is also an option to set both thermistors to sense temperature so that indoor unit bases its operation on the first thermistor to reach the designated temperature differential.

# EXTERNAL STATIC PRESSURE

Indoor Units

## Ceiling-Concealed Low Static Ducted External Static Pressure Settings

Table 27: Ceiling-Concealed Ducted (Low Static) Indoor Unit External Static Pressure Setting Values Table.

Static Pressure (in. wg)		0.0	0.04	0.08	0.12	0.16	0.20	
Model No. / Nominal Capacity of System (Btu/h)	Airflow Rate / CFM	Setting Value (in. wg)						
		LDN097HV4 9,000	High	318	98	103	108	116
Mid	247		82	88	94	102	110	118
Low	194		69	76	83	91	99	109
LDN127HV4 12,000	High	353	95	99	104	109	116	124
	Mid	300	86	91	96	101	108	116
	Low	247	78	82	87	93	100	108
LDN187HV4 18,000	High	530	123	125	129	134	141	145
	Mid	441	109	112	117	123	129	136
	Low	353	95	99	104	109	116	124

## Ceiling-Concealed High Static Ducted External Static Pressure Settings

Table 28: Ceiling-Concealed Ducted (High Static) LHN248HV Indoor Unit External Static Pressure Setting Values Table.

Static Pressure (in. wg)		0.1	0.16	0.2	0.24	0.28	0.31	0.35	0.39	0.43	0.47	0.51	0.59	
Model No. / Nominal Capacity of System (Btu/h)	Airflow Rate / CFM	Setting Value (in. wg)												
		LHN248HV 24,000	High	777	110	117	121	124	127	130	133	136	137	-
Mid	706		102	110	114	118	120	125	127	130	133	-	134	136
Low	636		96	102	107	110	114	118	122	125	127	-	130	132

Table 29: Ceiling-Concealed Ducted (High Static) LHN368HV Indoor Unit External Static Pressure Setting Values Table.

Static Pressure (in. wg)		0.1	0.16	0.2	0.24	0.28	0.31	0.35	0.39	0.43	0.47	0.51	0.59	
Model No. / Nominal Capacity of System (Btu/h)	Airflow Rate / CFM	Setting Value (in. wg)												
		LHN368HV 36,000	High	1,130	-	109	112	115	119	122	126	128	131	134
Mid	989		-	101	105	108	112	115	119	123	127	130	133	138
Low	848		-	92	97	101	105	109	113	117	121	124	127	134

### Note:

- To get the desired air flow and external static pressure combination, use the setting value from the table. Using a setting value other than that listed in the table will not provide the desired combination.
- Table data is based at 230V. Air flow rate varies according to voltage fluctuation.

# EXTERNAL STATIC PRESSURE

## Indoor Units

### Setting the External Static Pressure on the Remote Controller

Use this function to set the wind strength for each airflow level.

#### Note:

- The external static pressure must be set by a trained service provider, and it must be set correctly. If the external static pressure is set incorrectly, the product may malfunction.
- Do not alter the external static pressure value that corresponds to each airflow level.
- External static pressure values vary according to the model.
- When the airflow rate is increased to a higher value, during the external static value setup, the previous airflow value will be stored in the system memory. (External static pressure values are saved to system memory before the changes are implemented).

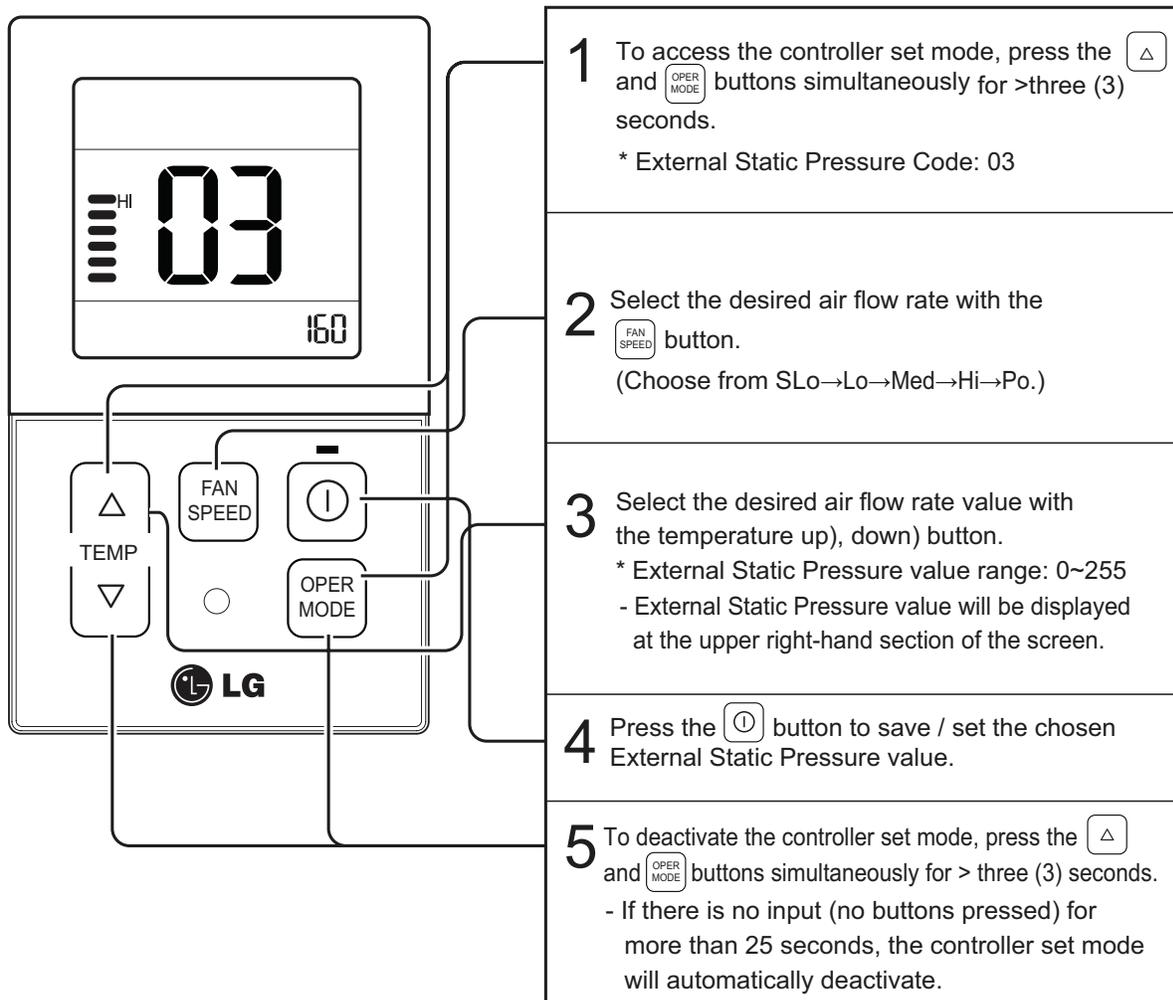

## Ceiling-Concealed Ducted Indoor Unit Accessories

Table 30: Ceiling-Concealed Ducted Indoor Unit Accessories.

Model No.	Description
ZLABGP04A	Low Ambient Wind Baffle for Low Static Ducted Indoor Units
ZLABGP01A	Low Ambient Wind Baffle for Low Static Ducted Indoor Units
ZFBXM101A	High Efficiency Filter Box for High Static Ducted Indoor Unit LHN248HV
ZFBXM201A	High Efficiency Filter Box for High Static Ducted Indoor Unit LHN368HV
ZFBXD201A	Dynamic V8 2VL Low Profile Air Cleaner for High Static Ducted Indoor Units
ZPLMV201A	Dynamic 2VL Air Cleaner Low Profile Return Air Plenum for High Static Ducted Indoor Units
ZFBXD402A	Dynamic V8 4VL Low Profile Air Cleaner for High Static Ducted Indoor Units
ZPLMV402A	Dynamic 4VL Air Cleaner Low Profile Return Air Plenum for High Static Ducted Indoor Units
ZFLT1301A	4-Pack Dynamic V8 VL Air Cleaner Replacement Filter Pads for High Static Ducted Indoor Units
ZFLT1302A	24-Pack Dynamic V8 VL Air Cleaner Replacement Filter Pads for High Static Ducted Indoor Units
ZGRLRA01A	Dynamic V8 Air Cleaner Louvered Return Air Grille (one per plenum) for High Static Ducted Indoor Units
ZGRLRA02A	Dynamic V8 Air Cleaner Egg Crate Return Air Grille (one per plenum) for High Static Ducted Indoor Units

## Drain Pan Heater

Figure 41: Drain Pan Heater.



Table 31: Drain Pan Heater Capacities.

ODU	Heater kW	Accessory Model	Note
LUU097HV	120W	PQSH1202	Optional
LUU127HV	120W	PQSH1202	Optional
LUU189HV	120W	PQSH1200	Optional
LUU249HV	120W	PQSH1200	Optional
LUU369HV	120W	PQSH1200	Optional

# ACCESSORIES

## LG Monitoring View (LGMV) Diagnostic Software and Cable

LGMV software allows the service technician or commissioning agent to connect a computer USB port to the outdoor unit main printed circuit board (PCB) using an accessory cable without the need for a separate interface device. The main screen for LGMV allows the user to view the following real time data on one screen:

- Actual inverter compressor speed
- Target inverter compressor speed
- Actual outdoor fan speed
- Target outdoor unit fan speed
- Actual superheat
- Target superheat
- Actual subcooler circuit superheat
- Target subcooler circuit superheat
- Main EEV position
- Subcooling EEV position
- Inverter compressor current transducer value
- Outdoor air temperature
- Actual high pressure/saturation temperature
- Actual low pressure/saturation temperature
- Suction temperature
- Inverter compressor discharge temperature
- Constant speed compressor discharge temperature
- Front outdoor coil pipe temperature
- Back outdoor coil pipe temperature
- Liquid line pipe temperature
- Subcooler inlet temperature
- Subcooler outlet temperature
- Average indoor unit (IDU) pipe temperature
- Inverter compressor operation indicator light
- Four-way reversing valve operation indicator light
- Pressure graph showing actual low pressure and actual high pressure levels
- Error code display
- Operating mode indicator
- Target high pressure
- Target low pressure
- PCB (printed circuit board) version
- Software version
- Installer name



- Model no. of outdoor units
- Site name
- Total number of connected indoor units
- Communication indicator lights
- Indoor unit capacity
- Indoor unit operating mode
- Indoor unit fan speed
- Indoor unit EEV position
- Indoor unit room temperature
- Indoor unit inlet pipe temperature
- Indoor unit outlet pipe temperature
- Indoor unit error code

Additional screens can be accessed by tabs on the main screen:

1. Cycleview: Graphic of internal components including:
  - Compressors showing actual speeds
  - EEVs
  - Indoor Units
  - Liquid injection valves
  - Temperature and pressure sensors
  - Four-way reversing valve
  - Outdoor fans showing status and speeds
2. Graph: Full screen graph of actual high and low pressures and high and low pressure limits. A sliding bar enables user to go back in time and view data.
3. Control IDU: Enables user to turn on all IDU's default setpoints of 86°F in heat mode or 64°F in cool mode.
4. Setting: Converts metric values to imperial values.
5. Making Data: Recording of real time data to a separate file created to be stored on the user's computer.
6. Loading Data: Recorded data from a saved ".CSV" file can be loaded to create an LGMV session.
7. Electrical Data: The lower half of main screen is changed to show the following:
  - Inverter compressor
    - Amps
    - Volts
    - Power Hz
    - Inverter control board fan Hz
  - Constant compressor
    - Current transducer value
    - Phase

Figure 42: Sample Cycleview.

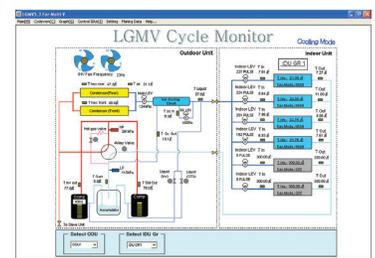

In lieu of connecting to the outdoor unit, user has the option to connect to the indoor unit with the use of a USB to RS-485 connector kit. When connected through the indoor unit, user will not be able to record data.

This software can be used to both commission new systems and troubleshoot existing systems. LGMV data can be recorded to a ".CSV" file and emailed to an LG representative to assist with diagnostic evaluations.

### Recommended Minimum PC Configuration:

- CPU: Pentium® IV 1.6 GHz
- Operating System: Windows® NT/2000/XP/Vista
- Main Memory: 256 MB
- Hard Disk: 600 MB when operating
- Web Browser: Internet Explorer® 5.0

**LGMV is available in different formats, including Mobile LGMV, which is a app for use on wireless devices. Contact your LG Sales Representative for more information.**

## LG Smart Inverter Monitoring System (SIMS)

SIMS can be used to display and graph operational data for single zone systems and respective components (indoor unit and outdoor unit). SIMS also displays error codes and a troubleshooting guide. SIMS consists of a hardware Wireless Local Area Network (WLAN) module, an interface cable, and a free downloadable application (app) for iOS® or Android™. The user must supply either an Apple® or an Android smart phone; SIMS is not optimized for tablets, and only be used with LG single zone and Multi F systems.

Only trained HVAC service technicians familiar with variable refrigerant flow (VRF) systems in general and with LG's DFS products can use SIMS. The technician must understand inverter air conditioning operation cycles, the meaning of the data displayed by SIMS, and how to use the data to troubleshoot the system.

*iOS is a registered trademark of Cisco in the U.S. and other countries. Android is a trademark of Google Inc. Apple is a trademark of Apple Inc., registered in the U.S. and other countries.*

**Contact your LG Sales Representative for system requirements, the latest version of SIMS, how to download the app, or other information.**

Figure 43: LG SIMS WLAN Module.



## LG Smart ThinQ

LG Smart ThinQ is a built-in Wi-Fi module, along with a free smart phone app that provides monitoring and remote control capabilities for certain LG single zone systems. The app has the following features and benefits:

- Sign in to the app using LG credentials, or using Google® or Facebook® login credentials. Users only have to log in to the app once; the app remembers login details for subsequent logins.
- View current temperature settings of the air conditioning unit and change temperature, fan speed, and air flow direction from anywhere in the house or at a remote location (through the use of wireless connection). Multiple users can control the household air conditioning unit remotely.
- Monitor filter usage of the unit.
- Set up weekly schedules to start and stop air conditioner activity.
- Set up the unit to run in different Modes, depending on the user's schedule. Set up specific temperatures for when the user is home, away on vacation, or sleeping.
- Troubleshoot problems, and view tips on general maintenance of the system using the Smart Diagnosis function.

*\*Google is a registered trademark of Google Inc.; Facebook is a registered trademark of Facebook.*

**Contact your LG Sales Representative or visit [www.lg-dfs.com](http://www.lg-dfs.com) for system requirements, how to download the app, a user's manual, or other information.**

Figure 44: Example of an LG Smart ThinQ Screen (appearance may differ depending on version of software).

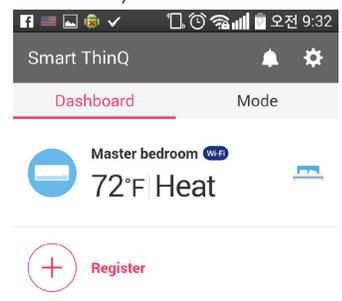

# CEILING-CONCEALED DUCTED UNIT PERFORMANCE DATA

[Cooling Capacity Data on page 53](#)

[Heating Capacity Data on page 58](#)

[Maximum Heating Capacity Data on page 63](#)

# PERFORMANCE DATA

## Low Static Ducted Cooling Capacity Tables

### Cooling Capacity Table for LD097HV4 (LDN097HV4 + LUU097HV)

Table 32: LD097HV4 Ceiling-Concealed Ducted (Low Static) System Cooling Capacity Table.

Outdoor Air Temp. (°F DB)	Indoor Air Temp. °F DB / °F WB																	
	68 / 57			73 / 61			77 / 64			80 / 67			86 / 72			90 / 75		
	TC	SHC	PI	TC	SHC	PI	TC	SHC	PI	TC	SHC	PI	TC	SHC	PI	TC	SHC	PI
-4	8.85	6.84	0.42	9.40	7.23	0.44	9.95	7.00	0.45	10.34	7.15	0.46	11.05	7.21	0.47	11.60	7.34	0.47
0	8.84	6.88	0.42	9.39	7.27	0.44	9.94	7.04	0.46	10.34	7.19	0.46	11.04	7.25	0.47	11.59	7.39	0.48
5	8.84	6.94	0.43	9.38	7.33	0.45	9.93	7.10	0.46	10.33	7.25	0.47	11.03	7.31	0.48	11.58	7.45	0.49
10	8.83	7.00	0.44	9.38	7.39	0.45	9.93	7.16	0.47	10.32	7.31	0.48	11.02	7.37	0.48	11.57	7.51	0.49
15	8.82	7.05	0.44	9.37	7.45	0.46	9.92	7.21	0.48	10.31	7.37	0.48	11.01	7.43	0.49	11.56	7.57	0.50
20	8.82	7.11	0.45	9.36	7.51	0.47	9.91	7.27	0.48	10.31	7.42	0.49	11.01	7.49	0.50	11.55	7.63	0.51
25	8.81	7.16	0.46	9.36	7.57	0.47	9.90	7.33	0.49	10.30	7.48	0.50	11.00	7.54	0.51	11.54	7.69	0.52
30	8.80	7.22	0.46	9.35	7.63	0.48	9.90	7.38	0.50	10.29	7.54	0.50	10.99	7.60	0.51	11.54	7.75	0.52
35	8.80	7.27	0.47	9.34	7.68	0.49	9.89	7.44	0.50	10.28	7.60	0.51	10.98	7.66	0.52	11.53	7.81	0.53
40	8.79	7.33	0.48	9.33	7.74	0.49	9.88	7.50	0.51	10.27	7.65	0.52	10.97	7.72	0.53	11.52	7.86	0.54
45	8.78	7.38	0.48	9.33	7.80	0.50	9.87	7.55	0.52	10.27	7.71	0.52	10.96	7.78	0.53	11.51	7.92	0.55
50	8.78	7.44	0.49	9.32	7.86	0.51	9.87	7.61	0.53	10.26	7.77	0.53	10.96	7.83	0.54	11.50	7.98	0.55
55	8.77	7.49	0.50	9.31	7.91	0.51	9.86	7.66	0.53	10.25	7.82	0.54	10.95	7.89	0.55	11.49	8.04	0.56
60	8.76	7.55	0.50	9.31	7.97	0.52	9.85	7.72	0.54	10.24	7.88	0.55	10.94	7.95	0.56	11.48	8.10	0.57
65	8.76	7.60	0.51	9.30	8.03	0.53	9.84	7.77	0.55	10.24	7.94	0.55	10.93	8.00	0.56	11.47	8.16	0.57
70	8.75	7.65	0.51	9.29	8.09	0.53	9.84	7.83	0.55	10.23	7.99	0.56	10.92	8.06	0.57	11.47	8.21	0.58
75	8.54	7.53	0.54	9.08	7.96	0.56	9.62	7.72	0.58	10.01	7.89	0.59	10.71	7.96	0.60	11.25	8.12	0.61
80	8.33	7.40	0.57	8.87	7.84	0.59	9.41	7.61	0.61	9.80	7.78	0.62	10.49	7.86	0.63	11.03	8.03	0.64
85	8.12	7.27	0.60	8.66	7.71	0.62	9.20	7.49	0.64	9.59	7.66	0.65	10.28	7.76	0.66	10.82	7.92	0.68
90	7.91	7.13	0.63	8.45	7.57	0.65	8.99	7.37	0.67	9.37	7.55	0.68	10.06	7.65	0.69	10.60	7.82	0.71
95	7.68	7.05	0.65	8.22	7.50	0.68	8.75	7.31	0.70	<b>9.00</b>	<b>7.38</b>	<b>0.71</b>	9.83	7.61	0.72	10.36	7.79	0.74
100	7.50	6.86	0.68	8.03	7.31	0.71	8.57	7.14	0.73	8.88	7.27	0.74	9.64	7.44	0.75	10.17	7.63	0.77
105	7.31	6.68	0.71	7.84	7.13	0.73	8.38	6.96	0.76	8.77	7.15	0.77	9.45	7.28	0.78	9.99	7.47	0.80
110	7.12	6.45	0.74	7.66	6.89	0.76	8.19	6.75	0.79	8.58	6.94	0.80	9.26	7.07	0.82	9.80	7.26	0.83
115	6.94	6.25	0.76	7.47	6.70	0.79	8.01	6.57	0.82	8.39	6.76	0.83	9.08	6.90	0.85	9.61	7.10	0.86
118	6.82	6.21	0.78	7.36	6.66	0.81	7.89	6.54	0.84	8.28	6.73	0.85	8.96	6.88	0.86	9.50	7.08	0.88
122	6.79	6.19	0.80	7.32	6.65	0.83	7.86	6.52	0.86	8.24	6.72	0.87	8.93	6.87	0.89	9.46	7.07	0.91

Product Data

TC = Total Capacity (kBtu/h).

SHC: Sensible Heat Capacity (kBtu/h).

PI = Power input (KW). Power input (KW) includes compressor and fan(s).

Nominal capacity as rated 0 ft. above sea level and a 0 ft. level difference between outdoor and indoor unit. Corresponding refrigerant piping length is accordance with standard length of each outdoor unit.

Nominal cooling capacity rating obtained with air entering the indoor unit at 80°F dry bulb (DB) and 67°F wet bulb (WB), and outdoor ambient conditions of 95°F dry bulb (DB) and 75°F wet bulb (WB).

Cooling range can be extended from 0°F down to -4°F using the Low Ambient Wind Baffle Kit (sold separately).

The shaded table rows indicate reference data. When operating at this temperature, these values can be different if the system is not running consistently.



# PERFORMANCE DATA

## Low Static Ducted Cooling Capacity Tables

### Cooling Capacity Table for LD127HV4 (LDN127HV4 + LUU127HV)

Table 33: LD127HV4 Ceiling-Concealed Ducted (Low Static) System Cooling Capacity Table.

Outdoor Air Temp. (°F DB)	Indoor Air Temp. °F DB / °F WB																	
	68 / 57			73 / 61			77 / 64			80 / 67			86 / 72			90 / 75		
	TC	SHC	PI	TC	SHC	PI	TC	SHC	PI	TC	SHC	PI	TC	SHC	PI	TC	SHC	PI
-4	11.40	9.03	0.53	12.11	9.54	0.55	12.82	9.24	0.57	13.33	9.43	0.58	14.24	9.51	0.59	14.95	9.69	0.60
0	11.40	9.08	0.54	12.11	9.60	0.56	12.81	9.29	0.58	13.33	9.49	0.58	14.23	9.57	0.60	14.94	9.75	0.61
5	11.39	9.17	0.55	12.10	9.68	0.57	12.80	9.38	0.59	13.31	9.57	0.59	14.22	9.65	0.61	14.93	9.84	0.62
10	11.38	9.24	0.56	12.09	9.76	0.58	12.79	9.45	0.60	13.30	9.65	0.60	14.21	9.73	0.61	14.91	9.92	0.63
15	11.37	9.31	0.56	12.08	9.84	0.58	12.78	9.53	0.61	13.29	9.73	0.61	14.20	9.81	0.62	14.90	9.99	0.64
20	11.36	9.39	0.57	12.07	9.91	0.59	12.77	9.60	0.61	13.28	9.80	0.62	14.19	9.88	0.63	14.89	10.07	0.65
25	11.35	9.46	0.58	12.06	9.99	0.60	12.76	9.67	0.62	13.27	9.88	0.63	14.17	9.96	0.64	14.88	10.15	0.65
30	11.35	9.53	0.59	12.05	10.07	0.61	12.75	9.75	0.63	13.26	9.95	0.64	14.16	10.04	0.65	14.87	10.23	0.66
35	11.34	9.60	0.60	12.04	10.14	0.62	12.74	9.82	0.64	13.25	10.03	0.65	14.15	10.11	0.66	14.86	10.31	0.67
40	11.33	9.68	0.60	12.03	10.22	0.63	12.74	9.90	0.65	13.24	10.10	0.66	14.14	10.19	0.67	14.85	10.38	0.68
45	11.32	9.75	0.61	12.02	10.30	0.63	12.73	9.97	0.66	13.23	10.18	0.66	14.13	10.27	0.68	14.83	10.46	0.69
50	11.31	9.82	0.62	12.01	10.37	0.64	12.72	10.04	0.67	13.22	10.26	0.67	14.12	10.34	0.69	14.82	10.54	0.70
55	11.30	9.89	0.63	12.00	10.45	0.65	12.71	10.12	0.67	13.21	10.33	0.68	14.11	10.42	0.70	14.81	10.61	0.71
60	11.29	9.96	0.64	11.99	10.53	0.66	12.70	10.19	0.68	13.20	10.41	0.69	14.10	10.49	0.70	14.80	10.69	0.72
65	11.28	10.04	0.64	11.99	10.60	0.67	12.69	10.26	0.69	13.19	10.48	0.70	14.09	10.57	0.71	14.79	10.77	0.73
70	11.28	10.11	0.65	11.98	10.68	0.68	12.68	10.34	0.70	13.18	10.56	0.71	14.08	10.64	0.72	14.78	10.85	0.74
75	11.00	9.94	0.69	11.70	10.51	0.71	12.40	10.19	0.74	12.91	10.41	0.75	13.80	10.52	0.76	14.50	10.72	0.78
80	10.73	9.77	0.72	11.43	10.35	0.75	12.13	10.04	0.78	12.63	10.27	0.79	13.52	10.38	0.80	14.22	10.60	0.82
85	10.46	9.59	0.76	11.16	10.17	0.79	11.85	9.89	0.81	12.36	10.12	0.82	13.24	10.24	0.84	13.94	10.46	0.86
90	10.20	9.41	0.79	10.89	10.00	0.82	11.58	9.73	0.85	12.08	9.96	0.86	12.97	10.10	0.88	13.66	10.33	0.90
95	9.90	9.31	0.83	10.59	9.91	0.86	11.28	9.65	0.89	<b>11.60</b>	<b>9.74</b>	<b>0.90</b>	12.66	10.05	0.92	13.35	10.28	0.94
100	9.66	9.06	0.86	10.35	9.66	0.89	11.04	9.42	0.93	11.45	9.59	0.94	12.42	9.83	0.96	13.11	10.07	0.98
105	9.42	8.81	0.90	10.11	9.41	0.93	10.80	9.19	0.97	11.30	9.44	0.98	12.18	9.61	0.99	12.87	9.86	1.01
110	9.18	8.51	0.93	9.87	9.10	0.97	10.56	8.91	1.00	11.06	9.16	1.01	11.94	9.34	1.03	12.63	9.59	1.05
115	8.94	8.26	0.97	9.63	8.85	1.00	10.32	8.67	1.04	10.82	8.93	1.05	11.70	9.12	1.07	12.39	9.37	1.09
118	8.79	8.20	0.99	9.48	8.79	1.03	10.17	8.63	1.06	10.67	8.89	1.08	11.55	9.09	1.10	12.24	9.35	1.12
122	8.75	8.18	1.02	9.44	8.77	1.06	10.13	8.61	1.09	10.62	8.87	1.11	11.51	9.08	1.13	12.20	9.34	1.15

TC = Total Capacity (kBtu/h).

SHC = Sensible Heat Capacity (kBtu/h).

PI = Power input (KW). Power input (KW) includes compressor and fan(s).

Nominal capacity as rated 0 ft. above sea level and a 0 ft. level difference between outdoor and indoor unit. Corresponding refrigerant piping length is accordance with standard length of each outdoor unit.

Nominal cooling capacity rating obtained with air entering the indoor unit at 80°F dry bulb (DB) and 67°F wet bulb (WB), and outdoor ambient conditions of 95°F dry bulb (DB) and 75°F wet bulb (WB).

Cooling range can be extended from 0°F down to -4°F using the Low Ambient Wind Baffle Kit (sold separately).

The shaded table rows indicate reference data. When operating at this temperature, these values can be different if the system is not running consistently.

# PERFORMANCE DATA

## Low Static Ducted Cooling Capacity Tables

### Cooling Capacity Table for LD187HV4 (LDN187HV4 + LUU189HV)

Table 34: LD187HV4 Ceiling-Concealed Ducted (Low Static) System Cooling Capacity Table.

Outdoor Air Temp. (°F DB)	Indoor Air Temp. °F DB / °F WB																	
	68 / 57			72 / 61			77 / 64			80 / 67			86 / 72			90 / 75		
	TC	SHC	PI	TC	SHC	PI	TC	SHC	PI	TC	SHC	PI	TC	SHC	PI	TC	SHC	PI
-4	17.70	12.40	0.92	18.80	13.10	0.96	19.89	12.68	0.99	20.69	12.95	1.00	22.09	13.06	1.02	23.19	13.31	1.04
0	17.69	12.47	0.93	18.79	13.18	0.97	19.88	12.76	1.00	20.68	13.03	1.01	22.08	13.14	1.03	23.18	13.39	1.05
5	17.67	12.58	0.95	18.77	13.29	0.98	19.87	12.87	1.02	20.66	13.14	1.03	22.06	13.25	1.05	23.16	13.50	1.07
10	17.66	12.68	0.96	18.76	13.40	1.00	19.85	12.97	1.03	20.64	13.24	1.05	22.05	13.36	1.07	23.14	13.61	1.09
15	17.65	12.78	0.98	18.74	13.50	1.01	19.84	13.07	1.05	20.63	13.35	1.06	22.03	13.46	1.08	23.12	13.72	1.10
20	17.63	12.88	0.99	18.73	13.61	1.03	19.82	13.18	1.06	20.61	13.45	1.08	22.01	13.57	1.10	23.11	13.82	1.12
25	17.62	12.98	1.00	18.71	13.71	1.04	19.81	13.28	1.08	20.60	13.56	1.09	22.00	13.67	1.11	23.09	13.93	1.13
30	17.60	13.08	1.02	18.70	13.82	1.06	19.79	13.38	1.09	20.58	13.66	1.11	21.98	13.78	1.13	23.07	14.04	1.15
35	17.59	13.18	1.03	18.68	13.92	1.07	19.78	13.48	1.11	20.57	13.77	1.12	21.96	13.88	1.14	23.05	14.14	1.17
40	17.58	13.28	1.05	18.67	14.03	1.08	19.76	13.58	1.12	20.55	13.87	1.14	21.94	13.99	1.16	23.04	14.25	1.18
45	17.56	13.38	1.06	18.66	14.13	1.10	19.75	13.68	1.14	20.53	13.97	1.15	21.93	14.09	1.17	23.02	14.36	1.20
50	17.55	13.48	1.07	18.64	14.24	1.11	19.73	13.79	1.15	20.52	14.08	1.17	21.91	14.19	1.19	23.00	14.46	1.21
55	17.54	13.58	1.09	18.63	14.34	1.13	19.72	13.89	1.17	20.50	14.18	1.18	21.89	14.30	1.21	22.98	14.57	1.23
60	17.52	13.68	1.10	18.61	14.45	1.14	19.70	13.99	1.18	20.49	14.28	1.20	21.88	14.40	1.22	22.97	14.68	1.25
65	17.51	13.77	1.12	18.60	14.55	1.16	19.69	14.09	1.20	20.47	14.38	1.21	21.86	14.51	1.24	22.95	14.78	1.26
70	17.50	13.87	1.13	18.58	14.65	1.17	19.67	14.19	1.21	20.46	14.49	1.23	21.84	14.61	1.25	22.93	14.89	1.28
75	17.08	13.64	1.19	18.16	14.43	1.24	19.24	13.99	1.28	20.03	14.29	1.29	21.41	14.43	1.32	22.50	14.72	1.35
80	16.66	13.41	1.25	17.74	14.20	1.30	18.82	13.79	1.35	19.60	14.10	1.36	20.98	14.25	1.39	22.06	14.55	1.41
85	16.24	13.17	1.31	17.32	13.96	1.36	18.40	13.57	1.41	19.17	13.89	1.43	20.55	14.06	1.45	21.63	14.36	1.48
90	15.82	12.92	1.37	16.90	13.72	1.42	17.97	13.35	1.48	18.75	13.68	1.49	20.12	13.86	1.52	21.20	14.17	1.55
95	15.37	12.78	1.44	16.44	13.60	1.49	17.51	13.25	1.54	<b>18.00</b>	<b>13.37</b>	<b>1.56</b>	19.65	13.79	1.59	20.72	14.11	1.62
100	14.99	12.44	1.50	16.06	13.25	1.55	17.13	12.93	1.61	17.77	13.17	1.63	19.28	13.49	1.66	20.35	13.82	1.69
105	14.62	12.10	1.56	15.69	12.91	1.61	16.76	12.62	1.67	17.53	12.96	1.69	18.90	13.19	1.72	19.97	13.53	1.76
110	14.24	11.68	1.62	15.32	12.49	1.68	16.39	12.23	1.74	17.16	12.57	1.76	18.53	12.82	1.79	19.60	13.16	1.83
115	13.87	11.33	1.68	14.94	12.14	1.74	16.01	11.90	1.80	16.79	12.25	1.83	18.15	12.51	1.86	19.22	12.86	1.90
118	13.65	11.25	1.72	14.72	12.07	1.78	15.79	11.84	1.84	16.56	12.20	1.86	17.93	12.47	1.90	19.00	12.83	1.94
122	13.57	11.22	1.76	14.64	12.04	1.83	15.71	11.82	1.90	16.49	12.18	1.92	17.85	12.46	1.95	18.92	12.82	1.99

TC = Total Capacity (kBtu/h).  
 SHC: Sensible Heat Capacity (kBtu/h).  
 PI = Power input (KW). Power input (KW) includes compressor and fan(s).  
 Nominal capacity as rated 0 ft. above sea level and a 0 ft. level difference between outdoor and indoor unit. Corresponding refrigerant piping length is accordance with standard length of each outdoor unit.  
 Nominal cooling capacity rating obtained with air entering the indoor unit at 80°F dry bulb (DB) and 67°F wet bulb (WB), and outdoor ambient conditions of 95°F dry bulb (DB) and 75°F wet bulb (WB).

Cooling range can be extended from 0°F down to -4°F using the Low Ambient Wind Baffle Kit (sold separately).  
 The shaded table rows indicate reference data. When operating at this temperature, these values can be different if the system is not running consistently.

# PERFORMANCE DATA

## High Static Ducted Cooling Capacity Tables

### Cooling Capacity Table for LH248HV4 (LHN248HV + LUU249HV)

Table 35: LH248HV4 Ceiling-Concealed Ducted (High Static) System Cooling Capacity Table.

Outdoor Air Temp. (°F DB)	Indoor Air Temp. °F DB / °F WB																	
	68 / 57			72 / 61			77 / 64			80 / 67			86 / 72			90 / 75		
	TC	SHC	PI	TC	SHC	PI	TC	SHC	PI	TC	SHC	PI	TC	SHC	PI	TC	SHC	PI
-4	23.60	18.47	1.18	25.06	19.51	1.23	26.53	18.89	1.27	27.58	19.29	1.29	29.46	19.45	1.31	30.92	19.82	1.34
-0.4	23.58	18.58	1.20	25.05	19.63	1.24	26.51	19.00	1.29	27.57	19.40	1.30	29.44	19.57	1.32	30.91	19.94	1.35
5	23.56	18.74	1.22	25.03	19.80	1.26	26.49	19.17	1.31	27.55	19.57	1.32	29.42	19.74	1.35	30.88	20.11	1.37
10	23.55	18.89	1.23	25.01	19.95	1.28	26.47	19.32	1.33	27.53	19.73	1.34	29.39	19.89	1.37	30.86	20.27	1.39
15	23.53	19.04	1.25	24.99	20.11	1.30	26.45	19.47	1.34	27.50	19.88	1.36	29.37	20.05	1.39	30.83	20.43	1.41
20	23.51	19.19	1.27	24.97	20.27	1.32	26.43	19.63	1.36	27.48	20.04	1.38	29.35	20.21	1.41	30.81	20.59	1.43
25	23.49	19.34	1.29	24.95	20.43	1.33	26.41	19.78	1.38	27.46	20.19	1.40	29.33	20.36	1.43	30.79	20.75	1.45
30	23.47	19.48	1.31	24.93	20.58	1.35	26.39	19.93	1.40	27.44	20.35	1.42	29.30	20.52	1.45	30.76	20.91	1.47
35	23.46	19.63	1.32	24.91	20.74	1.37	26.37	20.08	1.42	27.42	20.50	1.44	29.28	20.68	1.47	30.74	21.07	1.49
40	23.44	19.78	1.34	24.89	20.89	1.39	26.35	20.23	1.44	27.40	20.66	1.46	29.26	20.83	1.49	30.72	21.23	1.52
45	23.42	19.93	1.36	24.87	21.05	1.41	26.33	20.38	1.46	27.38	20.81	1.48	29.24	20.99	1.51	30.69	21.38	1.54
50	23.40	20.07	1.38	24.85	21.21	1.43	26.31	20.53	1.48	27.36	20.97	1.50	29.21	21.14	1.52	30.67	21.54	1.56
55	23.38	20.22	1.40	24.84	21.36	1.45	26.29	20.68	1.50	27.34	21.12	1.52	29.19	21.30	1.54	30.64	21.70	1.58
60	23.37	20.37	1.41	24.82	21.52	1.47	26.27	20.83	1.52	27.32	21.27	1.54	29.17	21.45	1.56	30.62	21.86	1.60
65	23.35	20.52	1.43	24.80	21.67	1.48	26.25	20.98	1.54	27.29	21.43	1.56	29.15	21.61	1.58	30.60	22.02	1.62
70	23.33	20.66	1.45	24.78	21.83	1.50	26.23	21.13	1.56	27.27	21.58	1.58	29.13	21.76	1.60	30.57	22.17	1.64
75	22.77	20.32	1.53	24.21	21.49	1.58	25.66	20.84	1.64	26.70	21.29	1.66	28.55	21.50	1.69	29.99	21.92	1.73
80	22.21	19.97	1.61	23.65	21.16	1.66	25.09	20.53	1.73	26.13	21.00	1.75	27.97	21.23	1.78	29.42	21.66	1.81
85	21.65	19.61	1.68	23.09	20.80	1.75	24.53	20.21	1.81	25.57	20.69	1.83	27.40	20.94	1.86	28.84	21.39	1.90
90	21.09	19.24	1.76	22.53	20.44	1.83	23.96	19.89	1.89	25.00	20.37	1.92	26.83	20.65	1.95	28.27	21.11	1.99
95	20.49	19.04	1.84	21.92	20.25	1.91	23.35	19.73	1.98	<b>24.00</b>	<b>19.92</b>	<b>2.00</b>	26.20	20.54	2.04	27.63	21.02	2.08
100	19.99	18.53	1.92	21.42	19.74	1.99	22.85	19.26	2.06	23.69	19.61	2.08	25.70	20.09	2.12	27.13	20.59	2.17
105	19.49	18.02	2.00	20.92	19.23	2.07	22.35	18.79	2.15	23.38	19.30	2.17	25.20	19.65	2.21	26.63	20.16	2.26
110	18.99	17.40	2.07	20.42	18.61	2.15	21.85	18.21	2.23	22.88	18.73	2.25	24.70	19.09	2.30	26.13	19.60	2.34
115	18.49	16.88	2.15	19.92	18.09	2.23	21.35	17.73	2.31	22.38	18.25	2.34	24.20	18.64	2.38	25.63	19.16	2.43
118	18.19	16.76	2.20	19.62	17.98	2.28	21.05	17.64	2.36	22.08	18.17	2.39	23.90	18.57	2.44	25.33	19.11	2.48
122	18.10	16.72	2.26	19.52	17.94	2.35	20.95	17.61	2.43	21.98	18.14	2.46	23.81	18.55	2.50	25.23	19.09	2.56

TC = Total Capacity (kBtu/h).

SHC: Sensible Heat Capacity (kBtu/h).

PI = Power input (KW). Power input (KW) includes compressor and fan(s).

Nominal capacity as rated 0 ft. above sea level and a 0 ft. level difference between outdoor and indoor unit. Corresponding refrigerant piping length is accordance with standard length of each outdoor unit.

Nominal cooling capacity rating obtained with air entering the indoor unit at 80°F dry bulb (DB) and 67°F wet bulb (WB), and outdoor ambient conditions of 95°F dry bulb (DB) and 75°F wet bulb (WB).

Cooling range can be extended from 0°F down to -4°F using the Low Ambient Wind Baffle Kit (sold separately).

The shaded table rows indicate reference data. When operating at this temperature, these values can be different if the system is not running consistently.

# PERFORMANCE DATA

## High Static Ducted Cooling Capacity Tables

### Cooling Capacity Table for LH368HV4 (LHN368HV + LUU369HV)

Table 36: LH368HV4 Ceiling-Concealed Ducted (High Static) System Cooling Capacity Table.

Outdoor Air Temp. (°F DB)	Indoor Air Temp. °F DB / °F WB																	
	68 / 57			72 / 61			77 / 64			80 / 67			86 / 72			90 / 75		
	TC	SHC	PI	TC	SHC	PI	TC	SHC	PI	TC	SHC	PI	TC	SHC	PI	TC	SHC	PI
-4	35.39	25.44	1.76	37.59	26.87	1.83	39.79	26.02	1.89	41.38	26.56	1.92	44.19	26.79	1.95	46.38	27.30	1.99
-0.4	35.37	25.58	1.78	37.57	27.03	1.85	39.77	26.17	1.91	41.35	26.72	1.94	44.16	26.94	1.97	46.36	27.46	2.01
5	35.34	25.81	1.81	37.54	27.26	1.88	39.73	26.40	1.95	41.32	26.95	1.97	44.12	27.18	2.01	46.32	27.69	2.05
10	35.32	26.01	1.84	37.51	27.48	1.91	39.70	26.61	1.97	41.29	27.17	2.00	44.09	27.40	2.03	46.28	27.91	2.08
15	35.29	26.22	1.86	37.48	27.70	1.93	39.67	26.82	2.00	41.26	27.38	2.03	44.06	27.61	2.06	46.25	28.13	2.11
20	35.26	26.42	1.89	37.45	27.91	1.96	39.64	27.03	2.03	41.23	27.60	2.06	44.02	27.83	2.09	46.21	28.35	2.14
25	35.24	26.63	1.92	37.43	28.13	1.99	39.61	27.24	2.06	41.19	27.81	2.08	43.99	28.04	2.12	46.18	28.57	2.17
30	35.21	26.83	1.95	37.40	28.34	2.02	39.58	27.44	2.09	41.16	28.02	2.11	43.96	28.26	2.15	46.14	28.79	2.20
35	35.18	27.04	1.97	37.37	28.56	2.04	39.55	27.65	2.12	41.13	28.23	2.14	43.92	28.47	2.18	46.11	29.01	2.23
40	35.16	27.24	2.00	37.34	28.77	2.07	39.52	27.86	2.15	41.10	28.45	2.17	43.89	28.69	2.21	46.07	29.23	2.26
45	35.13	27.44	2.03	37.31	28.99	2.10	39.49	28.07	2.18	41.07	28.66	2.20	43.86	28.90	2.24	46.04	29.45	2.29
50	35.10	27.65	2.05	37.28	29.20	2.13	39.46	28.28	2.21	41.04	28.87	2.23	43.82	29.12	2.27	46.00	29.67	2.32
55	35.08	27.85	2.08	37.25	29.42	2.16	39.43	28.48	2.23	41.01	29.08	2.26	43.79	29.33	2.30	45.97	29.88	2.35
60	35.05	28.05	2.11	37.23	29.63	2.18	39.40	28.69	2.26	40.97	29.29	2.29	43.76	29.54	2.33	45.93	30.10	2.38
65	35.02	28.25	2.13	37.20	29.84	2.21	39.37	28.90	2.29	40.94	29.51	2.32	43.72	29.75	2.36	45.90	30.32	2.41
70	34.99	28.45	2.16	37.17	30.06	2.24	39.34	29.10	2.32	40.91	29.72	2.35	43.69	29.97	2.39	45.86	30.53	2.44
75	34.15	27.98	2.28	36.32	29.60	2.36	38.49	28.69	2.45	40.05	29.32	2.47	42.82	29.60	2.52	44.99	30.19	2.57
80	33.31	27.51	2.39	35.47	29.13	2.48	37.64	28.28	2.57	39.20	28.91	2.60	41.96	29.23	2.65	44.12	29.83	2.70
85	32.48	27.00	2.51	34.63	28.64	2.60	36.79	27.83	2.70	38.35	28.49	2.73	41.10	28.84	2.78	43.26	29.46	2.83
90	31.64	26.49	2.63	33.79	28.14	2.72	35.94	27.38	2.82	37.50	28.05	2.85	40.25	28.43	2.91	42.40	29.07	2.97
95	30.74	26.22	2.74	32.88	27.89	2.84	35.02	27.18	2.95	<b>36.00</b>	<b>27.43</b>	<b>2.98</b>	39.30	28.28	3.04	41.44	28.95	3.10
100	29.99	25.51	2.86	32.13	27.19	2.96	34.27	26.53	3.07	35.53	27.01	3.11	38.55	27.67	3.16	40.69	28.35	3.23
105	29.24	24.81	2.98	31.38	26.48	3.08	33.52	25.88	3.20	35.07	26.58	3.23	37.80	27.06	3.29	39.94	27.76	3.36
110	28.49	23.96	3.09	30.63	25.63	3.20	32.77	25.08	3.32	34.32	25.79	3.36	37.05	26.29	3.42	39.20	27.00	3.49
115	27.74	23.25	3.21	29.88	24.91	3.33	32.02	24.42	3.45	33.57	25.13	3.49	36.31	25.67	3.55	38.45	26.38	3.62
118	27.29	23.08	3.28	29.43	24.75	3.40	31.57	24.29	3.52	33.12	25.02	3.56	35.86	25.58	3.63	38.00	26.31	3.70
122	27.14	23.02	3.37	29.28	24.70	3.49	31.43	24.25	3.62	32.97	24.98	3.66	35.71	25.55	3.73	37.85	26.29	3.81

TC = Total Capacity (kBtu/h).

SHC: Sensible Heat Capacity (kBtu/h).

PI = Power input (KW). Power input (KW) includes compressor and fan(s).

Nominal capacity as rated 0 ft. above sea level and a 0 ft. level difference between outdoor and indoor unit. Corresponding refrigerant piping length is accordance with standard length of each outdoor unit.

Nominal cooling capacity rating obtained with air entering the indoor unit at 80°F dry bulb (DB) and 67°F wet bulb (WB), and outdoor ambient conditions of 95°F dry bulb (DB) and 75°F wet bulb (WB).

Cooling range can be extended from 0°F down to -4°F using the Low Ambient Wind Baffle Kit (sold separately).

The shaded table rows indicate reference data. When operating at this temperature, these values can be different if the system is not running consistently.

# PERFORMANCE DATA

## Low Static Ducted Heating Capacity Tables

### Heating Capacity Table for LD097HV4 (LDN097HV4 + LUU097HV)

Table 37: LD097HV4 Ceiling-Concealed Ducted (Low Static) System Heating Capacity Table.

Outdoor Air Temp.		Indoor Air Temp. °F DB											
°F DB	°F WB	61		64		68		70		72		75	
		TC	PI	TC	PI	TC	PI	TC	PI	TC	PI	TC	PI
-4	-4.4	8.12	0.86	7.68	0.90	7.53	0.90	7.42	0.91	7.33	0.91	7.03	0.95
0	-0.4	8.58	0.89	8.16	0.93	7.98	0.94	7.85	0.95	7.75	0.95	7.43	0.99
5	4.5	9.14	0.93	8.74	0.96	8.52	0.98	8.38	0.99	8.26	1.00	7.93	1.04
10	9	9.66	0.97	9.28	1.00	9.01	1.02	8.86	1.04	8.73	1.05	8.39	1.08
17	15	10.35	1.01	9.99	1.05	9.68	1.08	9.50	1.10	9.36	1.11	9.00	1.14
20	19	10.81	1.04	10.47	1.08	10.12	1.11	9.93	1.13	9.78	1.15	9.41	1.18
25	23	11.58	1.10	11.24	1.13	10.85	1.17	10.64	1.20	10.48	1.22	10.08	1.25
30	28	12.36	1.16	11.98	1.20	11.57	1.24	11.36	1.26	11.19	1.28	10.78	1.32
35	32	13.14	1.22	12.73	1.26	12.29	1.30	12.07	1.33	11.89	1.35	11.46	1.38
40	36	13.81	1.26	13.43	1.30	13.00	1.34	12.77	1.36	12.59	1.39	12.14	1.42
45	41	14.65	1.30	14.30	1.34	13.88	1.39	13.65	1.41	13.46	1.43	12.98	1.47
47	43	14.99	1.32	14.65	1.36	14.23	1.41	<b>14.00</b>	<b>1.43</b>	13.81	1.45	13.31	1.49
50	46	15.03	1.31	14.73	1.35	14.36	1.39	14.15	1.41	13.99	1.43	13.52	1.46
55	51	15.10	1.30	14.85	1.33	14.58	1.36	14.41	1.38	14.28	1.39	13.85	1.42
60	56	15.18	1.28	14.98	1.31	14.80	1.33	14.67	1.34	14.57	1.35	14.19	1.37
63	59	15.22	1.27	15.05	1.29	14.92	1.31	14.82	1.32	14.74	1.33	14.40	1.34
68	64	15.26	1.27	15.13	1.28	15.06	1.30	14.98	1.30	14.92	1.30	14.61	1.31

TC = Total Capacity (kBtu/h).

PI = Power input (KW). Power input (KW) includes compressor and fan(s).

Nominal capacity as rated 0 ft. above sea level and a 0 ft. level difference between outdoor and indoor unit. Corresponding refrigerant piping length is accordance with standard length of each outdoor unit.

Nominal heating capacity rating obtained with air entering the indoor unit at 70°F dry bulb (DB) and 60°F wet bulb (WB), and outdoor ambient conditions of 47°F dry bulb (DB) and 43°F wet bulb (WB).

# PERFORMANCE DATA

## Low Static Ducted Heating Capacity Tables

### Heating Capacity Table for LD127HV4 (LDN127HV4 + LUU127HV)

Table 38: LD127HV4 Ceiling-Concealed Ducted (Low Static) System Heating Capacity Table.

Outdoor Air Temp.		Indoor Air Temp. °F DB											
°F DB	°F WB	61		64		68		70		72		75	
		TC	PI	TC	PI	TC	PI	TC	PI	TC	PI	TC	PI
-4	-4.4	5.93	0.93	5.48	0.97	5.46	0.98	5.40	0.99	5.35	0.99	5.11	1.03
0	-0.4	7.22	0.94	6.79	0.98	6.68	1.00	6.59	1.00	6.52	1.01	6.24	1.05
5	4.5	8.75	0.96	8.34	1.00	8.14	1.02	8.01	1.03	7.90	1.04	7.58	1.07
10	9	9.77	0.98	9.37	1.01	9.11	1.04	8.96	1.05	8.83	1.06	8.48	1.10
17	15	10.89	1.00	10.52	1.03	10.18	1.06	10.00	1.08	9.85	1.09	9.47	1.13
20	19	11.58	1.01	11.21	1.04	10.83	1.08	10.63	1.10	10.47	1.12	10.07	1.15
25	23	12.72	1.04	12.34	1.07	11.91	1.11	11.69	1.13	11.51	1.15	11.07	1.18
30	28	13.87	1.07	13.44	1.11	12.98	1.14	12.74	1.16	12.55	1.18	12.09	1.21
35	32	15.02	1.10	14.54	1.14	14.05	1.17	13.80	1.20	13.59	1.22	13.10	1.25
40	36	15.79	1.13	15.34	1.17	14.85	1.21	14.60	1.23	14.39	1.25	13.87	1.28
45	41	16.74	1.17	16.34	1.21	15.86	1.25	15.60	1.27	15.39	1.29	14.83	1.33
47	43	17.13	1.19	16.74	1.23	16.27	1.27	<b>16.00</b>	<b>1.29</b>	15.79	1.31	15.21	1.35
50	46	17.18	1.18	16.83	1.22	16.41	1.25	16.18	1.27	15.99	1.29	15.45	1.32
55	51	17.26	1.17	16.97	1.20	16.66	1.23	16.47	1.24	16.32	1.25	15.83	1.28
60	56	17.34	1.16	17.12	1.18	16.91	1.20	16.76	1.21	16.65	1.22	16.22	1.24
63	59	17.40	1.15	17.21	1.17	17.06	1.19	16.94	1.19	16.85	1.20	16.46	1.21
68	64	17.45	1.14	17.29	1.16	17.21	1.17	17.12	1.17	17.05	1.18	16.69	1.19

TC = Total Capacity (kBtu/h).

PI = Power input (KW). Power input (KW) includes compressor and fan(s).

Nominal capacity as rated 0 ft. above sea level and a 0 ft. level difference between outdoor and indoor unit. Corresponding refrigerant piping length is accordance with standard length of each outdoor unit.

Nominal heating capacity rating obtained with air entering the indoor unit at 70°F dry bulb (DB) and 60°F wet bulb (WB), and outdoor ambient conditions of 47°F dry bulb (DB) and 43°F wet bulb (WB).

# PERFORMANCE DATA

## Low Static Ducted Heating Capacity Tables

### Heating Capacity Table for LD187HV4 (LDN187HV4 + LUU189HV)

Table 39: LD187HV4 Ceiling-Concealed Ducted (Low Static) System Heating Capacity Table.

Outdoor Air Temp.		Indoor Air Temp. °F DB											
		61.0		64.0		68.0		70.0		72.0		75.0	
°F DB	°F WB	TC	PI	TC	PI	TC	PI	TC	PI	TC	PI	TC	PI
-4	-4.4	7.90	6.83	7.31	7.05	7.27	7.26	7.19	7.38	7.12	7.48	6.80	7.70
0	-0.4	9.44	6.41	8.88	6.61	8.74	6.82	8.62	6.93	8.52	7.02	8.16	7.22
5	4.5	11.27	5.89	10.74	6.08	10.48	6.27	10.31	6.37	10.18	6.46	9.77	6.64
10	9	12.49	5.42	11.98	5.59	11.65	5.77	11.45	5.86	11.29	5.94	10.85	6.11
17	15	13.84	4.79	13.36	4.94	12.93	5.10	12.70	5.18	12.51	5.25	12.03	5.40
20	19	14.65	4.37	14.19	4.51	13.71	4.65	13.46	4.73	13.25	4.79	12.75	4.93
25	23	16.02	3.95	15.54	4.07	15.00	4.20	14.72	4.27	14.49	4.33	13.95	4.45
30	28	17.40	3.42	16.86	3.53	16.28	3.64	15.98	3.70	15.74	3.75	15.16	3.86
35	32	18.78	3.00	18.18	3.10	17.56	3.20	17.24	3.25	16.99	3.29	16.38	3.39
40	36	19.73	2.58	19.18	2.66	18.57	2.75	18.25	2.80	17.99	2.83	17.34	2.92
45	41	20.93	2.05	20.43	2.12	19.83	2.19	19.50	2.23	19.24	2.26	18.54	2.32
47	43	21.41	1.84	20.93	1.91	20.33	1.97	<b>20.00</b>	<b>2.00</b>	19.73	2.03	19.02	2.09
50	46	21.47	1.83	21.04	1.89	20.52	1.94	20.22	1.97	19.98	1.99	19.31	2.05
55	51	21.58	1.81	21.22	1.86	20.83	1.90	20.59	1.92	20.40	1.94	19.79	1.98
60	56	21.68	1.79	21.40	1.83	21.14	1.86	20.95	1.88	20.81	1.89	20.28	1.92
63	59	21.74	1.78	21.51	1.81	21.32	1.84	21.18	1.85	21.06	1.85	20.57	1.88
68	64	21.81	1.77	21.62	1.79	21.51	1.81	21.40	1.82	21.31	1.82	20.86	1.84

TC = Total Capacity (kBtu/h).

PI = Power input (KW). Power input (KW) includes compressor and fan(s).

Nominal capacity as rated 0 ft. above sea level and a 0 ft. level difference between outdoor and indoor unit. Corresponding refrigerant piping length is accordance with standard length of each outdoor unit.

Nominal heating capacity rating obtained with air entering the indoor unit at 70°F dry bulb (DB) and 60°F wet bulb (WB), and outdoor ambient conditions of 47°F dry bulb (DB) and 43°F wet bulb (WB).

# PERFORMANCE DATA

## High Static Ducted Heating Capacity Tables

### Heating Capacity Table for LH248HV4 (LHN248HV + LUU249HV)

Table 40: LH248HV4 Ceiling-Concealed Ducted (High Static) System Heating Capacity Table.

Outdoor Air Temp.		Indoor Air Temperature:°F DB											
		61.0		64.0		68.0		70.0		72.0		75.0	
°F DB	°F WB	TC	PI	TC	PI	TC	PI	TC	PI	TC	PI	TC	PI
-4	-4.4	13.03	1.60	12.24	1.65	12.06	1.70	11.89	1.72	11.76	1.75	11.26	1.80
0	-0.4	14.47	1.63	13.71	1.68	13.44	1.73	13.23	1.75	13.07	1.78	12.53	1.83
5	4.5	16.07	1.66	15.34	1.71	14.96	1.76	14.72	1.79	14.52	1.81	13.94	1.87
10	9	17.43	1.69	16.73	1.74	16.26	1.80	15.98	1.83	15.76	1.85	15.14	1.90
17	15	19.07	1.73	18.40	1.78	17.82	1.84	17.50	1.87	17.24	1.89	16.58	1.95
20	19	20.10	1.76	19.46	1.81	18.81	1.87	18.46	1.90	18.18	1.93	17.49	1.98
25	23	21.84	1.78	21.19	1.84	20.46	1.90	20.07	1.93	19.76	1.96	19.02	2.01
30	28	23.60	1.82	22.87	1.88	22.08	1.93	21.67	1.97	21.35	1.99	20.57	2.05
35	32	25.35	1.84	24.54	1.90	23.71	1.96	23.28	2.00	22.94	2.02	22.11	2.08
40	36	26.64	1.87	25.89	1.93	25.07	1.99	24.63	2.03	24.29	2.05	23.41	2.12
45	41	28.26	1.90	27.58	1.97	26.77	2.03	26.32	2.07	25.97	2.09	25.02	2.16
47	43	28.90	1.92	28.26	1.98	27.45	2.04	<b>27.00</b>	<b>2.08</b>	26.64	2.11	25.67	2.17
50	46	28.99	1.91	28.40	1.96	27.70	2.02	27.30	2.05	26.98	2.07	26.07	2.13
55	51	29.13	1.89	28.65	1.93	28.12	1.98	27.79	2.00	27.54	2.02	26.72	2.06
60	56	29.27	1.87	28.89	1.90	28.53	1.94	28.29	1.95	28.09	1.96	27.38	1.99
63	59	29.35	1.85	29.03	1.88	28.78	1.91	28.59	1.92	28.43	1.93	27.77	1.95
68	64	29.44	1.84	29.18	1.87	29.04	1.89	28.89	1.89	28.77	1.90	28.17	1.91

TC = Total Capacity (kBtu/h).

PI = Power input (KW). Power input (KW) includes compressor and fan(s).

Nominal capacity as rated 0 ft. above sea level and a 0 ft. level difference between outdoor and indoor unit. Corresponding refrigerant piping length is accordance with standard length of each outdoor unit.

Nominal heating capacity rating obtained with air entering the indoor unit at 70°F dry bulb (DB) and 60°F wet bulb (WB), and outdoor ambient conditions of 47°F dry bulb (DB) and 43°F wet bulb (WB).

# PERFORMANCE DATA

## High Static Ducted Heating Capacity Tables

### Heating Capacity Table for LH368HV4 (LHN368HV + LUU369HV)

Table 41: LH368HV4 Ceiling-Concealed Duct (High Static) System Heating Capacity Table.

Outdoor Air Temp.		Indoor Air Temp. °F DB											
		61.0		64.0		68.0		70.0		72.0		75.0	
°F DB	°F WB	TC	PI	TC	PI	TC	PI	TC	PI	TC	PI	TC	PI
-4	-4.4	15.17	2.12	14.16	2.18	14.01	2.25	13.83	2.28	13.68	2.31	13.08	2.38
0	-0.4	17.79	2.18	16.81	2.25	16.50	2.31	16.26	2.35	16.06	2.38	15.39	2.45
5	4.5	20.70	2.25	19.74	2.32	19.26	2.39	18.95	2.43	18.70	2.47	17.95	2.54
10	9	23.18	2.32	22.24	2.40	21.62	2.47	21.25	2.51	20.95	2.54	20.12	2.62
17	15	26.15	2.41	25.24	2.49	24.44	2.57	24.00	2.61	23.65	2.64	22.74	2.72
20	19	28.03	2.47	27.14	2.55	26.24	2.63	25.75	2.68	25.36	2.71	24.40	2.79
25	23	31.19	2.54	30.27	2.62	29.21	2.70	28.66	2.74	28.22	2.78	27.16	2.86
30	28	34.37	2.61	33.31	2.70	32.17	2.78	31.58	2.83	31.10	2.87	29.96	2.95
35	32	37.55	2.67	36.36	2.76	35.12	2.85	34.49	2.90	33.98	2.93	32.76	3.02
40	36	39.47	2.73	38.36	2.82	37.14	2.91	36.49	2.96	35.98	3.00	34.68	3.09
45	41	41.86	2.81	40.86	2.90	39.66	2.99	39.00	3.05	38.47	3.09	37.07	3.18
47	43	42.82	2.84	41.86	2.93	40.66	3.03	<b>40.00</b>	<b>3.08</b>	39.47	3.12	38.03	3.22
50	46	42.94	2.82	42.08	2.91	41.04	2.99	40.44	3.04	39.97	3.07	38.62	3.15
55	51	43.15	2.79	42.44	2.86	41.65	2.93	41.18	2.96	40.79	2.99	39.59	3.05
60	56	43.36	2.76	42.80	2.82	42.27	2.87	41.91	2.89	41.62	2.91	40.56	2.95
63	59	43.49	2.74	43.01	2.79	42.64	2.83	42.35	2.84	42.12	2.86	41.14	2.89
68	64	43.61	2.73	43.23	2.76	43.02	2.79	42.80	2.80	42.62	2.81	41.73	2.83

TC = Total Capacity (kBtu/h).

PI = Power input (KW). Power input (KW) includes compressor and fan(s).

Nominal capacity as rated 0 ft. above sea level and a 0 ft. level difference between outdoor and indoor unit. Corresponding refrigerant piping length is accordance with standard length of each outdoor unit.

Nominal heating capacity rating obtained with air entering the indoor unit at 70°F dry bulb (DB) and 60°F wet bulb (WB), and outdoor ambient conditions of 47°F dry bulb (DB) and 43°F wet bulb (WB).

# PERFORMANCE DATA

## High Static Ducted Maximum Heating Capacity Tables

### Maximum Heating Capacity Table for LH248HV4 (LHN248HV + LUU249HV)

Table 42: LH248HV4 Ceiling-Concealed Duct (High Static) System Max Heating Capacity Table.

Outdoor Air Temp.		Indoor Air Temp. °F DB											
		61		64		68		70		72		75	
°F DB	°F WB	TC	PI	TC	PI	TC	PI	TC	PI	TC	PI	TC	PI
-13	-13.4	19.66	2.66	19.22	2.74	18.67	2.83	18.36	2.88	18.12	2.92	17.46	3.01
-4	-4.4	22.22	2.84	21.73	2.94	21.11	3.03	20.76	3.08	20.49	3.12	19.74	3.22
0	-0.4	23.57	2.95	23.05	3.05	22.39	3.15	22.02	3.20	21.73	3.24	20.94	3.34
5	4.5	25.26	3.09	24.70	3.19	23.99	3.29	23.60	3.35	23.29	3.40	22.44	3.50
10	9	26.36	2.78	25.77	2.88	25.04	2.97	24.63	3.02	24.30	3.06	23.42	3.15
17	15	27.83	2.56	27.21	2.65	26.43	2.73	26.00	2.78	25.65	2.82	24.72	2.90
20	19	28.44	2.61	27.81	2.69	27.01	2.78	26.57	2.83	26.22	2.86	25.26	2.95
25	23	29.05	2.65	28.41	2.74	27.59	2.82	27.14	2.87	26.78	2.91	25.81	3.00
30	28	29.82	2.70	29.15	2.79	28.32	2.88	27.86	2.93	27.49	2.97	26.49	3.06
35	32	30.43	2.74	29.75	2.83	28.90	2.92	28.43	2.97	28.05	3.01	27.03	3.11
40	36	31.04	2.78	30.35	2.88	29.48	2.97	29.00	3.02	28.61	3.06	27.57	3.15
45	41	31.81	2.84	31.10	2.93	30.21	3.03	29.71	3.08	29.32	3.12	28.25	3.21
47	43	32.11	2.86	31.40	2.95	30.50	3.05	<b>30</b>	<b>3.1</b>	29.60	3.14	28.52	3.24
50	46	32.21	2.84	31.56	2.93	30.78	3.01	30.33	3.06	29.97	3.09	28.96	3.18
55	51	32.36	2.81	31.83	2.88	31.24	2.95	30.88	2.98	30.59	3.01	29.69	3.07
60	56	32.52	2.78	32.10	2.83	31.70	2.89	31.43	2.91	31.22	2.93	30.42	2.97
63	59	32.62	2.76	32.26	2.81	31.98	2.85	31.76	2.86	31.59	2.88	30.85	2.91
68	64	32.71	2.74	32.42	2.78	32.26	2.81	32.10	2.82	31.96	2.83	31.30	2.85

TC = Total Capacity (kBtu/h).

PI = Power input (KW). Power input (KW) includes compressor and fan(s).

The shaded table rows indicate reference data. When operating at this temperature, these values can be different if the system is not running consistently.

Nominal capacity as rated 0 ft. above sea level and a 0 ft. level difference between outdoor and indoor unit. Corresponding refrigerant piping length is accordance with standard length of each outdoor unit.

Nominal heating capacity rating obtained with air entering the indoor unit at 70°F dry bulb (DB) and 60°F wet bulb (WB), and outdoor ambient conditions of 47°F dry bulb (DB) and 43°F wet bulb (WB).

# PERFORMANCE DATA

## High Static Ducted Maximum Heating Capacity Tables

### Maximum Heating Capacity Table for LH368HV4 (LHN368HV + LUU369HV)

Table 43: LH368HV4 Ceiling-Concealed Duct (High Static) System Max Heating Capacity Table.

Outdoor Air Temp.		Indoor Air Temperature: °F DB											
		61.0		64.0		68.0		70.0		72.0		75.0	
°F DB	°F WB	TC	PI	TC	PI	TC	PI	TC	PI	TC	PI	TC	PI
-13	-13.4	22.28	4.35	21.78	4.49	21.16	4.63	20.82	4.71	20.54	4.78	19.79	4.92
-4	-4.4	29.24	4.65	28.58	4.80	27.77	4.96	27.31	5.04	26.95	5.11	25.97	5.26
0	-0.4	32.89	4.83	32.16	4.99	31.24	5.15	30.73	5.24	30.32	5.31	29.22	5.47
5	4.5	37.47	5.05	36.63	5.22	35.58	5.39	35.00	5.48	34.53	5.55	33.28	5.72
10	9	40.45	4.96	39.54	5.12	38.41	5.28	37.79	5.38	37.28	5.45	35.93	5.61
17	15	44.42	4.89	43.43	5.05	42.19	5.21	41.50	5.30	40.95	5.37	39.46	5.53
20	19	44.53	4.65	43.53	4.80	42.29	4.96	41.60	5.04	41.05	5.11	39.55	5.26
25	23	44.64	4.41	43.64	4.56	42.39	4.70	41.70	4.79	41.15	4.85	39.65	5.00
30	28	44.77	4.12	43.77	4.25	42.52	4.39	41.83	4.46	41.27	4.52	39.77	4.66
35	32	44.88	3.88	43.88	4.01	42.62	4.14	41.93	4.21	41.37	4.26	39.86	4.39
40	36	44.98	3.64	43.98	3.76	42.72	3.88	42.03	3.95	41.47	4.00	39.96	4.12
45	41	45.12	3.35	44.11	3.46	42.85	3.57	42.15	3.63	41.59	3.68	40.08	3.79
47	43	45.17	3.23	44.16	3.33	42.90	3.44	<b>42.20</b>	<b>3.50</b>	41.64	3.55	40.13	3.65
50	46	45.30	3.21	44.39	3.30	43.29	3.40	42.66	3.45	42.16	3.49	40.74	3.58
55	51	45.53	3.17	44.77	3.25	43.94	3.33	43.44	3.37	43.04	3.40	41.76	3.47
60	56	45.75	3.14	45.15	3.20	44.60	3.26	44.21	3.28	43.91	3.30	42.79	3.35
63	59	45.88	3.12	45.38	3.17	44.99	3.22	44.68	3.23	44.43	3.25	43.40	3.28
68	64	46.01	3.10	45.61	3.14	45.38	3.18	45.15	3.18	44.96	3.19	44.02	3.22

TC = Total Capacity (kBtu/h).

PI = Power input (KW). Power input (KW) includes compressor and fan(s).

The shaded table rows indicate reference data. When operating at this temperature, these values can be different if the system is not running consistently.

Nominal capacity as rated 0 ft. above sea level and a 0 ft. level difference between outdoor and indoor unit. Corresponding refrigerant piping length is accordance with standard length of each outdoor unit.

Nominal heating capacity rating obtained with air entering the indoor unit at 70°F dry bulb (DB) and 60°F wet bulb (WB), and outdoor ambient conditions of 47°F dry bulb (DB) and 43°F wet bulb (WB).

# CEILING-CONCEALED DUCTED UNIT APPLICATION GUIDELINES

**Equipment Selection Procedure on page 66**

**Placement Considerations on page 68**

**Clearances on page 78**

**Installing Outdoor Unit Indoors on page 81**

**Refrigerant Piping Design on page 83**

# EQUIPMENT SELECTION PROCEDURE

## Cooling / Heating Correction Factors

For Ceiling-Concealed Ducted systems, calculate the equivalent length of the liquid line from the outdoor unit to the indoor unit. Also, determine the elevation difference of the indoor unit above or below the outdoor unit. Find corresponding cooling or heating capacity correction factors as shown below. Multiply the correction factors by the cooling or heating capacity obtained from the capacity table using design conditions. The result is the NET cooling or heating capacity.

### Refrigerant Line Length Derates

For air-cooled systems, a capacity correction factor may have to be applied to account for the length of the system's refrigerant pipe. Rate of change in capacity due to increased piping lengths is shown below.

Table 44: Low Static Ducted System Cooling and Heating Capacity Coefficient Factors.

Piping Length (ft.)		24.6	32.8	49.2	65.6	98.4	131.2	164.0	196.9	229.7	246.0
<i>Cooling Capacity Coefficient Factor</i>											
Rate of Capacity Change (%)	LD097HV4 (9,000)	100	99.7	99.2	98.7	-	-	-	-	-	-
	LD127HV4 (12,000)	100	99.7	99.2	98.7	-	-	-	-	-	-
	LD187HV4 (18,000)	100	100	99.3	97.9	96.6	93.8	91.1			
<i>Heating Capacity Coefficient Factor</i>											
Rate of Capacity Change (%)	LD097HV4 (9,000)	100	99.7	99.2	98.7	-	-	-	-	-	-
	LD127HV4 (12,000)	100	99.7	99.2	98.7	-	-	-	-	-	-
	LD187HV4 (18,000)	100	99.3	97.9	96.6	94.8	91.1	88.4			

Table 45: High Static Ducted System Cooling and Heating Capacity Coefficient Factors.

Piping Length (ft.)		24.6	32.8	49.2	65.6	98.4	131.2	164.0	196.9	229.7	246.0
<i>Cooling Capacity Coefficient Factor</i>											
Rate of Capacity Change (%)	LH248HV4 (24,000 Btu/h)	100	100	99.3	97.9	96.6	93.8	91.1	-	-	-
	LH368HV4 (36,000 Btu/h)	100	100	99.3	97.9	96.6	93.8	91.1	88.4	85.6	82.9
<i>Heating Capacity Coefficient Factor</i>											
Rate of Capacity Change (%)	LH248HV4 (24,000 Btu/h)	100	99.3	97.9	96.6	93.8	91.1	88.4	-	-	-
	LH368HV4 (36,000 Btu/h)	100	99.7	99.2	98.7	97.7	96.6	95.6	94.6	93.5	93.0

### Equivalent Piping Length for Piping Components

Table 46: Equivalent Piping Length for Elbows.

Component	Size (Inches)													
	1/4	3/8	1/2	5/8	3/4	7/8	1	1-1/8	1-1/4	1-3/8	1-1/2	1-5/8	1-3/4	2-1/8
Elbow (ft.)	0.5	0.6	0.7	0.8	1.2	1.3	1.5	1.6	1.8	2.0	2.1	2.3	2.5	2.8

### Altitude Correction Factor

The impact of air density must be considered on systems installed at a significant altitude above sea level, therefore, locally accepted altitude correction factors must be applied.

# EQUIPMENT SELECTION PROCEDURE

## Defrost Correction Factor for Heating Operation

The outdoor unit heating capacity may need to be adjusted for frost accumulation on air-cooled systems. If design day conditions are below the dewpoint of the surrounding air, frost may not be a problem and no correction factor is needed. In certain weather conditions, however, frost may form and accumulate on the air-cooled outdoor unit coil and impact the coils ability to transfer heat. If significant frost accumulates on the outdoor unit coil, a defrost algorithm will start automatically. The timing between defrost periods is determined by the system's ability to achieve a target head pressure value.

Capacity and AHRI ratings tables do not factor in capacity reduction when frost has accumulated on the condenser coil, nor during defrost operation.

Integrated heating capacity values can be obtained using the formula:

$$A = B \times C$$

Where:

A = Integrated Heating Capacity.

B = Value found in the Capacity Table.

C = Correction Factor for Frost Accumulation Factor (from Table 24).

Table 47: Outdoor Unit Frost Accumulation Factor (Heating)<sup>1</sup>.

Entering DB (°F)	19.4	23.0	26.6	32.0	37.4	41.0	44.6
Derate factor	0.98	0.95	0.93	0.86	0.93	0.96	1.0

<sup>1</sup>At 85% outdoor air relative humidity.

The frost accumulation factor does not account for effects of snow accumulation restricting airflow through the outdoor unit coil.

## Note:

There will be temporary reduction in capacity when frost / ice accumulates on the outside surface of the outdoor unit heat exchanger. The level of capacity reduction depends on a number of factors, for example, outdoor temperature (°F DB), relative humidity (RH), and the amount of frost present.

## Check the Indoor and Outdoor Unit Selection(s)

Compare the corrected cooling and heating capacities to the load calculations. Is each capacity sufficient for the zone it serves?

For each indoor unit, the corrected capacity must be at least equal to the total of the cooling design load (plus ventilation load, if applicable) for the space(s) served by the indoor unit. For each indoor unit, the corrected capacity also must be at least equal to the total of the heating design load (plus ventilation load, if applicable) for the space(s) and / or thermal zones served by the indoor unit.

The outdoor unit selected must be large enough to offset the total cooling load for all spaces it serves (account for ventilation air cooling load if the ventilation air has not been pretreated to room neutral conditions). The outdoor unit must also be large enough to offset the total heating load for all spaces it serves.

If the corrected heating capacity ratio exceeds 100%, reselect the equipment, or change the system design by moving some of the load to another system.

## System Sizing Check Formulas

### 1. Outdoor Unit Rated Capacity.

$Q_{odu(rated)}$  (From capacity tables).

### 2. Outdoor Unit Capacity at $T_i$ , $T_o$ Temperature.

$Q_{odu(T_i, T_o)}$  (From capacity tables).

### 3 Outdoor Unit Capacity Coefficient Factor.

$$F_{(T_i, T_o)} = Q_{odu(T_i, T_o)} / Q_{odu(rated)}$$

### 4. Piping Correction Factor (From Capacity Coefficient Factor Tables).

$F_{(length)}$  for each piping length

### 5. Individual Indoor Unit Combination Capacity.

$$Q_{idu( combi )} = Q_{odu(rated)} \times Q_{idu(rated)} / Q_{idu(rated-total)}$$

### 6. Individual Indoor Unit Actual Capacity.

$$Q_{idu( actual )} = Q_{odu( combi )} \times F_{(T_i, T_o)} \times F_{(length, altitude)}$$

## Conclusions and Recommendations

- Understand the design safety factors.
- Reference load calculations for actual cooling and heating capacities (applies in 99% of applications – consider total load when latent load is greater than 30%).
- Verify that the sensible load of the zone is satisfied.

- Use caution when sizing to meet listed capacity specifications for the scheduled manufacturer's equipment.
- If further system design assistance is needed, or you have a unique application you would like to discuss, contact your LG sales rep.

# PLACEMENT CONSIDERATIONS

## Indoor Unit

### Selecting the Best Location for the Indoor Unit

#### Note:

Follow recommended best practices when choosing an indoor location for the single zone indoor unit.

#### Dos

- Place the unit where air circulation will not be blocked.
- Locate the indoor unit in a location that is level, and where it can be easily connected to the outdoor unit.
- Place the unit where drainage can be obtained easily. Condensation drain must be conveniently routed away from the unit.
- Include enough space around the indoor unit so that it is accessible for maintenance and service purposes.
- Where electrical noise / electromagnetic waves will not affect indoor unit operation. Maintain proper distances between the indoor units and electric wires, audio and visual appliances, breaker / circuit panels, etc. If the frequency signal of the appliance is unstable, then install the indoor unit a minimum of ten (10) feet away, and run the power and transmission cables through a conduit.
- An area that is level and with enough strength to bear the weight of the indoor unit(s).

#### ⊘ Dont's

- Do not install the unit near a heat or steam source, or where considerable amounts of oil, iron powder, or flour are used. (These materials may generate condensate, cause a reduction in heat exchanger efficiency, or the drain to malfunction. If this is a potential problem, install a ventilation fan large enough to vent out these materials.)
- Ensure there are no obstacles to air circulation around the unit; keep proper distances from ceilings, doorways, floor, walls, etc.
- Avoid installing the unit near high-frequency generators or near any equipment that generates an electromagnetic field (minimum 3-1/3 feet away).

#### **⚠ WARNING**

The unit must not be installed where sulfuric acid and flammable or corrosive gases are generated, vented into, or stored. There is risk of fire, explosion, and physical injury or death.

**The unit may be damaged, may malfunction, and / or will not operate as designed if installed in any of the conditions listed.**

#### Note:

- ⊘ Indoor units (IDUs) must not be placed in an environment where the IDUs may be exposed to harmful volatile organic compounds (VOCs) or in environments where there is improper air make up or supply or inadequate ventilation. If there are concerns about VOCs in the environment where the IDUs are installed, proper air make up or supply and/ or adequate ventilation must be provided. Additionally, in buildings where IDUs will be exposed to VOCs consider a factory-applied epoxy coating to the fan coils for each IDU.
- If the unit is installed near a body of water, the installation parts are at risk of corroding. Appropriate anti-corrosion methods must be taken for the unit and all installation parts.

#### Installing in an Area Exposed to Unconditioned Air

In some installation applications, areas (floors, walls) in some rooms may be exposed to unconditioned air (room may be above or next to an unheated garage or storeroom). To countermeasure:

- Verify that carpet is or will be installed (carpet may increase the temperature by three [3] degrees).
- Add insulation between the floor joists.
- Install radiant heat or another type of heating system to the floor.

#### Installing in an Area with High Humidity Levels

If the environment is prone to humidity levels of 80% or more (near the ocean, lakes, etc.) or where steam could collect in the plenum:

- Install additional insulation to the indoor unit (glass wool insulation >13/32 inches thick).
- Install additional insulation to the refrigerant piping (insulation >13/16 inches thick).
- Seal all gaps between the indoor unit and the ceiling tiles (make the area air tight) so that humidity does not transfer from the plenum to the conditioned space. Also, add a ceiling grille for ventilation.

Figure 45: Installing Near a Heat or Steam Source.

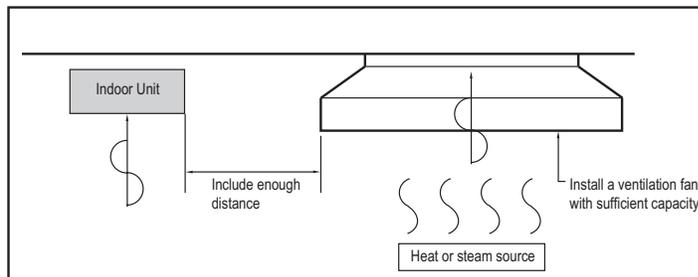

# PLACEMENT CONSIDERATIONS

## Indoor Unit

### Low Static Ducted IDU Service Space Required Dimensions, Bolt Locations

Figure 46: Low Static Ducted Indoor Unit General Service Space Required Dimensions and Bolt Locations

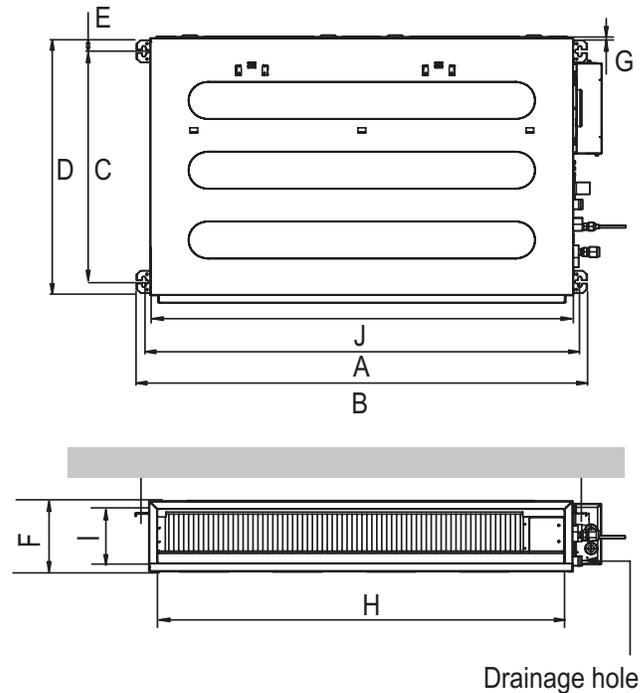
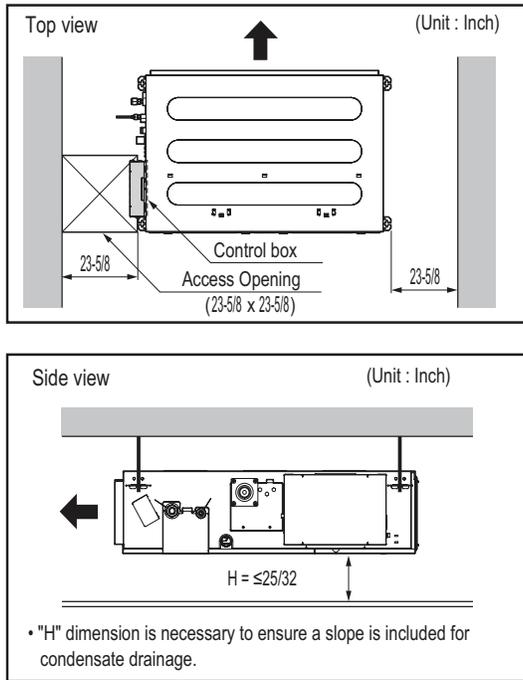

Table 48: Low Static Ducted Indoor Unit Bolt Location Dimensions.

Model / Capacity (Btu/h)	Dimensions (in.)									
	A	B	C	D	E	F	G	H	I	J
LDN097HV4 / 9,000	28-27/32	30-13/32	24-23/32	27-9/16	1-13/32	7-15/32	25/32	25-31/32	6-3/32	27-9/16
LDN127HV4 / 12,000	36-23/32	38-9/32						33-27/32		35-7/16
LDN187HV4 / 18,000										

Figure 47: Low Static Ducted IDU Access Panel Required Dimensions.

Table 49: Low Static Ducted Indoor Unit Access Panel Required Dimensions.

Model / Capacity (Btu/h)	Dimensions (in.)	
	A	B
LDN097HV4 / 9,000	31-1/2	31-1/2
LDN127HV4 / 12,000		39-3/8
LDN187HV4 / 18,000		

Refer to figure 46 on the right.

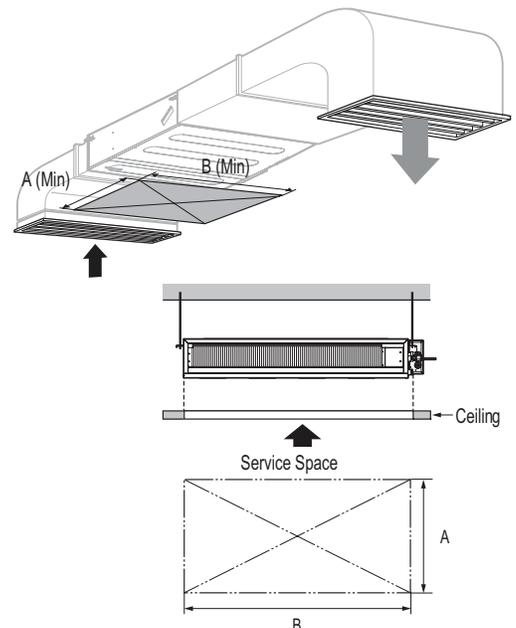

# PLACEMENT CONSIDERATIONS

## Indoor Unit

### High Static Ducted IDU Service Space Required Dimensions, Bolt Locations

Figure 48: High Static Ducted Indoor Unit Bolt Locations.

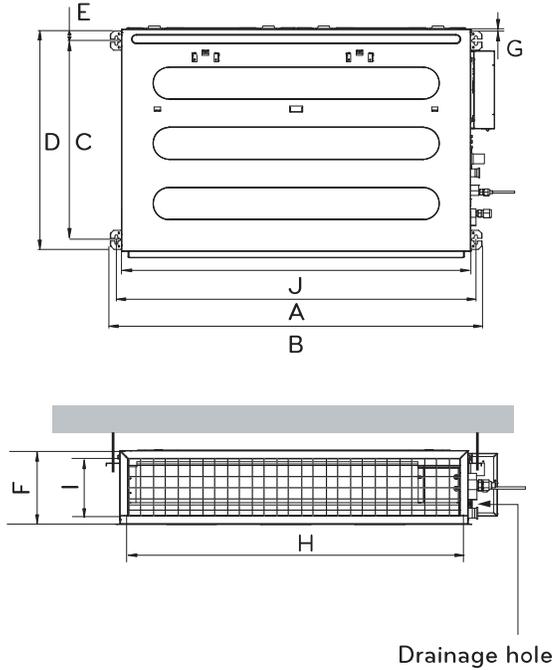

Table 50: High Static Ducted Indoor Unit Bolt Location Dimensions.

Model / Capacity (Btu/h)	Dimensions (inches)									
	A	B	C	D	E	F	G	H	I	J
LHN248HV / 24,000	36-3/4	38-1/4	24-3/8	27-9/16	1-3/16	10-5/8	19/32	33-25/32	7-15/16	35-7/16
LHN368HV / 36,000	50-17/32	52-1/32	24-3/8	27-9/16	1-3/16	10-5/8	19/32	47-9/16	7-15/16	49-7/32

Figure 49: High Static Ducted IDU Access Panel Required Dimensions.

Table 51: High Static Ducted Indoor Unit Bolt Location Dimensions.

Model / Capacity (Btu/h)	Dimensions (in.)	
	A	B
LHN248HV	31-1/2	39-3/4
LHN368HV	31-1/2	53-1/2

Refer to figure 48 on the right.

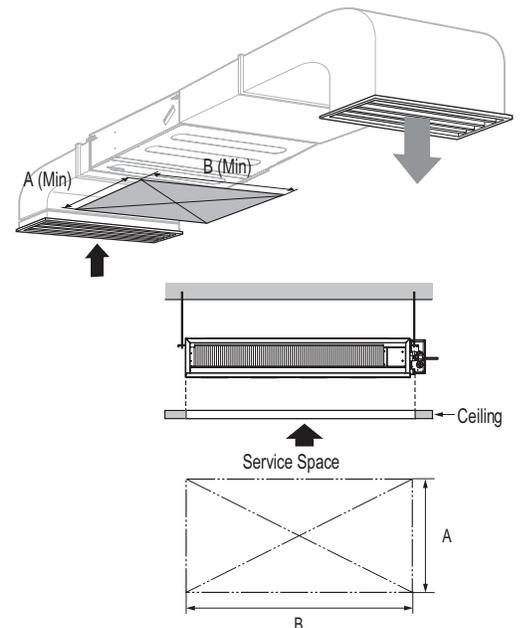

# PLACEMENT CONSIDERATIONS

## Indoor Unit

### Indoor Unit Drain System

- Drain piping must have downward gradient of at least 1/50 to 1/100; ⚠ to prevent reverse flow, slope must not be straight up and down.
- ⚠ Do not damage the drain port on the indoor unit when connecting the field-supplied drain piping.
- Drain piping specifications:
  - Indoor Unit Drain Connection: 1-1/4 inch outside diameter.
  - Field-Supplied Drain Piping: Polyvinyl chloride piping with 1-inch inside diameter and pipe fittings.

Figure 51: Drain Piping Installation Dimensions.

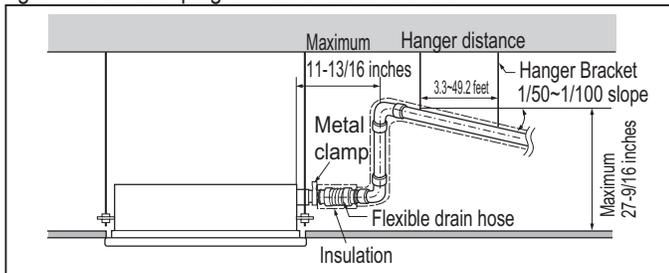

### Note:

Indoor unit appearances may vary depending on the model.

Figure 50: Indoor Unit Drain Piping.

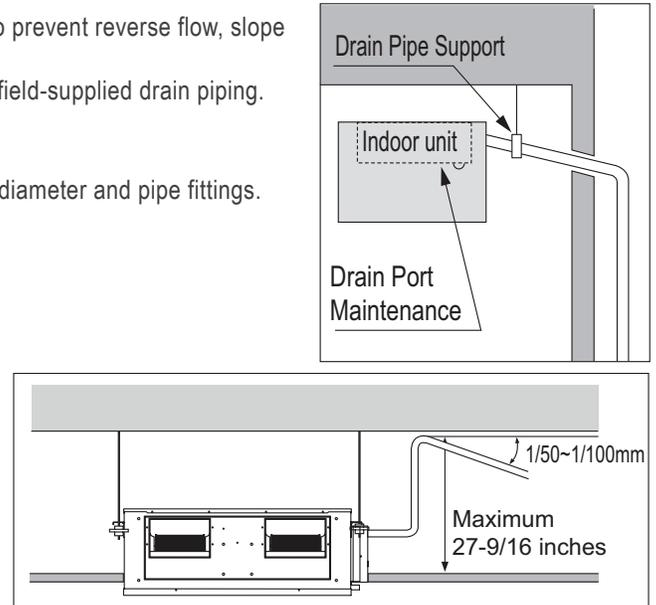

# PLACEMENT CONSIDERATIONS

## Outdoor Unit

### Selecting the Best Location for the Outdoor Unit

#### **⚠ DANGER**

- ⊘ Do not install the unit in an area where combustible gas may generate, flow, stagnate, or leak. These conditions can cause a fire, resulting in bodily injury or death.
- ⊘ Do not install the unit in a location where acidic solution and spray (sulfur) are often used as it can cause bodily injury or death.
- ⊘ Do not use the unit in environments where oil, steam, or sulfuric gas are present as it can cause bodily injury or death.

#### **⚠ WARNING**

When deciding on a location to place the outdoor unit, be sure to choose an area where run-off from defrost will not accumulate and freeze on sidewalks or driveways, which may create unsafe conditions. Properly install and insulate any drain hoses to prevent the hose from freezing, cracking, leaking, and causing unsafe conditions from frozen condensate.

Install a fence to prevent vermin from crawling into the unit or unauthorized individuals from accessing it. Follow the placement guidelines set forth in "Clearance Requirements".

Select a location for installing the outdoor unit that will meet the following conditions:

- Where there is enough strength to bear the weight of the outdoor unit.
- A location that allows for optimum air flow and is easily accessible for inspection, maintenance, and service.
- Where piping between the outdoor unit and indoor unit(s) are within allowable limits.
- Include space for drainage to ensure condensate flows properly out of the unit when it is in heating mode. Avoid placing the outdoor unit in a low-lying area where water could accumulate.
- If the outdoor unit is installed in a highly humid environment (near an ocean, lake, etc.), ensure that the site is well-ventilated and has a lot of natural light (Example: Install on a rooftop).



#### **Don'ts**

- Where it will be subjected to direct thermal radiation from other heat sources, or an area that would expose the outdoor unit to heat or steam like discharge from boiler stacks, chimneys, steam relief ports, other air conditioning units, kitchen vents, plumbing vents, and other sources of extreme temperatures.
- Where high-frequency electrical noise / electromagnetic waves will not affect operation.
- Where operating sound from the unit will disturb inhabitants of surrounding buildings.
- Where the unit will be exposed to direct, strong winds.
- Where the discharge of one outdoor unit will blow into the inlet side of an adjacent unit (when installing multiple outdoor units).

#### **Note:**

The indoor unit may take longer to provide heat, or heating performance will be reduced in winter if the unit is installed:

1. In a narrow, shady location.
2. Near a location that has a lot of ground moisture.
3. In a highly humid environment.
4. In an area in which condensate does not drain properly.

# PLACEMENT CONSIDERATIONS

## Outdoor Unit

---

---

### Outdoor Unit Condensate Drain Piping

Outdoor unit requires condensate drain piping. Condensate drain pipe is constructed with materials approved by local code. See Placement Considerations for information in reference to outdoor unit placement.

### Planning for Snow and Ice

To ensure the outdoor unit operates properly, certain measures are required in locations where there is a possibility of heavy snowfall or severe windchill or cold:

1. Prepare for severe winter wind chills and heavy snowfall, even in areas of the country where these are unusual phenomena.
2. Position the outdoor unit so that its airflow fans are not buried by direct, heavy snowfall. If snow piles up and blocks the airflow, the system may malfunction.
3. Remove any snow that has accumulated four (4) inches or more on the top of the outdoor unit.
4. In climates that may experience significant snow buildup, mount the outdoor unit on a raised, field-provided platform or stand. The raised support platform must be high enough to allow the unit to remain above possible snow drifts, and must be higher than the maximum anticipated snowfall for the location.
5. Design the mounting base to prevent snow accumulation on the platform in front or back of the unit frame.
6. Provide a field fabricated snow protection hood to keep snow and ice and/or drifting snow from accumulating on the coil surfaces.
7. Install a hail guard kit and air guide accessories (sold separately) to prevent snow or rain from accumulating on the fan inlet / outlet guards.
8. Consider tie-down requirements in case of high winds or where required by local codes.

#### **⚠ CAUTION**

*When deciding on a location to place the outdoor unit, be sure to choose an area where run-off from defrost will not accumulate and freeze on sidewalks or driveways, which may create unsafe conditions.*

#### **Note:**

*Choose an area where run-off from defrost mode will not accumulate and freeze on sidewalks or driveways. Properly install and insulate any drain hoses to prevent the hose from freezing, cracking, leaking, and damaging the outdoor unit.*

# PLACEMENT CONSIDERATIONS

## Outdoor Unit

### Underground Refrigerant Piping

Refrigerant pipe installed underground must be routed inside a vapor tight protective sleeve to prevent insulation deterioration and water infiltration. Refrigerant pipe installed inside underground casing must be continuous without any joints. Underground refrigerant pipe must be located at a level **below the frost line**.

Table 53: Utility Conduit Sizes (Inches).

Liquid Pipe <sup>1</sup>	Vapor Pipe <sup>1</sup>		
	3/8 (1-1/8 <sup>2,3</sup> )	1/2 (2.0 <sup>2,4</sup> )	5/8 (2-1/8 <sup>2,4</sup> )
1/4 (1.0) <sup>4</sup>	4	4	4
3/8 (1-1/8) <sup>4</sup>	4	4	4

<sup>1</sup>OD pipe diameter in inches; Values in parenthesis ( ) indicate OD of pipe with insulation jacket.

<sup>2</sup>Diameter of pipe with insulation. Thickness of pipe insulation is typical. Actual required thickness may vary based on surrounding ambient conditions and must be calculated and specified by the design engineer.

<sup>3</sup>Insulation thickness (value in parenthesis) = 3/8 inch.

<sup>4</sup>Insulation thickness (value in parenthesis) = 3/4 inch.

Figure 53: Typical Arrangement of Refrigerant Pipe and Cable(s) in a Utility Conduit.

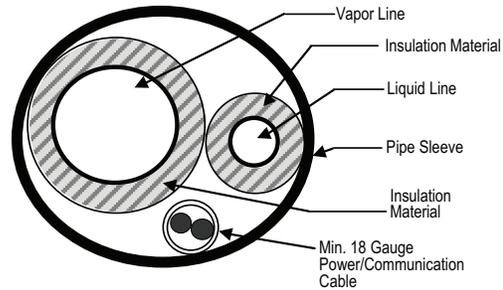

Table 54: Outdoor Unit Refrigerant Pipe Connections (All Brazed Type).

Model	Liquid Conn. (inches)	Vapor Conn. (inches)
LD097HV4, LD127HV4	1/4	3/8
LD187HV4	1/4	1/2
LH248HV4, LH368HV4	3/8	5/8

### Tie-Downs, Wind Restraints, and Lightning Protection

#### Tie-Downs

- The strength of the roof must be checked before installing the outdoor units.
- If the installation site is prone to high winds or earthquakes, when installing on the wall or roof, securely anchor the mounting base using a field-provided tie-down configuration approved by a local professional engineer.
- The overall tie-down configuration must be approved by a local professional engineer. Always refer to local code when using a wind restraint system.

#### Note:

Always refer to local code when designing a wind restraint system.

#### Lightning Protection

- To protect the outdoor unit from lightning, place the unit within the specified lightning safety zone.

Table 52: Safety Zone Specifications.

Building Height (feet)	66	98	148	197
Protection Angle (°)	55	45	35	25

- Power cable and communication cable must be installed five (5) feet away from lightning rod.
- A high-resistance ground system must be included to protect against induced lightning or indirect strike.

Figure 52: Lightning Protection Diagram.

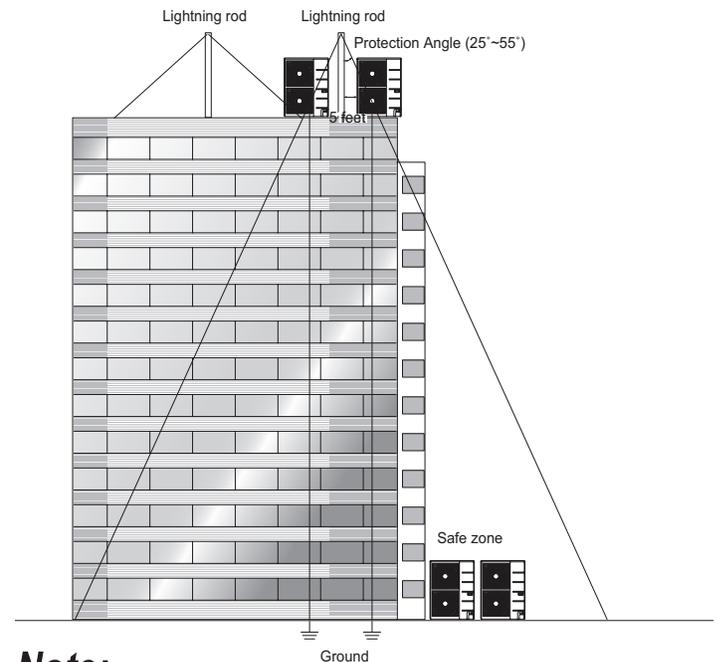

#### Note:

If the building does not include lightning protection, the outdoor unit may be damaged from a lightning strike. Inform the customer of this possibility in advance.

# PLACEMENT CONSIDERATIONS

## Outdoor Unit

### Oceanside Applications

#### Wind Protection

If the outdoor unit is placed on a roof, position it with the compressor end (no coil surface) in the direction of the prevailing wind as shown in the figure at right. In cooler climates, it may be beneficial to position the unit in direct sunlight to assist with defrost operations.

If the outdoor unit is not placed on a roof, place it on the leeward side of the building or in a location where the unit will not be exposed to constant wind.

If placement exposes the unit to constant wind activity, construct a wind break in front of the unit. Follow the placement guidelines set forth in "Clearance Requirements".

#### Tie-Downs and Wind Restraints

The strength of the Vertical Air Handling Unit frames is adequate to be used with field-provided wind restraint tie-downs. The overall tie-down configuration must be approved by a local professional engineer. Always refer to local code when designing a wind restraint system.

#### Mounting Platform

The underlying structure or foundation must be designed to support the weight of the unit. Avoid placing the unit in a low lying area where water may accumulate.

#### Oceanside Installation Precautions

##### Note:

*Ocean winds may cause corrosion, particularly on the condenser and evaporator fins, which, in turn could cause product malfunction or inefficient performance.*

- Avoid installing the outdoor unit where it would be directly exposed to ocean winds.
- Install the outdoor unit on the side of the building opposite from direct ocean winds.
- Select a location with good drainage.
- Periodically clean dust or salt particles off of the heat exchanger with water.

If the outdoor unit must be placed in a location where it would be subjected to direct ocean winds, install a concrete windbreaker strong enough to block any winds. Windbreaker height and width must be more than 150% of the outdoor unit, and be installed at least 27-1/2 inches away from the outdoor unit to allow for airflow.

Figure 54: Prevailing Wind Direction.

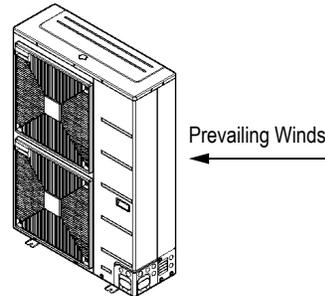

Figure 55: Leeward Side of the Building.



Figure 56: Wind Break.

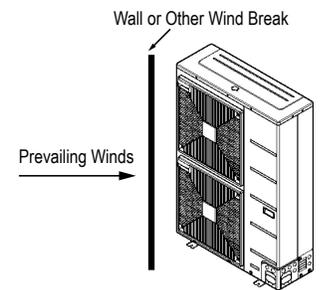
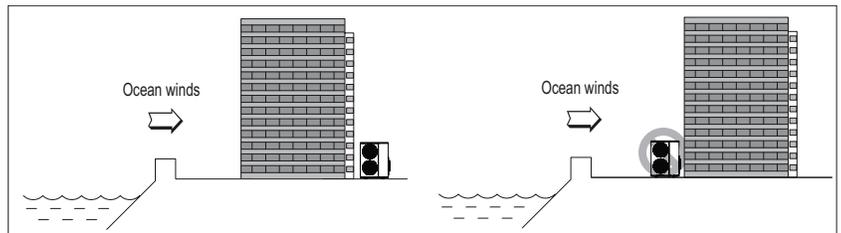
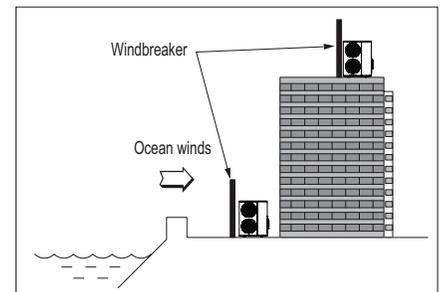

Figure 57: Oceanside Placement Using a Building as Shield, and Placement Using a Windbreaker.



##### Note:

*Additional anti-corrosion treatment may need to be applied to the outdoor unit at oceanside locations.*



# PLACEMENT CONSIDERATIONS

## Outdoor Unit

### General Mounting

Securely attach the outdoor unit to a condenser pad, base rails, or other mounting platform that is securely anchored to the ground or building structure. The underlying structure or foundation must be designed to support the weight of the unit, and avoid placing the outdoor unit in a low lying area where water may accumulate.

### Attaching the Outdoor Unit to the Bracket

When installing the outdoor unit on a wall or roof top, anchor the mounting base securely using nails or wire with regard to wind and earthquake or vibration.

Refer to installation manual, and follow the applicable local code for clearance, mounting, anchor, and vibration attenuation requirements.

### Note:

- All referenced materials are to be field-supplied.
- Images are not to scale.

Figure 58: Bracket Mounting.

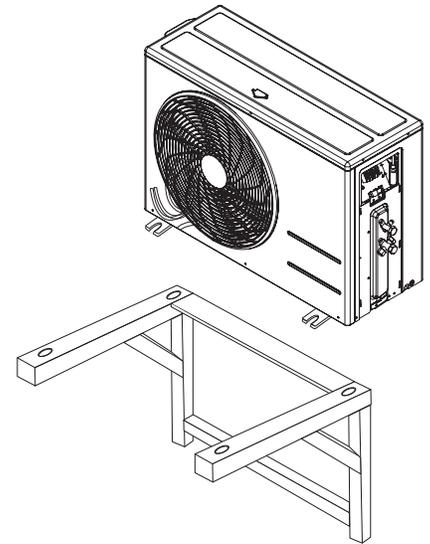

### Bolting the Outdoor Unit to the Platform

Figure 60: Bolting the LUU097HV and LUU127HV Outdoor Units to the Platform (Appearance May Vary).

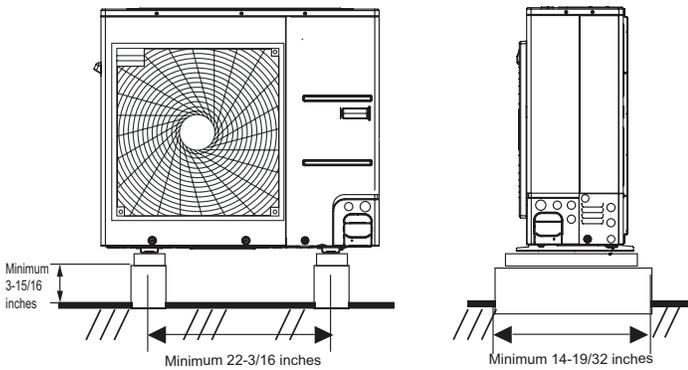

Figure 59: Bolting the LUU189HV AND LUU249HV Outdoor Units to the Platform (Appearance May Vary).

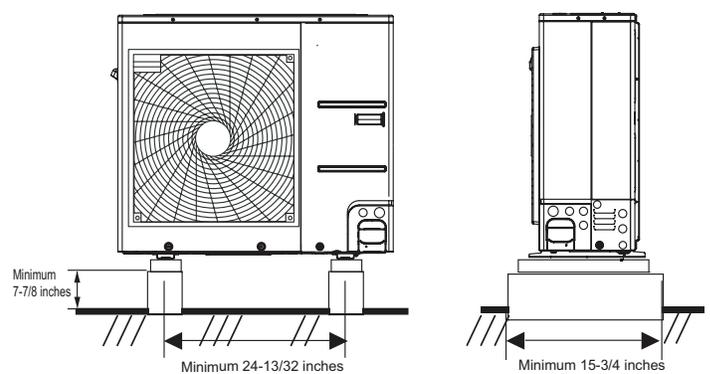

Table 55: Outdoor Unit Foundation Specifications.

Outdoor Unit	Bolt Type	Concrete Height	Bolt Depth
LUU097HV LUU127HV	M10-J	Minimum 3-15/16 inches	Minimum 2-3/8 inches
LUU189HV LUU249HV	M10-J	Minimum 7-7/8 inches	
LUU369HV	M10-J	Minimum 7-7/8 inches	

# PLACEMENT CONSIDERATIONS

## Outdoor Unit

### Bolting the Outdoor Unit to the Platform Procedure

When installing the outdoor unit onto a concrete or rigid mount, use a bolt and nut.

1. Ensure that the concrete platform will not degrade easily, and has enough strength to bear the weight of the unit.
2. Include an H-beam support. Firmly attach the corners, otherwise the support will bend.
3. Use a hexagon nut.
4. Use anti-vibration material.
5. Include enough space around the concrete foundation for condensate drainage.
6. Seal all wiring and piping access holes to prevent bugs from entering the unit.

### Concrete Platform Specifications

- Concrete foundations must be made of one part cement, two parts sand, and four parts gravel.
- The surface of the foundation must be finished with mortar with rounded edges, and weatherproofed.

### Note:

- All referenced materials are to be field-supplied.
- Images are not to scale.

Figure 61: Bolting the LUU369HV Outdoor Unit to the Platform.

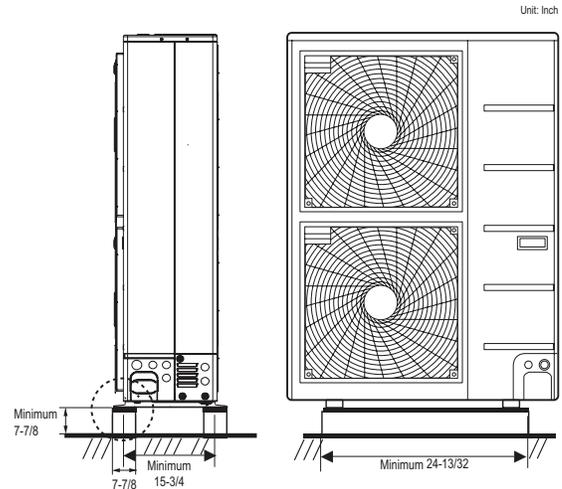

Figure 62: Platform Mounting.

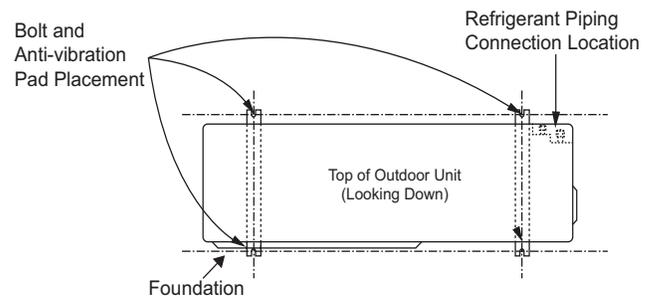
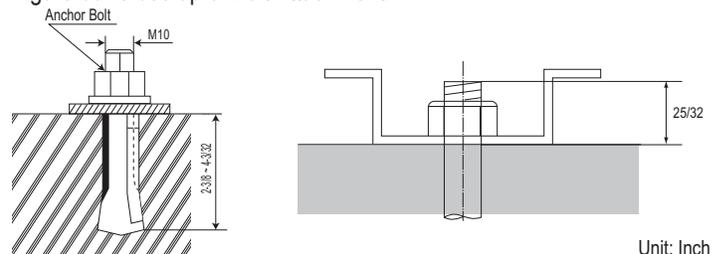

Figure 63: Close up of Bolt Attachment.



# CLEARANCES

## Outdoor Unit

### Minimum Allowable Clearance and Service Access Requirements

Proper clearance for the outdoor unit coil is critical for proper unit operation. When installing the outdoor unit, consider service, inlet and outlet and minimum allowable space requirements as illustrated in the diagrams on the following pages.

- Include enough space for airflow and for service access. If installing multiple outdoor units, avoid placing the units where the discharge of one unit will blow into the inlet side of an adjacent unit.
- If an awning is built over the unit to prevent direct sunlight or rain exposure, make sure that the discharge air of the outdoor unit isn't restricted.
- ⚠ No obstacles to air circulation around the unit; keep proper distances from ceilings, fences, floor, walls, etc. (Install a fence to prevent pests from damaging the unit or unauthorized individuals from accessing it.)

### Outdoor Unit (9,000 to 24,000 Capacity) Service Access and Allowable Clearances

Specific clearance requirements in the diagram below are for (9,000 to 24,000 Btu/h capacities). The figure below shows the overall minimum clearances that must be observed for safe operation and adequate airflow around the outdoor unit.

When placing the outdoor unit under an overhang, awning, sunroof or other "roof-like structure", observe the clearance requirements (as shown in Cases 1 and 2) for height in relation to the unit. To have successful service access to the outdoor unit, see the figure below for minimum spacing. When installing multiple outdoor units, see Cases 4 and 5 for correct spacing requirements.

Figure 64: 9,000 to 24,000 Capacity Outdoor Unit Service Access and Allowable Clearances Diagram.

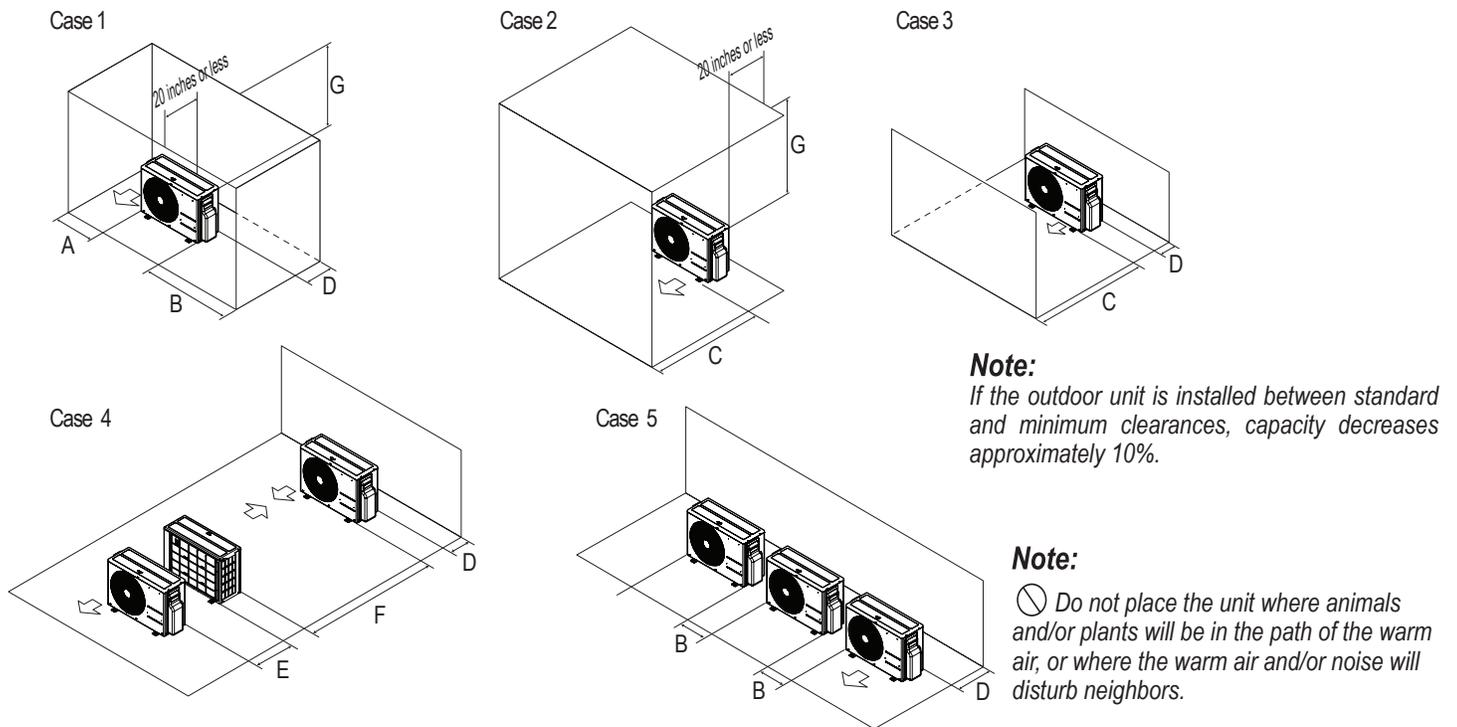

Table 56: 9,000 to 24,000 Outdoor Unit Service Access and Allowable Clearances Diagram Legend.

Unit: Inch		A	B	C	D	E	F	G
Case 1	Standard	12	24	-	12	-	-	-
	Minimum	4	10	-	4	-	-	40
Case 2	Standard	-	-	20	-	-	-	-
	Minimum	-	-	14	-	-	-	40
Case 3	Standard	-	-	20	12	-	-	-
	Minimum	-	-	14	4	-	-	-
Case 4	Standard	-	-	-	12	24	-	-
	Minimum	-	-	-	4	8	79	-
Case 5	Standard	-	24	-	12	-	-	-
	Minimum	-	10	-	4	-	-	-

# CLEARANCES

## Outdoor Unit

### Outdoor Unit (36,000 Btu/h Capacity) Service Access and Allowable Clearances

When installing the outdoor unit, consider service, inlet, and outlet, and minimum allowable space requirements as illustrated in the following diagrams.

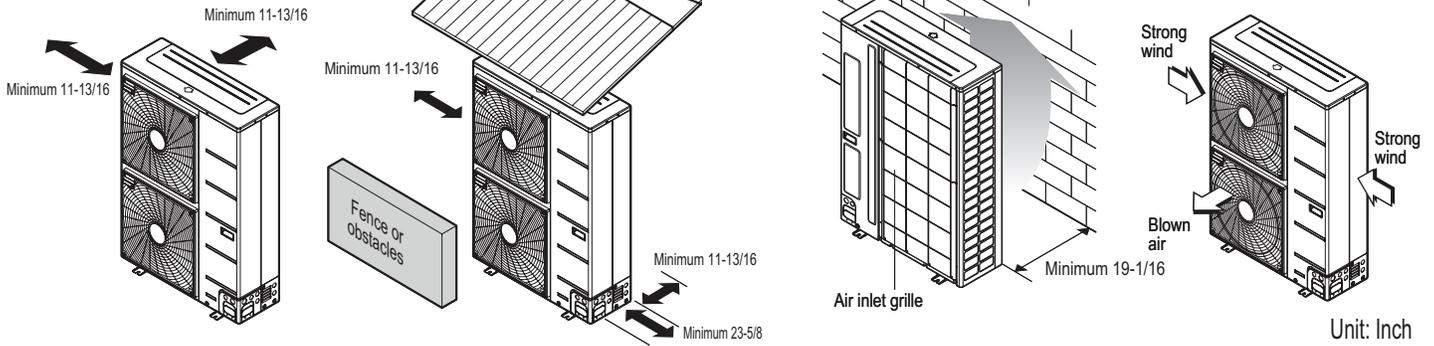

Ensure that the space at the back of the outdoor unit is a minimum of 11-13/16 inches, and include a minimum of 23-5/8 inches at the right side of the unit for service.

If the outdoor unit discharge side faces a wall, include a minimum of 19-11/16 inches between the outdoor unit and the wall. Install the outdoor unit so that the discharge port is set at a right angle to the wind direction.

Clearance Requirements when Different Obstacles are Present (Unit: Inch).

#### Obstacle on the suction side only.

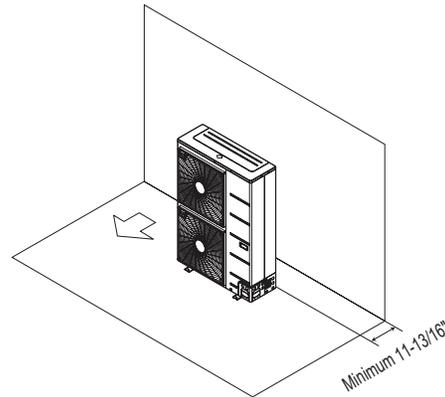

#### Obstacles on the suction side and on both left and right sides.

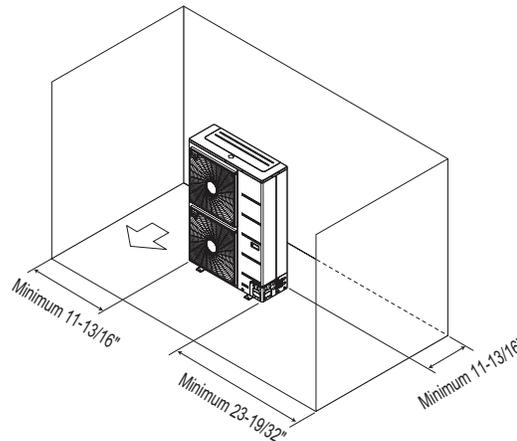

#### Obstacles above and on the air intake side.

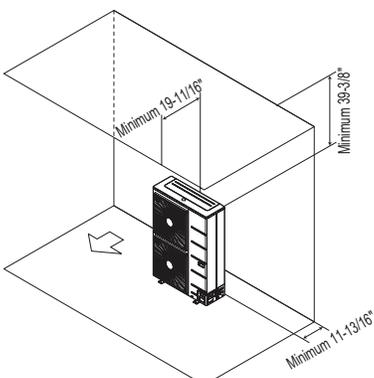

#### Obstacles above, on the air intake side, and on both left and right sides.

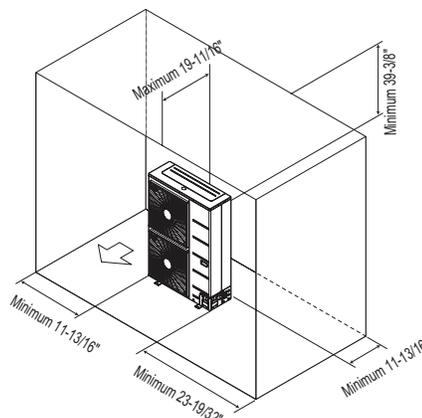

# CLEARANCES

## Outdoor Unit

Obstacle just on the air discharge side.

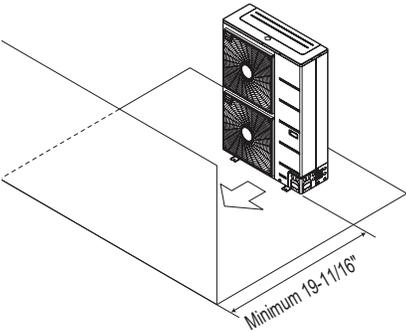

Obstacles above and on the air discharge side.

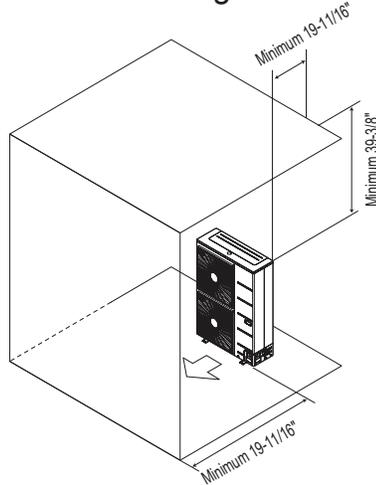

Where there are obstacles on both suction and discharge sides (discharge side obstacle is higher than the outdoor unit).

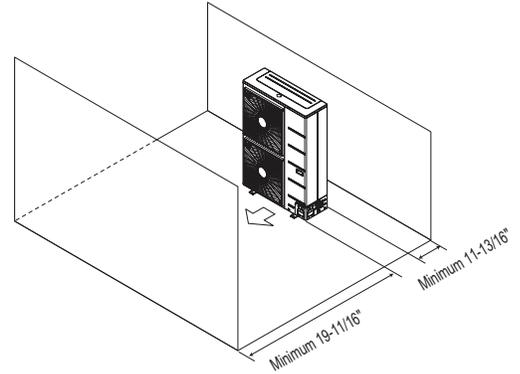

Where there are obstacles above, and on both suction and discharge sides (discharge side obstacle is higher than the outdoor unit).

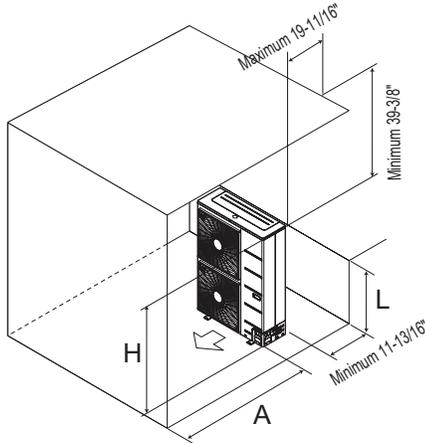
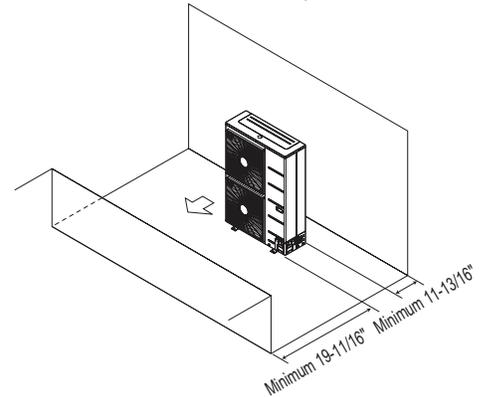

Table 57: Ratio among H, A, and L.

	L	A
$L \leq H$	$0 < L \leq 1/2 H$	29-1/32 inches
	$1/2 H < L$	39-3/8 inches
$H < L$	Set Stand as: $L \leq H$	

If a stand is necessary, it must be contained (not open frame) to prevent the discharge air from short cycling.

Where there are obstacles on both suction and discharge sides (discharge side obstacle is lower than the outdoor unit).



Where there are obstacles above, and on both suction and discharge sides (discharge side obstacle is lower than the outdoor unit).

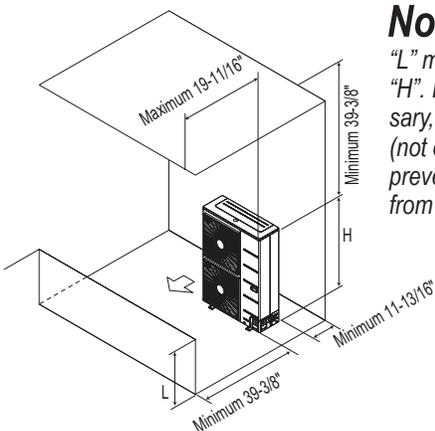

### Note:

"L" must be lower than "H". If a stand is necessary, it must be contained (not open frame) to prevent the discharge air from short cycling.

Series installation

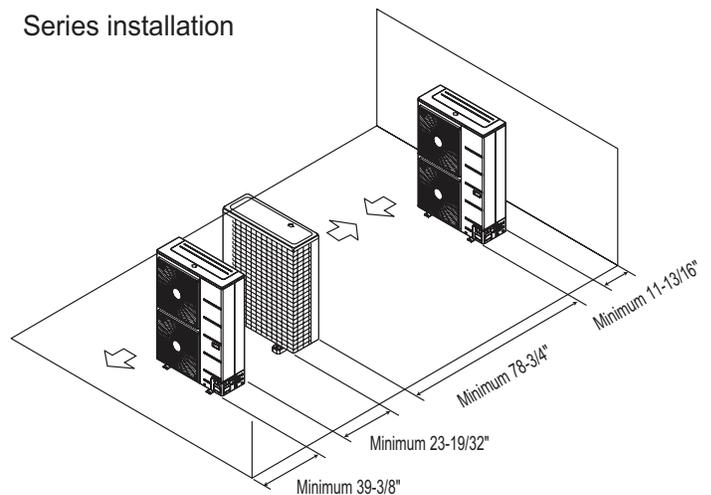

# INSTALLING OUTDOOR UNITS INDOORS

## Installing Outdoor Units Indoors

LG outdoor units are engineered to be mounted outdoors and include technology designed to minimize the negative effects of winter weather's freezing rain, sleet, and snow. Some building projects, however, necessitate placing the HVAC outdoor units indoors:

- Lack of ground space.
- Lack of an appropriate outdoor location that meets system design requirements.
- When mounting on the roof is not an option due to a lack of roof space.
- Roof warranty will be voided if mechanical equipment is placed on the membrane.
- On retrofit projects, a former chiller / boiler / air handler equipment room, mechanical area, or penthouse already exists.
- Where a project has vertical, self-contained VAV air handlers on each floor (in lieu of a centralized mechanical room).
- To curtail the potential need for redundant zone heating devices such as wall-fin radiators or duct heaters.
- In extremely cold environments where there is a significant amount of run-time at temperatures well below freezing outside the outdoor unit ambient air temperature range published in this engineering manual.

## Benefits of Installing Outdoor Units Indoors

- Shelters the outdoor unit from direct exposure to prevailing winds that decrease the heating capability of the outdoor unit.
- Protects equipment from freezing precipitation and / or potential ice build-up that could hinder unit operation.
- Maintains coil heat transfer efficiency by reducing the number of and shortening the cycle time for defrost operation.
- Easier maintenance and servicing during inclement weather.
- When mounted in a fully enclosed space, limiting the ambient air temperature may allow the system designer to eliminate oversizing the outdoor unit to compensate for loss of capacity at low ambient temperatures.
- May also curtail the need to provide inefficient redundant zone heating devices such as wall-fin radiators and second-stage ancillary heating devices.

## Design Considerations Include:

- Enclosure types and elements such as louvers, rain hoods, dampers and controls, heating methods and sizing of heating devices
- Heating strategies
- Duct design
- Condensate handling

## General Guidelines

- Follow ASHRAE 62.1 design guidelines.
- Depending on the project / application, a roof over the outdoor units in combination with a wind break may be all that is necessary.
- Consider the potential for snow accumulation near louvers / roof openings. Outside air intakes and discharge ducts/louvers must be engineered to clear anticipated snow accumulation levels by at least one (1) foot.
- In situations where operation is anticipated at temperatures of -13°F and lower, ancillary heat must be provided to heat the outdoor unit coils to assure continuous compressor operation and heating.

It may be necessary to use an air guide accessory to prevent discharge air from short-cycling back to the coil inlet.

- Another option is to field manufacture ductwork and mount on top of the unit to encompass the outdoor unit fan discharge and connect to the exterior discharge grille on the building.
- Avoid using a single duct on multi-fan units to prevent short cycling. Provide a dedicated duct for each outdoor unit fan discharge.
- Consider the direction of prevailing winds and opening placement. If possible, locate inlet openings upwind of discharge openings and other exhaust outlets.
- When inlet and outlet openings are placed on the same wall, minimum distance between the two openings must be approximately three (3) feet (minimum distance varies significantly with variations in outlet opening face velocity).
- If roof-mounted ventilation openings are used, strategically locate the inlet ventilation opening(s) upwind of the outlet opening(s).
- Discharge and supply ductwork must be designed to avoid weather related long periods of water entrainment and the potential for microbial growth.

# INSTALLING OUTDOOR UNITS INDOORS

---

---

Provide a means to drain the condensate generated during heating mode and defrost cycle in addition to rainwater that infiltrates the inlet louver enclosed area.

- Install a field-provided drain pan under the outdoor units and provide a path to a nearby floor drain.
- If the ambient air temperature is expected to drop below 32°F in the enclosure, heat the bottom surface of the pan, drain line, and floor drain so that the condensate does not freeze before reaching the drain.

Allow for ventilation intake and exhaust air based on maximum outdoor unit fan capacity.

- Select the size, type and orientation of architectural louvers with adequate "net free area" face velocity to ensure the total external static pressure from the outdoor unit fan does not exceed design limitations (see specification data tables).
-  No obstructions must be placed in front of the louver that could hamper the free flow (throw) of air.
- Roof top openings and / or discharge and supply louvers must be equipped with screens to prevent bird and insect infiltration.

As always, the best solution for each project balances acceptable heating performance (considering local weather conditions), capital costs, life cycle energy consumption, and limitations set forth by local building codes.

# REFRIGERANT PIPING DESIGN

## Design Guideline Summary

### Device Connection Limitations

A single-zone ceiling-concealed ducted system consists of one outdoor unit and one indoor unit. One of the most critical elements of a single-zone ceiling-concealed ducted system is the refrigerant piping. The table below lists pipe length limits that must be followed in the design of a single-zone ceiling-concealed ducted refrigerant pipe system:

Table 58: Single-Zone Ceiling-Concealed Ducted Refrigerant Piping System Limitations.

System Model Name		LD097HV4, LD127HV4	LD187HV4, LH248HV4	LH368HV4
Pipe Length (ELF = Equivalent Length of Pipe)	Longest total equivalent piping length	66 feet	164 feet	246 feet
	Shortest total equivalent piping length	6.6	6.6	6.6
	Distance between fittings and indoor or outdoor units	≥20 inches	≥20 inches	≥20 inches
	No additional refrigerant	25 feet	25 feet	25 feet
Elevation (All Elevation Limitations are Measured in Actual Feet)	If outdoor unit is above indoor unit	49 feet	98 feet	98 feet
	If outdoor unit is below indoor unit	49 feet	98 feet	98 feet
Additional Refrigerant Needed (oz/ft)		0.22	0.43	0.43

### System Layout

Figure 65: Typical LD097HV4, LD127HV4 System Layout.

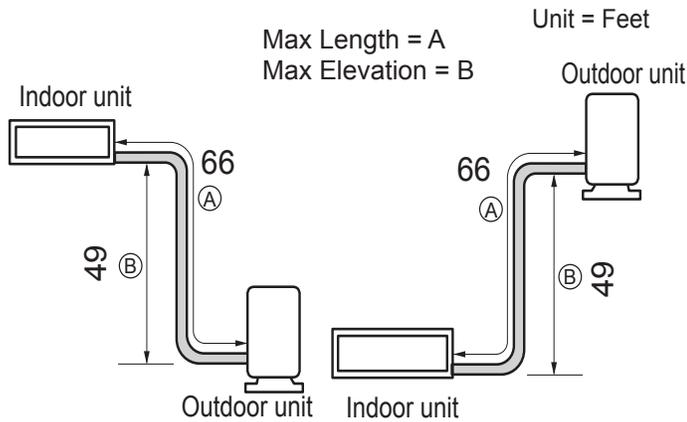

Figure 66: Typical LD187HV4, LH248HV4 System Layout.

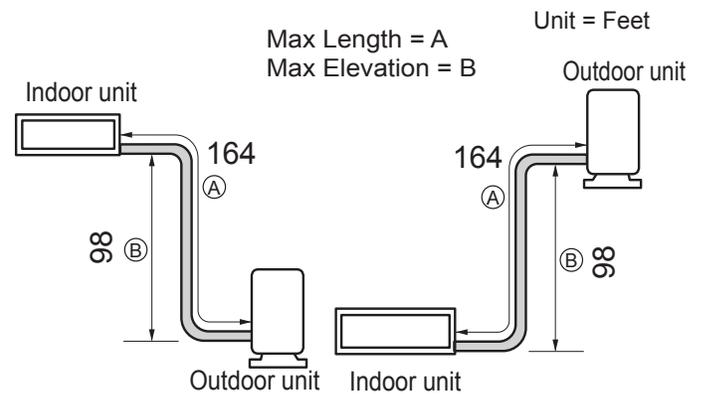
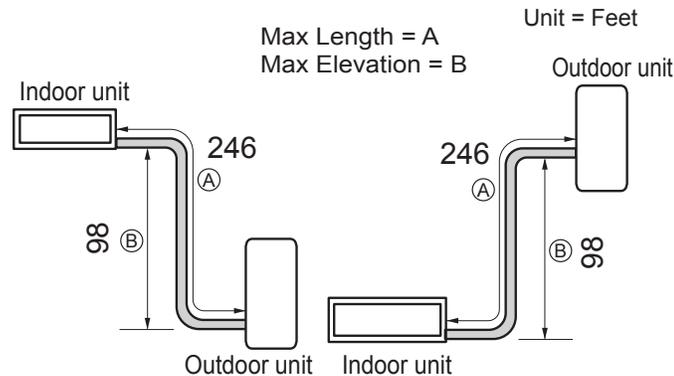

Figure 67: Typical LH368HV4 System Layout.



*Inverter*



LG Electronics, U.S.A., Inc.  
Air Conditioning Technologies  
4300 North Point Parkway  
Alpharetta, Georgia 30022  
[www.lghvac.com](http://www.lghvac.com)

EM\_SZ\_Ducted\_07\_21  
Supersedes: EM\_SZ\_Ducted\_09\_19  
EM\_SZ\_Ducted\_12\_18  
EM\_SZ\_Ducted\_11\_18  
EM\_SZ\_Ducted\_8\_17  
EM\_SZ\_Ducted\_5\_16  
DFS-EM-AM-001-US\_014D02