

# LCH0060LCACZA0300 - SUBMITTAL



Project Name:		Project Location:	
Quote ID:		Item #:	1000
Submitted For:		Submitted On:	
Submitted By:		Submitted From:	
Identity #:		Tag:	

For Record       For Approval      By: \_\_\_\_\_      Date: \_\_\_\_\_

## General Product Information

Product Family:	LCH	Compressor Brand:	Copeland
Application:	Outdoor	Compressor Type:	Scroll
Temperature Range:	Low Temp	Compressor Hp:	6
Voltage: (Volts/Ph/Hz)	208-230/3/60	Compressor Model:	ZF18K4E-TF5-251
Refrigerant Type:	R404A	Number of Compressor(s):	1
Piping:	Standard	Coil Type:	Microchannel

NOTE : THIS EQUIPMENT IS PROHIBITED FROM USE IN CALIFORNIA WITH ANY REFRIGERANTS ON THE "LIST OF PROHIBITED SUBSTANCES" FOR THAT SPECIFIC END-USE, IN ACCORDANCE WITH CALIFORNIA CODE OF REGULATIONS, TITLE 17, SECTION 95374. THIS DISCLOSURE STATEMENT HAS BEEN REVIEWED AND APPROVED BY HEATCRAFT REFRIGERATION PRODUCTS LLC AND HEATCRAFT REFRIGERATION PRODUCTS LLC ATTESTS, UNDER PENALTY OF PERJURY, THAT THESE STATEMENTS ARE TRUE AND ACCURATE.

## Technical Information

### Performance Data

Ambient Temperature (°F)	Saturated Suction Temperature (°F)	Capacity (BTU/H)	Altitude (ft)	AWEF Value
95	-10.0	27,650	0	3.15

### Electrical Data

Compressor(s)		Fan Motor(s)			Electric Ratings						
RLA	LRA	Quantity	Hp	FLA	Defrost Type	High or Low Amps?	Number of Contactors	MCA	MOPD	Evap. Fan Amps	Defrost Heater Amps
21.5	156	1	1/3	3.5	ELECTRIC DEFROST	NA		40.3	60	10	30

### Unit Specifications

Connections (in.)		Receiver 90% Full (lbs)		Fan Blade(s) Diameter (in)	Sound Data (dB)	Approx. Net Weight (lbs)
Liquid Line	Suction	Standard	Over Sized			
0.5	0.875	20.0	40.0	22	64	327

### Dimensional Drawing(s)

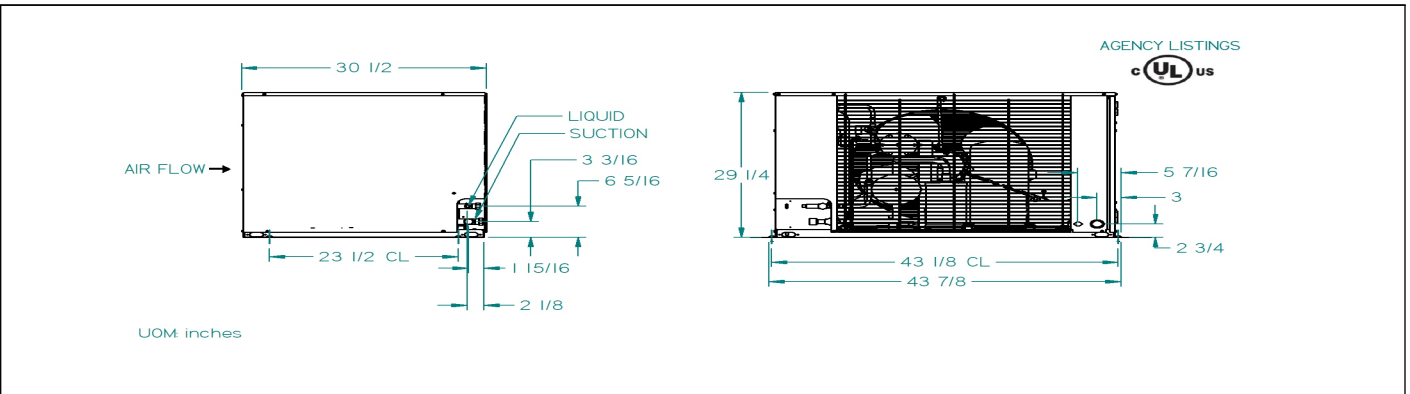

# LCH0060LCACZA0300 - SUBMITTAL



Project Name:		Project Location:	
Quote ID:		Item #:	1000
Submitted For:		Submitted On:	
Submitted By:		Submitted From:	
Identity #:		Tag:	

## Standard Features

### CABINET AND CONSTRUCTION

- MICROCHANNEL COIL TECHNOLOGY STANDARD ON ALL UNITS
- PAINTED STEEL CABINETS FOR SUPERIOR STRENGTH AND CORROSION PROTECTION
- HEAVY DUTY, STEEL, 1-1/2 TALL BASE

### SERVICEABILITY

- SUCTION SERVICE VALVES FOR HERMETIC AND SCROLL COMPRESSORS LOCATED OUTSIDE THE CABINET FOR QUICK INSTALLATIONS.
- RECEIVER WITH FUSIBLE PLUG, LIQUID SHUTOFF VALVE AND CHARGING PORT IS STANDARD
- LARGE ELECTRICAL PANEL FOR EASE OF ACCESS
- PREFABRICATED WIRING HARNESSES FOR TIGHT CRIMP CONNECTIONS AND CONSISTENT LABELING
- UNIT STAYS ON IF THE HOOD IS REMOVED FOR SERVICING
- SIGHT GLASS IS EASILY VIEWABLE

### QUALITY

- ALL UNITS ARE COMPLETELY LEAK TESTED IN A HELIUM ENVIRONMENT, BUMP TESTED AND ALLOWED TO CYCLE OFF ON THE HIGH AND LOW PRESSURE CONTROL. EACH UNIT HAS A COPY OF THE RUN DATA SHIPPED INSIDE THE ELECTRICAL PANEL
- ELECTRICAL CIRCUITS ARE COMPLETELY CHECKED FOR CONTINUITY
- PIPING IS LAID OUT TO MINIMIZE STRESS AND VIBRATION AND IS PRE-BENT TO ELIMINATE LEAKS
- ENCAPSULATED, AUTO-RESET, HIGH AND LOW PRESSURE CONTROLS TO ELIMINATE LEAKS (ADJUSTABLE LOW PRESSURE CONTROL STANDARD)

## Options

### Mounted Options

- |   |  |
|---|--|
| <ul style="list-style-type: none"> <li>Brand Label - LARKIN</li> <li>Motor - PSC</li> <li>Receiver Options - STANDARD</li> <li>Liquid Line Options - FILTER DRIER AND SIGHT GLASS</li> <li>Discharge Line Options - HEAD PRESSURE VALVE 100#</li> <li>Fused Disconnect - NO FUSED DISCONNECT</li> <li>Crankcase Heater - CRANKCASE HEATER</li> <li>Pre Charged - NONE</li> <li>Hail Guard Factory Installed - NONE</li> </ul> | <ul style="list-style-type: none"> <li>Brand Label from Table - N/A</li> <li>Coil Selection - MICROCHANNEL COIL</li> <li>Defrost Timer Options - ELECTRIC DEFROST TIMER AND CONTACTOR</li> <li>Suction Line Options - SUCTION TUBE ONLY</li> <li>Cabinet Selection - Painted</li> <li>Pressure Options - ADJUSTABLE LOW - FIXED HIGH</li> <li>Phase Loss Monitor - NONE</li> <li>Snow Legs - NONE</li> <li>ETO ID - N/A</li> </ul> |
|---|--|

## Minimum Unit Clearances

### Walls or Obstructions for Horizontal Air Flow

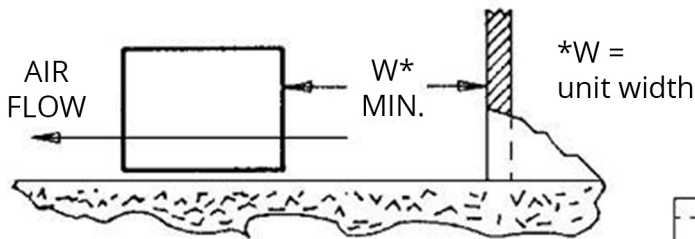

### Multiple Units with Horizontal Air Flow

